

VAL ADDA RES



CATÁLOGO' 2011
CATALOGUE | CATALOGUE





BÉLGICA | CHIPRE | CROÁCIA | DINAMARCA | ESLOVÉNIA |
 ESPANHA | FINLÂNDIA | FRANÇA | GRÉCIA | HOLANDA |
 INGLATERRA | IRLANDA | ISLÂNDIA | MONTENEGRO | NORUEGA
 | POLÓNIA | PORTUGAL | RUSSIA | SÉRVIA | UCRÂNIA
 CANADÁ | CHILE | CUBA | MÉXICO | SURINAME
 AUSTRÁLIA | JAPÃO | KOREIA | MACAU | SINGAPURA | TAIWAN
 ARÁBIA SAUDITA | BAHRAIN | EMIRATOS ÁRABES UNIDOS |
 KUWAIT | OMAN | QATAR
 ÁFRICA DO SUL | ANGOLA | ARGÉLIA | BENIM | CABO-VERDE
 | GUINÉ BISSAU | MARROCOS | MOÇAMBIQUE | NIGÉRIA | SÃO
 TOMÉ E PRÍNCIPE | SENEGAL | TUNÍSIA | MALI | TOGO

BELGIUM | CYPRUS | CROATIA | DENMARK | SLOVENIA | SPAIN
 | FINLAND | FRANCE | GREECE | THE NETHERLANDS | ENGLAND
 | IRELAND | ICELAND | MONTENEGRO | NORWAY | POLAND |
 PORTUGAL | RUSSIA | SERBIA | UKRAINE
 CANADA | CHILE | CUBA | MEXICO | SURINAME
 | AUSTRALIA | JAPAN | KOREA | MACAU | SINGAPORE | TAIWAN
 SAUDI ARABIA | BAHRAIN | UNITED ARAB EMIRATES | KUWAIT
 | OMAN | QATAR
 | SOUTH AFRICA | ANGOLA | ALGERIA | BENIN | CAPE VERDE |
 GUINEA BISSAU | MOROCCO | MOZAMBIQUE | NIGERIA | SAO
 TOME AND PRINCIPE | SENEGAL | TUNISIA | MALI | TOGO

BELGIQUE | CHYPRE | CROATIE | DANEMARK | SLOVÉNIE |
 SPAGNE | FINLANDE | FRANCE | GRÈCE | PAYS-BAS |
 ANGLETERRE | IRLANDE | ISELAND | MONTÉNÉGRO | NORVÈGE
 POLOGNE | PORTUGAL | RUSSIE | SERBIE | UKRAINE
 | CANADA | CHILI | CUBA | MEXIQUE | SURINAME
 | AUSTRALIE | JAPON | CORÉE | MACAO
 | BAHREÏN | ÉMIRATS ARABES UNIS | KUWEÏT | OMAN | QATAR
 | AFRIQUE DU SUD | ANGOLA | ALGÉRIA | BÉNIN | CAP-VERT |
 GUINÉE BISSAU | MOROC | MOZAMBIQUE | NIGÉRIA | SAO
 TOMÉ-ET-PRÍNCIPE | SENEGAL | TUNISIE | MALI | TOGO

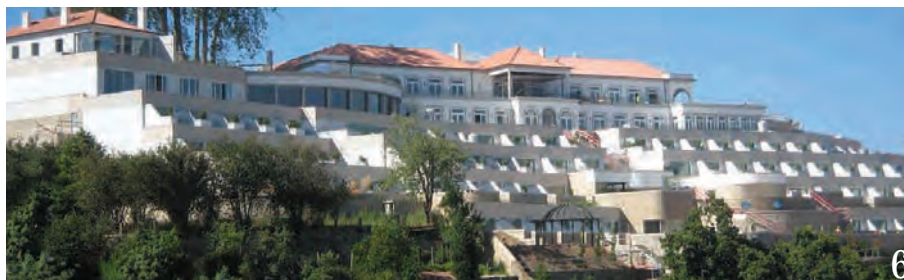

1- Jardins do Mondego, Coimbra
2- Hospital CUF, Porto
3- Hotel Dunas Spa, Albufeira
4- Dolce Vita Tejo, Lisboa

5- Aldar Sede Adubhadi, Dubai
6- Yeatman Hotel, V. N. de Gaia
7- Hotel do Martinhal, Sagres
8- HPP, Cascais

9- Fundação Champalimaud, Lisboa
10- Burj, Dubai



Fábrica Cerâmica de Valadares S.A. : A alma e o Saber

Em 2011 a Fábrica Cerâmica de Valadares S.A. completa 90 anos, integralmente dedicados à produção de artigos cerâmicos. A sua história está repleta de sucessos e de mudança ao longo dos anos, tendo passado pelo fabrico de artigos de Cerâmica estrutural, Revestimentos e Pavimentos e pelo Sanitário. Nos últimos 30 anos a Fábrica Cerâmica de Valadares S.A. dedicou-se exclusivamente ao Sanitário.

Uma empresa com tantos anos tem obrigatoriamente de ter uma “Alma” construída pela experiência e saber da Cerâmica, que toma “Corpo” na dedicação e competência dos seus Colaboradores e Parceiros.

Cada novo artigo é encarado como uma nova oportunidade de evoluir e surpreender.

O considerável investimento que a Fábrica Cerâmica de Valadares S. A. realiza na investigação de novas soluções técnicas e materiais é recompensado largamente com a noção de que está na linha da frente da produção de Sanitário, quanto a parâmetros de Qualidade, Design e Inovação nesta área de negócio muito exigente e competitiva.

De olhos sempre postos no futuro, a Fábrica Cerâmica de Valadares S.A. não hesitou em mudar uma e outra vez para se adaptar e até antecipar às mudanças no mercado. Hoje vende artigos Sanitários em cerca de 60 Países com especificações e necessidades diferentes, e cada novo cliente é encarado como um desafio de provar do que somos capazes.

É justa uma palavra para os nossos Fornecedores, que têm um papel fundamental na Qualidade do serviço que prestamos aos nossos clientes e que muito nos têm ajudado no desenvolvimento e comercialização de novos materiais e mercadorias. Aos nossos Clientes, resta-nos desejar que no nosso catálogo encontrem resposta às vossas necessidades e que vos possamos surpreender com a qualidade e originalidade da nossa oferta. O nosso compromisso é o de garantir que têm na Fábrica Cerâmica de Valadares S.A. uma Empresa inteiramente dedicada a corresponder às vossas melhores expectativas. Até breve.

The soul and knowledge.

In 2011 the Fabrica Ceramica Valadares, SA fullfill 90 years, fully dedicated to the production of ceramic pieces. Its history is replete with successes and change over the years, having gone through the manufacture of structural ceramics, tiles and Sanitaryware. Over the past 30 years the Fábrica Cerâmica de Valadares, SA devoted exclusively to Sanitaryware. A company with many years must have had a "soul" built by experience and knowledge of Ceramics, which makes "Body" the dedication and skill of its employees and partners.

Each new article is seen as a new opportunity to evolve and surprise.

The considerable investment that performs Fábrica Cerâmica de Valadares, SA in researching new materials and technical solutions is largely rewarded with the notion that he is in the forefront of production of Health, as the parameters of quality, design and innovation in this business too demanding and competitive.

Looking to the future, Fábrica Cerâmica de Valadares, SA not hesitate to change another time and another to adapt to and even anticipate market changes. Today sells Sanitaryware items in about 60 countries with different needs and specifications, and each new customer is seen as a challenge to prove what we can.

It's fair just a word for our suppliers, who have a key role in the quality of service we provide to our customers and which have greatly helped in the development and commercialization of new materials and goods.

To our clients, we can only hope that our catalogue is responding to your needs and that you can surprise with the quality and originality of our offer. Our commitment is to ensure that they have in Fábrica Cerâmica de Valadares, SA a company fully dedicated to meet your highest expectations.

See you soon.

L'âme et la connaissance

En 2011, la Fábrica Ceramica de Valadares, SA complète de 90 ans, entièrement dédié à la production de céramique. Son histoire est remplie de succès et les changements au fil des ans, après avoir traversé la fabrication de céramiques de construction, de revêtements et de sanitaire. Au cours des 30 dernières années, Fábrica Cerâmica de Valadares, SA consacré exclusivement au Sanitaire.

Une entreprise ayant de nombreuses années doivent avoir une «âme» construit par l'expérience et les connaissances de la céramique, ce qui rend "Corps" au dévouement et la compétence de ses employés et partenaires.

Chaque nouvel article est considéré comme une nouvelle opportunité d'évoluer et de surprise.

Les investissements considérables qui effectue Fábrica Cerâmica de Valadares, SA dans la recherche de nouveaux matériaux et des solutions techniques sont largement récompensés par la notion qu'il est à la pointe de la production du sanitaire, que les paramètres de qualité, de design et d'innovation dans ce secteur trop exigeant et compétitif.

Quant à l'avenir, Fábrica Cerâmica de Valadares, SA n'a pas hésite à changer une autre fois et une autre à s'adapter et même anticiper les évolutions du marché. Aujourd'hui Fábrica Cerâmica de Valadares, SA, vend des articles dans environ 60 pays qui ont des besoins différents et des spécifications, et chaque nouveau client est considéré comme un défi de prouver ce que nous pouvons.

C'est juste un mot pour nos fournisseurs, qui ont un rôle clé dans la qualité de service que nous offrons à nos clients et qui ont grandement contribué à l'élaboration et la commercialisation de nouveaux matériaux et des marchandises.

Pour nos clients, nous ne pouvons qu'espérer que, dans notre catalogue sont les réponses à vos besoins et que vous pouvez surprendre par la qualité et l'originalité de notre offre. Notre engagement est de veiller à ce qu'ils ont dans Fábrica Cerâmica de Valadares, SA une société entièrement dédiée pour répondre à vos attentes les plus élevées.

Vous voir bientôt.

LOUÇA SANITÁRIA | SANITARYWARE | PORCELAINE SANITAIRE

10 Egg | Egg Set | Egg

N 12 Egg Suspenso | Egg Wall Hung Set | Egg Suspendu

14 Assimétrica | Assimetrica Set | Assimetrica

16 Light | Light Set | Light

18 Nautilus | Nautilus Set | Nautilus

20 Nautilus Suspenso | Nautilus Wall Hung Set | Nautilus Suspendu

22 Oporto | Oporto Set | Oporto

24 Neoclássica | Neoclássica Set | Neoclássica

26 Tagus | Tagus Set | Tagus

N 28 Durius | Durius Set | Durius

30 Durius Suspenso | Durius Wall Hung Set | Durius Suspendu

32 Opus | Opus Set | Opus

34 Opus Suspenso | Opus Wall Hung Set | Opus Suspendu

36 Europa Plus | Europa Plus Set | Europa Plus

38 Europa Suspenso | Europa Wall Hung Set | Europa Suspendu

40 V-Junior | V-Junior | V-Junior

42 Infantil | Children Set | Infantile

44 Deficientes | Accessible toilets | Handicapé

N 46 Complementos Deficientes | Accessible Set Accessories | Compléments Handicape

N 49 Estruturas Sanitários Suspensos | Structure for Wall Hung | Support Pour Cuvette Suspendu

N 52 Urinóis | Urinals Set | Urinoirs

LAVATÓRIOS | WASHBASINS | LAVABOS

57 Sobre Móvel | Washbasin for furniture | Lavabos pour Meubles

63 Semi-Encastrar | Semi-Recessed | Semi-encastrer

63 Encastrar | Under Counter | Encastrer

N 65 Embutir | Vanety | Poser

N 70 Móveis | Furniture | Meubles

DIVERSOS | MISCELLANEOUS | MISCELLANEOUS

73 Lava-mãos | Hand Washbasin | Lave-Mains

74 Pias | Duty Sinks | Bac a laver

74 Bacia | BTW | BTW

74 Lava-roupas | Duty Sinks Fire Clay | Lave-Lange

BASES DE CHUVEIRO | SHOWER TRAYS | BACS À DOUCHE

N 76 Porcelana Angulares | Vitreous China Angle | Porcelaine Vitriifiée Angle

76 Porcelana Quadradas | Vitreous China Square | Porcelaine Vitriifiée Carré

77 Porcelana Rectangulares | Vitreous China Rectangular | Porcelaine Vitriifiée Rectangle

BASES DE CHUVEIRO | SHOWER TRAYS | BACS À DOUCHE (continuação | continuation | continuation)

81 Acrílicas Angulares | Angle Acrylique | Acrylique Angle

81 Acrílicas Quadradas | Square Acrylic | Acrylique Carré

BANHEIRAS | BATHTUBS | BAIGNOIRES

83 Sistemas de Hidromassagem | Hidromassage Systems | Système Hydromassage

84 Acrílicas Rectangulares | Rectangular Acrylic | Acrylique Rectangles

91 Painéis Rectangulares Laterais Acrílicos | Rectangular Front Panels for Bathtubs | Panneau Frontal Acrylique pour Baignoire

91 Painéis Rectangulares Topo Acrílicos | Rectangular Side Panels for Bathtubs | Panneau Latéral Acrylique pour Baignoire

91 Complementos Banheiras de Hidromassagem | Accessories for Whirlpool Bathtubs | Compléments pour Baignoire Hydromassage

92 Chapa Esmaltada | Enamelled Steel Bathtubs | Acier Émaille

94 Complementos Banheiras Esmaltadas | Accessories for Enamelled Steel Bathtubs | Compléments pour Baignoires Acier Émaille

TORNEIRAS | FAUCETS | ROBINETTERIE DE SALLE DE BAIN

N 95 If

96 Lusíada

97 Cayenne

98 Fidji

N 99 Assi (eco)

100 Lotto

101 Alicante

101 Valência

102 Fluxómetros e Torneiras Temporizadas | Flowmeters and timer taps | Fluxmètres et Robinetterie temposisateurs

104 Sistemas Electrónicos Fluxo | Electronic System Fluxo | Système Électronique Fluxo

104 Fluxómetros Fluxo | Flowmeters Fluxo | Fluxmètres Fluxo

COLUNAS/ RESGUARDOS | COLUMNS/ SHOWER TRAYS | COLONNES/ PANNEAU DOUCHE

N 105 Colunas | Columns | Colonnes

N 111 Resguardos | Shower Screens | Cabines

ACESSÓRIOS | ACCESSORIES | ACCESSOIRES

N 114 Duetto | Duetto Set | Duetto

115 Blend | Blend Set | Blend

116 Alfa | Alfa Set | Alfa

117 Neoclássica | Neoclássica Set | Neoclássica

118 Líder | Lider Set | Lider

118 Orion | Orion Set | Orion

COMPLEMENTOS | COMPLEMENTS | COMPLÉMENTS

119 Complementos | Complements | Compléments

TAMPOS EM CONTRAPLACADO DE MADEIRA LACADOS | SEAT & COVERS IN PLYWOOD PAINT FINISHED | ABATTANT EN BOIS LAQUÉ

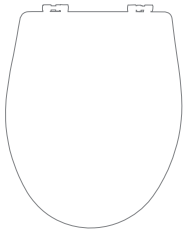

00
BRANCO
WHITE
BLANC

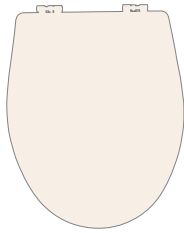

01
PÉROLA
PEARL
PERLE

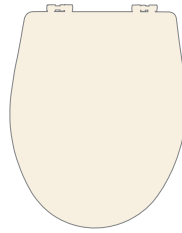

16
ALMOND
ALMOND
ALMOND

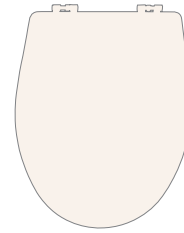

20
PERGAMON
PERGAMON
PERGAMON

TAMPOS EM CONTRAPLACADO MARÍTIMO EM TONS DE MADEIRA | SEAT & COVERS IN MARITIME WOOD | ABATTANT EN BOIS MARITIMÉ COULEURS BOIS



70
NATURAL
NATURAL
NATUREL



71
CEREJEIRA
CHERRY
CERISE



72
CASTANHO
CHESTNUT
CHÊNE



74
WENGUÉ
WENGUÉ
WENGUÉ

ESTRADOS EM CONTRAPLACADO MARÍTIMO EM TONS DE MADEIRA
WOODEN TRAYS IN MARITIME WOOD AND COLOUR CHART | PODIUM EN BOIS MARITIME COULEURS BOIS



ESTRADO GUADIANA
WOODEN TRAY GUADIANA
PODIUM GUADIANA



ESTRADO LIMA
WOODEN TRAY LIMA
PODIUM LIMA

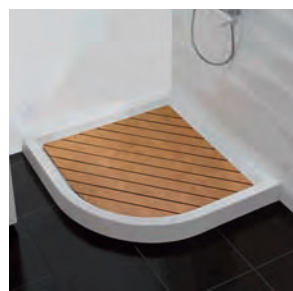

ESTRADO TREBBO
WOODEN TRAY TREBBO
PODIUM TREBBO



ESTRADO BERNINI
WOODEN TRAY BERNINI
PODIUM BERNINI



ESTRADO DUCCIO
WOODEN TRAY DUCCIO
PODIUM DUCCIO

	00 branco white blanc	01 pérola pearl perle	16 almond almond almond	20 pergamon pergamon pergamon	45 branco mate white matt blanc mat	98 bicolor bicolour bi-couleur	48 preto black noir
sanitários sanitary sanitaire							
egg	■						
N egg suspenso wall hung suspendu	■						
assimétrica	■						
light	■					■	■
nautilus	■						■
nautilus suspenso wall hung suspendu	■						■
oporto	■		■				■
neoclássica	■		■	■			■
tagus	■	■	■	■			
N durius	■						
durius suspenso wall hung suspendu	■						
opus	■						
opus suspenso wall hung suspendu	■						
europa plus	■	■		■			
europa suspenso wall hung suspendu	■			■			
v-júnior v-junior v-junior	■						
infantil children infantile	■						
N pmr accessible toilets handicapé	■						
N urinóis urinals urinoires	■						
N lavatórios de embutir vanity basins lavabos encastrer	■						
diversos miscellaneous miscellaneus	■	■	■	■			■
acessórios accessories accessoires							
N duetto					■		■
blend	■						■
alfa	■	■	■	■			
neoclássica	■		■				
líder	■	■	■	■			
orion	■		■	■			

■ a) Cores disponíveis | Available colours | Couleurs disponibles

■ b) Cores sujeitas a prazos de entrega especial e quantidade mínima | Colours subject to delivery time confirmation | Couleurs sujet delai livraison

Cores especiais e complementos em cores mate: sujeitas a negociação prévia, quanto a prazo, preço e quantidade mínima por encomenda. | Special colour and complements in matt colour are subject to previous agreement of quantities and prices. | Couleur spécial et compléments en couleur Matt: être assujetti à négociation delai livraison, prix et quantité minimum p/ commande.
Cor mate considerada em catálogo - 01 | Matt colour considered on colour chart - 01 | Couleur mate considéré sur catalogue - 01

CÓDIGOS DE COR SANITÁRIOS | COLOUR CHART SANITARY WARE | CODE COULEURS SANITAIRE

00	01	16	20	45	98	48
branco white blanc	pérola pearl perle	almond almond almond	pergamon pergamon pergamon	branco mate white matt blanc mat	bicolor bicolour bi-couleur	preto black noir

CORES ESPECIAIS | SPECIAL COLOURS | COULEURS SPÉCIALES

03	33	35	48
tangerina orange mandarine	cereja red cerise	alface green vert	preto black noir

SÍMBOLOS/ LEGENDA | SYMBOL/ LETTERING | SYMBOLE/ LÈGENDE

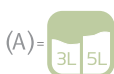

(A) =
bacia com dupla descarga (3Lts / 5Lts)
wc dual flush (3Lts / 5Lts)
wc double décharge (3Lts / 5Lts)

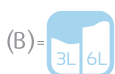

(B) =
bacia com dupla descarga (3Lts / 6Lts)
wc dual flush (3Lts / 6Lts)
wc double décharge (3Lts / 6Lts)



(C) =
comprimento da bacia (60cm)
wc width (60cm)
wc longueur (60cm)



Certificação hídrica de autoclismo
Certification hydric of water flush
Certification hydrique de chasse d'eau

PORCELAINE SANITAIRE | SANITARYWARE | LOUÇASANITÁRIA





Design: Gracinha Viterbo Arq. de Interiores - Atelier Graça Viterbo

EGG

SÉRIE | SET | SERIE

CORES DISPONÍVEIS
available colors | couleurs disponibles

00 - branco | white | blanc



(1) Definir ligação ao chão ou a parede conforme pretendido
Available vertical or horizontal outlet | Disponible avec sortie horizontal | sortie vertical
* Inclui parafusos de fixação | With fixing screws | Avec vis de fixation



Valadares

39357XX2 Lavatório pousar | Washbasin | Lavabo (50 x 38 cm)



39411002 Bacia sífônica par/ch | BTW | WC Simple



394111XX2 Bidé | Bidet | bidet



39881XX2 * Lavatório | Washbasin | Lavabo (91 x 52 cm)



390071XX2 * Bacia compacta | WC | WC (1)

50264004 Tampo termodur | Seat & cover | Abattant

50264005 Tampo termodur p/ bacia c/ dobradiça soft-close | Seat & cover soft close | Abattant soft-close





Design: Gracinha Viterbo Arq. de Interiores - Atelier Graça Viterbo

E G G SUSPENSO

WALL HUNG | SUSPENDU
SÉRIE | SET | SERIE

CORES DISPONÍVEIS
available colors | couleurs disponibles

00 - branco | white | blanc



(1) Definir ligação ao chão ou a parede conforme pretendido
Available vertical or horizontal outlet | Disponible avec sortie horizontal | sortie vertical
* Inclui parafusos de fixação | With fixing screws | Avec vis de fixation

39871 Lavatório suspenso com coluna integrada (34 x 66 cm)
Washbasin Wall Hung | Lavabo Suspendu



39357XX2 Lavatório pousar | Washbasin | Lavabo (50 x 38 cm)



39401 Bidé suspenso | Bidet wall hung | Bidet suspendu



39001 Bacia suspensa | WC wall hung | WC Suspendu





Design: Filipe Oliveira Dias, Arq.

ASSIMÉTRICA

SÉRIE | SET | SERIE

CORES DISPONÍVEIS
available colors | couleurs disponibles

00 - branco | white | blanc



(1) Definir ligação ao chão ou a parede conforme pretendido
Available vertical or horizontal outlet | Disponible avec sortie horizontal | sortie vertical
* Inclui parafusos de fixação | With fixing screws | Avec vis de fixation

- 32331002 * Lavatório | Washbasin | Lavabo (51 x 58 cm)
- 32351002 Lavatório pousar | Washbasin | Lavabo (51 x 58 cm)
- 32220002 * Meia coluna suspensa | Half pedestal | Demi-Colonne



32411002 * Bidé | Bidet | Bidet



32051002 * Bacia compacta Par/Ch (1) | WC bowl concealed outlet/ horizontal outlet - vertical outlet | WC c/c S/V - S/H





Design: Luís Rebelo de Andrade, Arq. | HRB Designers

LIGHT

SÉRIE | SET | SERIE

CORES DISPONÍVEIS
available colors | couleurs disponibles

00 - branco | white | blanc



98 - bicolor
bicolour | bi-couleur



48 - preto
black | noir



* Inclui parafusos de fixação | With fixing screws | Avec vis de fixation



Valadares

36331XX2 *Lavatório médio | Washbasin medium
Lavabo moyen (55 x 45 cm)



36401XX2 Bidé suspenso | Bidet wallhung
Bide Suspendu



36001XX2 Bacia suspensa | Wall hung wc
WC Suspendu





Design: HRB Designers

NAUTILUS

SÉRIE | SET | SERIE

CORES DISPONÍVEIS

available colors | couleurs disponibles

00 - branco | white | blanc



48 - preto
black | noir



(1) Definir ligação ao chão ou a parede conforme pretendido
Available vertical or horizontal outlet | Disponible avec sortie horizontal | sortie vertical
* Inclui parafusos de fixação | With fixing screws | Avec vis de fixation

- 34331XX2 *Lavatório | Washbasin | Lavabo (51x51cm)
- 34200XX2 Coluna | Pedestal | Colonne
- 34220XX2 Coluna suspensa | Half pedestal | Demi-Colonne



34411XX2 *Bidé | Bidet | Bidet



34051XX2 *Bacia compacta Par/ Ch (1)
WC horizontal or vertical outlet | WC c/c S/V - S/H





Design: HRB Designers

NAUTILUS SUSPENSO

WALL HUNG | SUSPENDU

SÉRIE | SET | SERIE

CORES DISPONÍVEIS

available colors | couleurs disponibles

00 - branco | white | blanc



48 - preto
black | noir



* Inclui parafusos de fixação | With fixing screws | Avec vis de fixation

34331XX2 * Lavatório | Washbasin | Lavabo (51 x 51 cm)
34220XX2 Coluna suspensa | Half pedestal | Demi-Colonne



34401XX2 Bidé suspenso | Bidet wall hung | Bidet suspendu



34001XX2 Bacia suspensa | WC wall hung | WC Suspendu





OPORTO

SÉRIE | SET | SERIE

CORES DISPONÍVEIS

available colors | couleurs disponibles

00 - branco | white | blanc



16 - Almond
Almond | Almond



20 - Pergamon
Pergamon | Pergamon



(1) Definir ligação ao chão ou a parede conforme pretendido
Available vertical or horizontal outlet | Disponible avec sortie horizontal | sortie vertical
* Inclui parafusos de fixação | With fixing screws | Avec vis de fixation

- 30331XX2 * Lavatório | Washbasin | Lavabo (64,5 x 54 cm)
- 30200XX2 Coluna | Pedestal | Colonne
- 30220XX2 Meia coluna suspensa | Half pedestal | Demi-Colonne

OPORTO

SÉRIE | SET | SERIE



30411XX2 * Bidé | Bidet | Bidet



30051XX2 * Bacia compacta Par/Ch (1) | WC bowl close washdown concealed outlet/vertical/horizontal outlet | WC c/c S/V - S/H





neoclássica

SÉRIE | SET | SERIE

CORES DISPONÍVEIS
available colors | couleurs disponibles

00 - branco | white | blanc



16- Almond
Almond | Almond



48- Preto | Black | Noir



(1) Definir ligação ao chão ou à parede conforme pretendido
Available vertical or horizontal outlet | Disponible avec sortie horizontal/ sortie vertical
(2) É fornecido com 2 furos | Supplied with 2Th | Fourni avec 2T
* Inclui parafusos de fixação | With fixing screws | Avec vis de fixation

- 16321XX2 * Lavatório normal | Washbasin | Lavabo (67 x 50 cm)(1)
- 16331XX2 * Lavatório médio | Washbasin medium | Lavabo moyen (61 x 50 cm)(1)
- 16351XX2 Lavatório médio c/espaldar | Washbasin medium with back splash | Lavabo moyen avec épaulière (61 x 50 cm) (1)
- 16369XX2 Lava-mãos c/espaldar | Hand washbasin with back splash | Lave-main avec épaulière (49 x 33 cm)(2)
- 16200XX2 Coluna | Pedestal | Colonne



16411XX2 * Bidé | Bidet | Bidet



- 16024XX2 * Bacia compacta desc. chão | WC bowl close washdown concealed outlet floor | WC c/c Sortie Vertical(1)
- 16021XX2 * Bacia compacta desc. parede | WC bowl close coupled washdown concealed horizontal outlet WC c/c Sortie Horizontal (1)
- 16014XX2 * Bacia normal desc. chão | WC concealed "S" trap (low level pan vertical outlet) | WC simple sortie Vertical (1)
- 16011XX2 * Bacia normal desc. parede | WC concealed "P" trap (low level pan horizontal outlet) | WC simple sortie horizontal (1)





TAGUS

SÉRIE | SET | SERIE

CORES DISPONÍVEIS
available colors | couleurs disponibles

00 - branco
white
blanc



01- Pérola
Pearl
Perle



16- Almond
Almond
Almond



20- Pergamon
Pergamon
Pergamon



(1) Definir ligação ao chão ou a parede conforme pretendido
Available vertical or horizontal outlet | Disponible avec sortie horizontal | sortie vertical
* Inclui parafusos de fixação | With fixing screws | Avec vis de fixation



Valadares

TAGUS

SÉRIE | SET | SERIE

31331 * Lavatório | Washbasin | Lavabo (62 X 47 cm)

31200 Coluna | Pedestal | Colonne



31411 * Bidé | Bidet | Bidet



31051 Bacia compacta Par/Ch (1) | WC bowl close washdown concealed outlet/ horizontal outlet | WC c/c sortie vertical/ sortie horizontal





DURIUS

SÉRIE | SET | SERIE

CORES DISPONÍVEIS
available colors | couleurs disponibles

00 - branco | white | blanc



(1) Definir ligação ao chão ou a parede conforme pretendido
Available vertical or horizontal outlet | Disponible avec sortie horizontal | sortie vertical
* Inclui parafusos de fixação | With fixing screws | Avec vis de fixation

38411002* Bidé | Bidet | Bidet



38041002 Bacia "Back to Wall" | WC "Back to Wall" | WC "Back to



38052002 Bacia Compacta "Back to Wall" | WC bowl close "Back to Wall" | WC "Back to Wall"



38051002 Bacia Compacta Par/Ch. | Wc bowl close washdown conceale outlet
 | Wc C/C sortie vertical/horizontal (1)





DURIUS SUSPENSO

WALL HUNG | SUSPENDU

SÉRIE | SET | SERIE

CORES DISPONÍVEIS

available colors | couleurs disponibles

00 - branco | white | blanc



(1) Definir ligação ao chão ou a parede conforme pretendido
Available vertical or horizontal outlet | Disponible avec sortie horizontal | sortie vertical
* Inclui parafusos de fixação | With fixing screws | Avec vis de fixation

- 38321 * Lavatório Normal 1 F. | Washbasin Normal 1 F. | Lavabo Normal 1 F. (60 x 48 cm)
- 38331 * Lavatório Médio 1 F. | Washbasin Medium 1 F. | Lavatório Moyen 1 F. (55,5 x 45 cm)
- 39311 * Lavatório Junior | Washbasin Junior | Lavabo Junior (45 x 37 cm)
- 38220 Coluna suspensa | Half Pedestal | Demi-Colonne

DURIUS SUSPENSO

WALL HUNG | SUSPENDU

SÉRIE | SET | SERIE



38001 Bacia suspensa | Wall hung WC | WC suspendu



38401 Bidé suspenso | Wall hung Bidet | Bidet suspendu





OPUS

SÉRIE | SET | SERIE

CORES DISPONÍVEIS
available colors | couleurs disponibles

00 - branco | white | blanc



(1) Definir ligação ao chão ou à parede conforme pretendido | Available vertical or horizontal outlet | Disponible avec sortie horizontal/sortie vertical
(2) Este lavatório tem a possibilidade de ser instalado com coluna ou pousado | This washbasin has a chance to be fitted with pedestal or flat | Ce lavabo a la possibilité pour être installé avec collone ou plat

* Inclui parafusos de fixação | With fixing screws | Avec vis de fixation

- 37331002 * Lavatório médio | Washbasin medium | Lavabo moyen (60 x 48 cm) (1) (2)
- 37311002 * Lavatório júnior | Washbasin junior | Lavabo junior (55 x 45 cm) (2)
- 13200002 Coluna | Pedestal | Colonne
- 13220002 Coluna Suspensa | Half-Pedestal | Demmi-Colonne



37411002 * Bidé | Bidet | Bidet



37051002 * Bacia compacta Par/ Ch | WC horizontal or vertical outlet C c/c S/V - S/H (1)





OPUS SUSPENSO

wall hung | suspendu

SÉRIE | SET | SERIE

CORES DISPONÍVEIS

available colors | couleurs disponibles

00 - branco | white | blanc



(1) Definir ligação ao chão ou à parede conforme pretendido | Available vertical or horizontal outlet | Disponible avec sortie horizontal/sortie vertical
(2) Este lavatório tem a possibilidade de ser instalado com coluna ou pousado | This washbasin has a chance to be fitted with pedestal or flat | Ce lavabo a la possibilité pour être installé avec collone ou plat

* Inclui parafusos de fixação | With fixing screws | Avec vis de fixation



Valadares

37331002 * Lavatório médio | Washbasin medium | Lavabo moyen (60 x 48 cm) (1) (2)

37311002 * Lavatório júnior | Washbasin junior | Lavabo junior (55 x 45 cm) (2)

13220002 Coluna suspensa | Half pedestal | Demi-colonne

OPUS SUSPENSO

wall hung | suspendu

SÉRIE | SET | SERIE



37401002 Bidé | Bidet | Bidet



37001002 Bacia | WC wall hung | WC suspendu





EUROPA PLUS

SÉRIE | SET | SERIE

CORES DISPONÍVEIS

available colors | couleurs disponibles

00 - branco | white | blanc



01 - Pérola
Pearl
Perle



20- Pergamon
Pergamon
Pergamon



* Inclui parafusos de fixação | With fixing screws | Avec vis de fixation

** Limitado ao stock existente | Limited to available stock | Limité stock existant

Nota: Série limitada ao stock existente | P.S: Limited to available stock | P.S: Limité stock existant



33013XX2 * Bacia normal desc. chão | WC concealed "S" trap | WC Simple Sortie Vertical
12011XX2 * Bacia normal desc. parede | WC concealed "P" trap | Wc Simple Sortie Horizontal



12321XX2 * Lavatório normal | Washbasin normal | Lavabo normale (67 x 53 cm)
12331XX2 * Lavatório médio | Washbasin medium | Lavabo moyen (61 x 49 cm)
12311XX2 * Lavatório júnior | Washbasin junior with no pedestal | Lavabo júnior (58 x 44 cm) (1)
12361XX2 * Lava-mãos (não admite coluna) | Hand washbasin | Lave-Main (S/ colonne) (45 x 34 cm)
13200XX2 Coluna | Pedestal | Colonne
12220XX2 Coluna suspensa (p/ lavatório normal e médio) | Half pedestal (for medium and normal washbasin) | Demi-Colonne suspendu (p/ lavabo Normale et Moyen)
12240XX2 Coluna suspensa (p/ lavatório júnior) | Half pedestal (only for junior washbasin) | Demi-Colonne Suspendu (p/ Lavabo júnior)



12011XX2 * Bidé | Bidet | Bidet



33023XX2 * Bacia compacta desc. chão | WC bowl close washbasin concealed outlet floor | WC c/c Sortie Vertical
33021XX2 * Bacia compacta desc. parede | WC bowl close coupled washdown horizontal outlet | WC c/c Sortie Horizontal





EUROPA SUSPENSO

wall hung | suspendu

SÉRIE | SET | SERIE

CORES DISPONÍVEIS

available colors | couleurs disponibles

00 - branco | white | blanc



20 - Pergamon | Pergamon | Pergamon



* Inclui parafusos de fixação | With fixing screws | Avec vis de fixation

- 12321XX2 * Lavatório normal | Washbasin normal | Lavabo normal (67 x 53 cm)
- 12331XX2 * Lavatório médio | Washbasin medium | Lavabo moyen (61 x 49 cm)
- 12311XX2 * Lavatório júnior | Washbasin junior | Lavabo júnior (58 x 44 cm) (1)
- 12220XX2 Coluna suspensa (p/ lavatório normal e médio) | Half pedestal (for medium and normal washbasin) | Demi-Colonne (p/ Lavabo Normale et Moyen)
- 12240XX2 Coluna suspensa (p/ lavatório júnior) | Half pedestal (only for junior washbasin) | Demi-Colonne (p/ Lavabo Junior)

EUROPA SUSPENSO

wall hung | suspendu

SÉRIE | SET | SERIE



18401XX2 Bidé suspenso | Wall hung bidet | Bidet Suspendu



18001XX2 Bacia suspensa | Wall hung WC | WC Suspendu





v-junior

SÉRIE | SET | SERIE

CORES DISPONÍVEIS
available colors | couleurs disponibles

00 - branco | white | blanc



* Inclui parafusos de fixação | With fixing screws | Avec vis de fixation

18601 * Lavatório | Washbasin | Lavabo



18651 * Bacia normal Par/Ch. | WC vertical or horizontal outlet | WC sortie vertical/horizontal



551118100
Tanque descarga 4L
Wall mounted Cistern
Reservoir de encastrer

55034181
Placa de comando cromada
Flush panel plated
Plaqué possouir chromé

50603032
Fluxómetro de embutir p/ sanita Fluxo*
Flowmeter wc*
Fluxmètre wc*





infantil

SÉRIE | SET | SERIE

CORES DISPONÍVEIS
available colors | couleurs disponibles

00 - branco | white | blanc



* Inclui parafusos de fixação | With fixing screws | Avec vis de fixation

infantil

SÉRIE | SET | SERIE

16371002 * Lavatório normal | Washbasin normal | Lavabo normale (40 x 32 cm)
 16230002 Coluna | Pedestal | Colonne



55118100
 Tanque descarga 4L
 Wall mounted Cistern
 Reservoir de encastrer
 55034181
 Placa de comando cromada
 Flush panel plated
 Plaqué possouir chromé



55118000
 Tanque Plástico N4
 Plastic Cistern N4
 Reservoir Plastique N4



12131002
 Tanque alto universal
 Universal Cistern
 Reservoir Universale



50603032
 Fluxómetro de sanita exterior
 Flowmeter wc
 Fluxmètre wc

18650002 * Bacia normal descarga chão c/ emboque de borracha
 WC "S" trap with rubber gasket | WC Simple sortie vertical avec gomme





GRESANIT® * WC p/ pessoas com mobilidade reduzida

pmr*

accessibles toilets | handicapé

SÉRIE | SET | SERIE

CORES DISPONÍVEIS
available colors | couleurs disponibles

00 - branco | white | blanc



* Inclui parafusos de fixação | With fixing screws | Avec vis de fixation

Nota: De acordo com o Decreto-Lei nº 163/2006, secção 2.9



- 78791002 *Lavatório | Washbasin | Lavabo
- 55025000 Suporte basculante p/ lavabo em aço inox escovado | Lift support in stainless steel for washbasin
- 55089000 Barre basculant d'acier inox pour lavabo | Suporte fixo em aço inox c/ pré-regulação | Fixed support for washbasin with pre adjust | Barre d'acier avec pre-ajustage

18003002 Bacia suspensa | Wall hung WC | WC suspendu



GRESANIT®

78639002 Base de chuveiro Aqua 90 x 90cm | Shower Tray Aqua 90 x 90cm
Receveur Douche Aqua 90 x 90cm

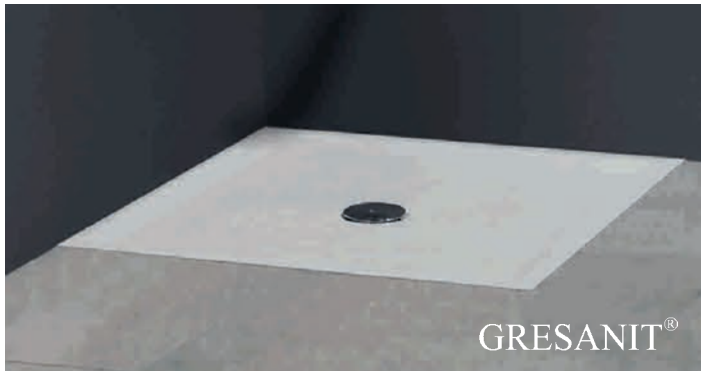

GRESANIT®

18063002 Bacia normal Par/Ch. | WC vertical or horizontal outlet | WC sortie vertical/horizontal



55118110
Tanque encastrável DD
Wall mounted Cistern
Reservoir de encastrer



55118000
Tanque Plástico N4
Plastic Cistern N4
Reservoir Plastique N4



50603032
Fluxómetro de sanita exterior
Flowmeter wc | Fluxmètre wc



12131002
Tanque alto universal
Universal Cistern
Reservoir Universale

50603032
Fluxómetro de embutir p/ sanita Fluxo*
Flowmeter wc* | Fluxmètre wc*



- 50663022 Monocomando **Style** para lavatório | Single lever **Style** for washbasin | Mitigeur **Style** pour lavabo (1)
 50663032 Monocomando **Style** para banheira | Single lever **Style** for bathtubs | Mitigeur **Style** pour baignoire (2)
 50663042 Monocomando **Style** para base de chuveiro | Single lever **Style** for shower tray | Mitigeur **Style** pour bac à douche (3)



- 50663000 Monocomando para lavatório | Single lever faucet for washbasin | Mitigeur pour lavabo (4)
 50680012 Misturadora c/ chuveiro de válvula | High pressure mixer and shower with valve | Mitigeur avec douchete (5)
 50680022 Misturadora de base de chuveiro | High pressure mixer for shower tray Mitigeur douche



- 50989020 Espelho basculante | Mirror | Miroir D'inclinaison réglable (60 x 76 cm)
 50989010 Espelho basculante | Mirror | Miroir D'inclinaison réglable (41 x 76 cm) (6)





55140040 Apoio aço inox 300mm
Support with 300mm | Barre simple 300mm
55140050 Apoio aço inox 500mm
Support with 500mm | Barre simple 500mm
55140060 Apoio aço inox 800mm
Support with 800mm | Barre simple 800mm
NOTA: Tubo Ø 35mm | Pipe Ø 35mm | Tube Ø 35mm

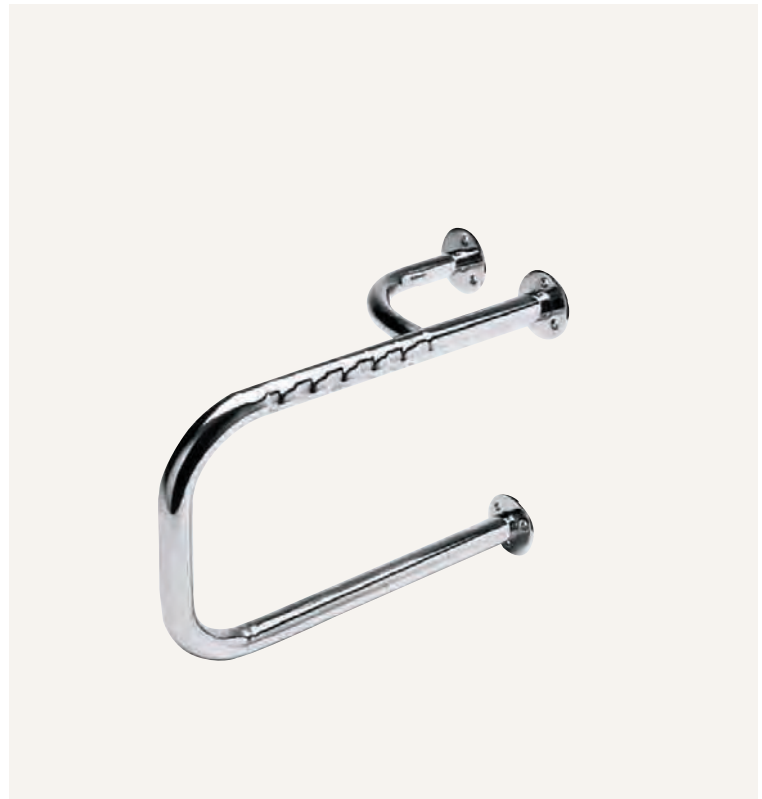

55140070 Apoio de lavatório direito
Washbasin support right | Barre lavabo droite
55140080 Apoio de lavatório esquerdo
Washbasin support left | Barre lavabo gauche
NOTA: Tubo Ø 35mm | Pipe Ø 35mm | Tube Ø 35mm

55140090 Apoio de sanita direito
WC support right | Barre WC droite
55140100 Apoio de sanita esquerdo
WC support left | Barre WC gauche
NOTA: Tubo Ø 35mm | Pipe Ø 35mm | Tube Ø 35mm



ACCESSIBLE SET ACCESSORIES
COMPLÉMENTS HANDICAPÉ



55140120 Apoio de sanita basculante direito c/ porta-roló
Adjustable support for WC right with paper holder
Réglable pour WC droite avec support de papier

55140130 Apoio de sanita basculante esquerdo c/ porta-roló
Adjustable support for WC left with paper holder
Barre réglable pour WC gauche avec support de papier

NOTA: Tubo Ø 35mm | Pipe Ø 35mm | Tube Ø 35mm



55140140 Apoio de sanita basculante c/ porta-roló
Adjustable support for WC with paper holder
Barre de support WC avec support de papier

NOTA: Tubo Ø 35mm | Pipe Ø 35mm | Tube Ø 35mm



55140110 Apoio de sanita articulado
Articulated WC support
Barre de support articulé pour WC

NOTA: Tubo Ø 35mm | Pipe Ø 35mm | Tube Ø 35mm



55059000 Banco para chuveiro 400mm
Shower seat 400mm | Siège p/ douche 400mm

55192000 Banco para chuveiro 700mm
Shower seat 700mm | Siège p/ douche 700mm

NOTA: Tubo Ø 35mm | Pipe Ø 35mm | Tube Ø 35mm



N



55037074 | Estrutura para bacia suspensa, dupla descarga 350 mm
| Wall mounted cistern, dual flush for wc wall hung
(350 mm) | Support métallique pour wc suspendu
double pulsoir (350 mm)

- 55034191 Placa de comando **Plat 1** redonda (cromada) (1)
- 55034193 Placa de comando **Plat 1** (branca)
- 55034194 Placa de comando **Plat 1** (cromo-mate)
- 55034201 Placa de comando **Plat 2** rectangular (cromada) (2)
- 55034204 Placa de comando **Plat 2** (cromo-mate)



55117010 | Estrutura metálica encastrar dupla pré-montada, p/ bacia suspensa c/ mecanismo de dupla
descarga, curvas de esgoto e acessórios de fixação. | Structure for wall mounting WC no cistern,
with outlet pipe, fixing accessories and without front panel | Support Métallique P/cuvette
suspendu avec réservoir, mécanisme 3/6 LT et accessoires

55117000 | Estrutura metálica encastrar dupla pré-montada, p/ bacia suspensa c/ mecanismo, curvas de
esgoto e acessórios de fixação. | Double structure for wall mountig WC with cistern, outlet pipe
and fixing accessories, without front panel | Support Métallique Double p/cuvette suspendu,
Mécanisme 3/6 LT et accessoires

ESTRUTURAS PARA SANTÁRIOS SUSPENSOS

STRUCTURE FOR WALL HUNG
SUPPORT MÉTALLIQUE P/ CUVETTE SUSPENDU



55035001 | Estrutura metálica p/ lavatório suspenso c/ curva de esgoto e acessórios de fixação
| Metallic structure for wall mounting washbasin with outlet pipe and fixing accessories
| Support Métallique pour cuvette suspendu avec accessoires fixation



55036001 Estrutura metálica encastrar pré-montada p/ bacia suspensa s/ tanque c/ curva de esgoto e acessórios de fixação
Wall mounted structure for wall hung wc, with no cistern, with trap and fixing accessories.
Support Métalique p/cuvette suspendu, Mécanisme 3/6 LT et accessoires fixation



55046041 Estrutura para bidé suspenso (400 mm)
Wall mounted structure for bidet wall hung
Support pour bidet

NOTA: Estrutura compatível só com os bidés Light e Nautilus
Structure only for bidet Light and Nautilus
Support Métalique compatible seule Bidet Light et Nautilus



55046001 Estrutura metálica de encastrar pré-montada p/ bidé suspenso c/ curva de esgoto e acessórios de fixação
Wall mounted structure for wall hung wc, with trap and fixing accessories | Support Métalique P/Cuvette suspendu avec accessoires fixation.

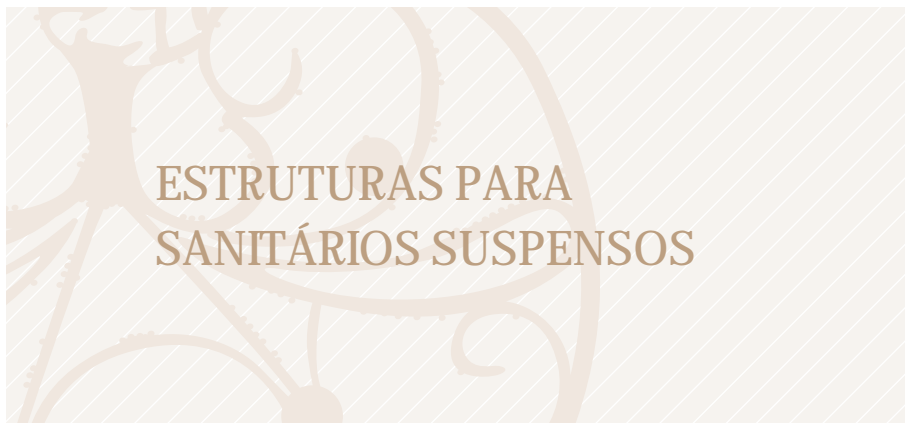

ESTRUTURAS PARA
SANITÁRIOS SUSPENSOS



55136001 | Estrutura metálica dupla encastrar pré-montada p/ 2 bidés suspensos c/ curva de esgoto e acessórios de fixação. | Wall mounted structure for wall hung wc, with no cistern, with trap and fixing accessories. Support Métalique double encastrer pour 2 bidét suspendu avec accessoires fixation.



50603010 | Estrutura de instalação para urinol com fluxómetro FLUXO
Structure for urinal with flowmeter Fluxo
Support pour urinoir avec fluxomètre Fluxo
55154040 | Conj. Acessórios p/ estrutura de fluxómetro FLUXO
Set accessories for wc wall hung with flowmeter | Accessoires pour wc suspendu avec fluxomètre

STRUCTURE FOR WALL HUNG
SUPPORT MÉTALLIQUE P/ CUVETTE SUSPENDU



URINÓIS

| urinals | urinoirs

SÉRIE | SET | SERIE

CORES DISPONÍVEIS
available colors | couleurs disponibles

00 - branco | white | blanc



* Inclui parafusos de fixação | With fixing screws | Avec vis de fixation

78530002 Urinol Kino | Urinal Kino | Urinoir Kino



39530002 Urinol EGG (34 x 66 cm) | Urinal EGG (34 x 66 cm) | Urinoir EGG (34 x 66 cm)



Design: Gracinha Viterbo Arq. de Interiores - Atelier Graça Viterbo

18570002 Urinol s/ água Hello | Urinal waterless Hello | Urinoir sans eau Hello



A pensar no futuro sustentado do Planeta e no facto de:
 Cerca de 97% das reservas de água do mundo serem salgadas
 Uma em cada 8 pessoas não tem acesso a água potável
 Todos os anos 1,8 milhões de pessoas morrem devido ao consumo de água imprópria
 São necessários 1.350 litros de água para se produzir 1 Kg de trigo
 Na Europa Ocidental cada pessoa gasta por dia cerca de 40 litros de água em descargas sanitárias
 Um urinol, em média, consome cerca de 80 000 a 120 000 litros de água por ano!!!
 a Valadares apresenta o URINOL HELLO, preparado para receber um sistema de desinfecção sem água da Espace Écologie. Esta tecnologia permite:

- eliminar o consumo de água,
- erradicar maus cheiros,
- eliminar calcário da superfície vidrada
- evita o entupimento das tubagens
- simplifica a manutenção quotidiana

O sistema é de fácil aplicação e substituição. A sua montagem é feita no furo de esgoto do urinol com a recarga (Ogiva) posicionada na parte superior. É fornecida uma chave para uma fácil substituição.
 A substituição da recarga é feita trimestralmente em situações de grandes utilizações (Centros Comerciais, Estações de Serviço...) e semestralmente em situações de utilização média (Escolas, Cafés...).
 Na limpeza diária é suficiente a passagem de uma esponja humedecida com um detergente neutro.
 Se considerarmos um urinol com uma taxa de utilização média (250 descargas de 2 litros) o consumo diário será de 0.5 m³ de água. Sendo o custo aproximado de 4€/ m³ a factura anual será de 700€.
 Em alternativa, os custos associados ao Urinol HELLO e respectivo sistema desodorizante encontram-se exemplificados na tabela abaixo:

	Custo Inicial	Recargas Anuais	Custo Anual	Factura anual água por urinol	Poupança anual por urinol
1º Ano	415€	180€	595€	700€	105€
2º Ano e seguintes	-	240€	240€	700€	460€



URINÓIS

| urinals | urinoirs

SÉRIE | SET | SERIE

CORES DISPONÍVEIS
available colors | couleurs disponibles

00 - branco | white | blanc



* Inclui parafusos de fixação | With fixing screws | Avec vis de fixation

78924002 Separador cerâmico p/ urinol | Ceramic separator for urinal. Fixation in stainless steel | Séparateur urinoir en ceramique fixation acier



78560002 URI-VAL urinol com ralo cerâmico
URI-VAL urinal with ceramic strainer | URI-VAL urinoir avec crépine



Design: Filipe Oliveira Dias Arq.

18510002 Urinol Flórida com ralo cerâmico | Urinal Flórida with ceramic strainer | Urinoir Flórida avec crépine

18511002 Urinol Flórida com ralo cerâmico (entrada de água p/ trás) | Urinal Flórida with ceramic strainer (back water inlet) | Urinoir Flórida avec accès eau par derrière



18520002 Urinol Niagara | Urinal Niagara | Urinoir Niagara | Urinol Niagara (entrada de água p/ trás)
18521002 Urinal Niagara (back water inlet) | Urinoir Niagara (accès eau par derrière)



18540002 Urinol Face 2 | Urinal Face 2 | Urinoir Face 2



18541002 Urinol Face 2 (entrada de água p/ trás) | Urinal Face 2 (back water inlet) | Urinoir Face 2 (accès eau par derrière)



18550002 Urinol de canto | Corner Urinal | Urinoir Angle

URINÓIS | urinals | urinoirs

LAVABOS | WASHBASINS | LAVATÓRIOS

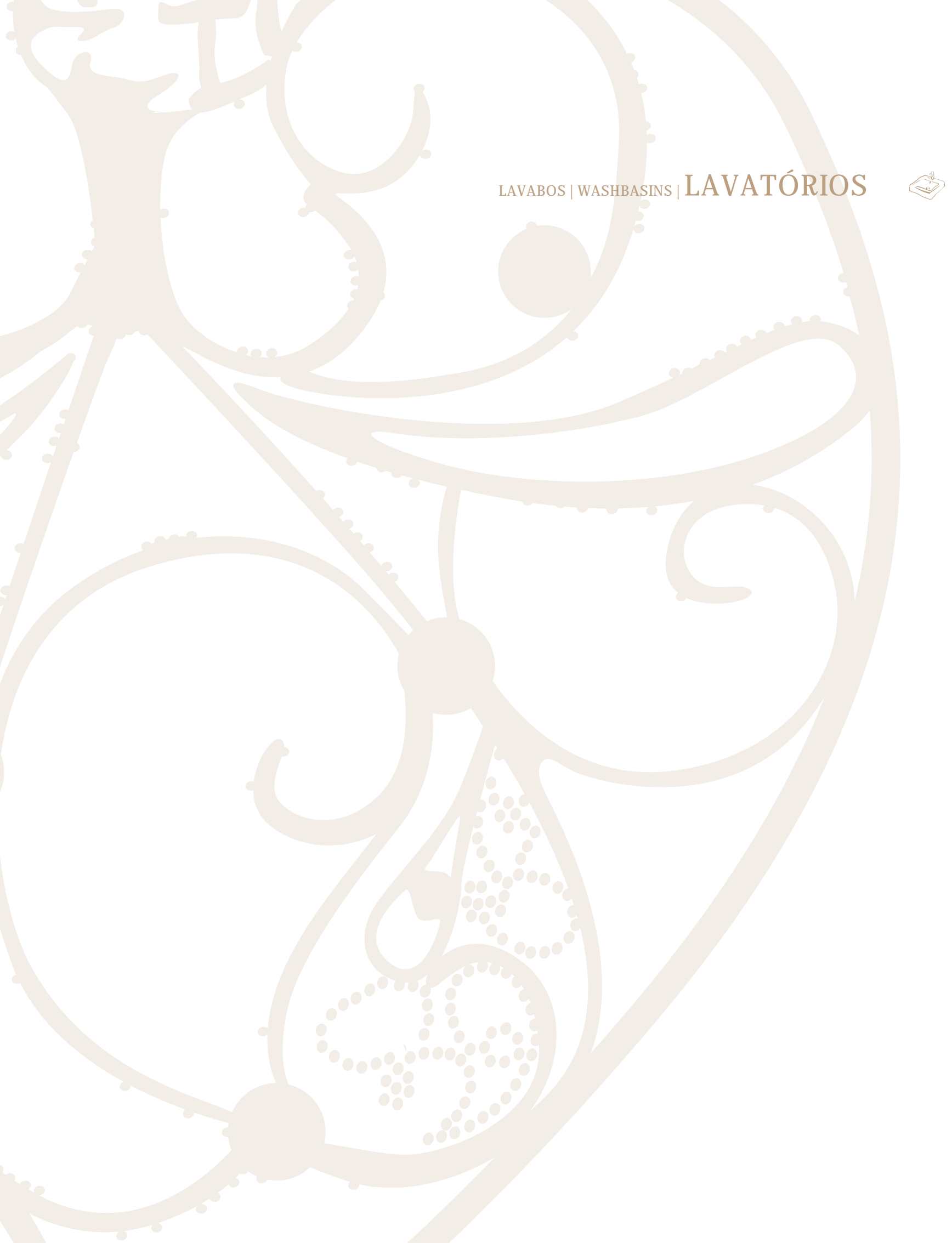

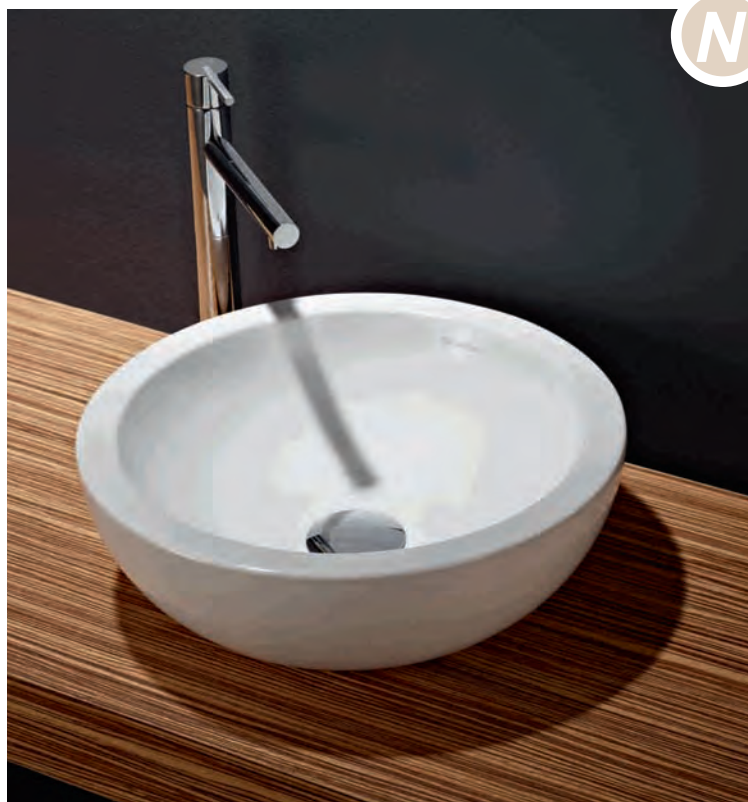

18797002 **Darke** (Ø 40 cm)

XX - CORES DISPONÍVEIS | AVAILABLE COLOURS | COULEURS DISPONIBLES
a) 00 (VER PÁG. 8 | SEE PAGE 8 | REGARDER PAGE.8)



18817002 **Daytona** (40 x 40 cm)

XX - CORES DISPONÍVEIS | AVAILABLE COLOURS | COULEURS DISPONIBLES
a) 00 (VER PÁG. 8 | SEE PAGE 8 | REGARDER PAGE.8)

39357XX2 **EGG** Lavatório pousar | Washbasin | Lavabo (50 x 38 cm)

CORES DISPONÍVEIS | AVAILABLE COLOURS | COULEURS DISPONIBLES
a) 00 (VER PÁG. 8 | SEE PAGE 8 | REGARDER PAGE 8)



Design: Gracinha Viterbo Arq. de Interiores - Atelier Graça Viterbo

LAVATÓRIOS

WASHBASINS | LAVABOS | LAVABOS



18862002 * **Vénus** torneira esq. | tap hole left | Trou gauche (44 x 34 cm)
 18863002 * **Vénus** torneira dir. | tap hole right | Trou droite (44 x 34 cm)

CORES DISPONÍVEIS | AVAILABLE COLOURS | COULEURS DISPONIBLES
 a) 00 (VER PÁG. 8 | SEE PAGE 8 | REGARDER PAGE 8)



18871XX2 **Urano** (Ø45 cm)

XX - CORES DISPONÍVEIS | AVAILABLE COLOURS | COULEURS DISPONIBLES
 a) 00 b) 48 (VER PÁG. 8 | SEE PAGE 8 | REGARDER PAGE 8)

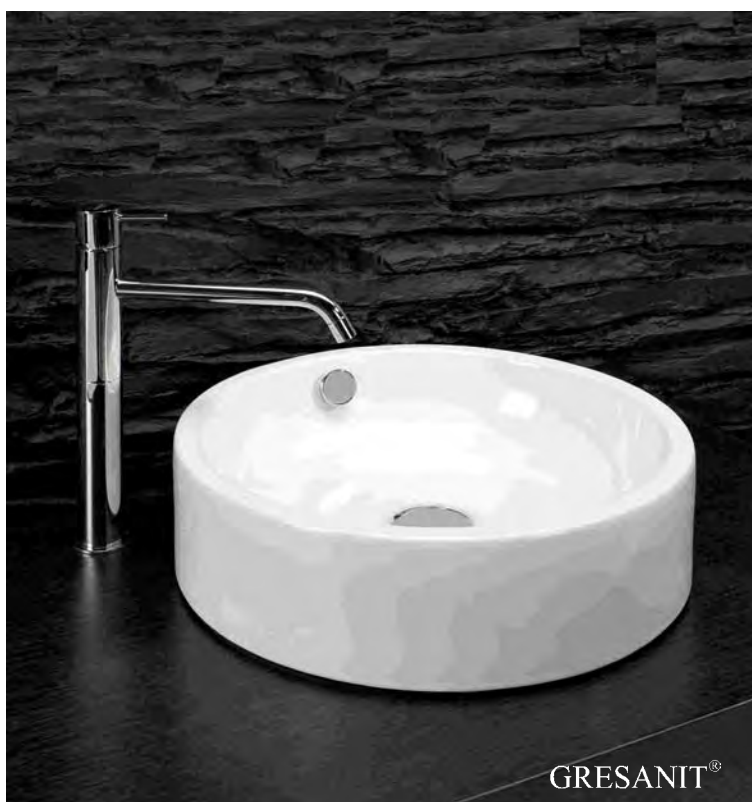

78737XX2 **Malibu** (Ø41,5 cm)

XX - CORES DISPONÍVEIS | AVAILABLE COLOURS | COULEURS DISPONIBLES
 a) 00 b) 48 (VER PÁG. 8 | SEE PAGE 8 | REGARDER PAGE 8)

GRESANIT®



LAVATÓRIOS
 WASHBASINS | LAVABOS | LAVABOS



32351002 **Assimétrica** Pousar | **Assimétrica** Drop in | **Assimétrica** Poser (51 x 58 cm)

CORES DISPONÍVEIS | AVAILABLE COLOURS | COULEURS DISPONIBLES
a) 00 (VER PÁG. 8 | SEE PAGE 8 | REGARDER PAGE 8)



34351002 **Nautilus** Pousar | **Nautilus** drop in | **Nautilus** Poser (51 x 51 cm)

CORES DISPONÍVEIS | AVAILABLE COLOURS | COULEURS DISPONIBLES
a) 00 (VER PÁG. 8 | SEE PAGE 8 | REGARDER PAGE 8)

18771XX2 **Atlanta** (55 x 45)

CORES DISPONÍVEIS | AVAILABLE COLOURS | COULEURS DISPONIBLES
a) 00-20 (VER PÁG. 8 | SEE PAGE 8 | REGARDER PAGE 8)



LAVATÓRIOS

WASHBASINS | LAVABOS | LAVABOS



78821002 **Gallery Dir** | **Gallery Right** | **Gallery Droite** (76 x 50 cm)
 78831002 **Gallery Esq** | **Gallery Left** | **Gallery Gauche** (76 x 50 cm)

CORES DISPONÍVEIS | AVAILABLE COLOURS | COULEURS DISPONIBLES
 a) 00 (VER PÁG. 8 | SEE PAGE 8 | REGARDER PAGE 8)



78811XX2 **Isis pousar** | **Isis drop in** | **Isis poser** (53 x 27 cm)
 78812XX2 **Isis Esq** | **Isis Left** | **Isis Gauche** (53 x 27 cm)
 78813XX2 **Isis Dir** | **Isis Right** | **Isis Droite** (53 x 27 cm)

XX - CORES DISPONÍVEIS | AVAILABLE COLOURS | COULEURS DISPONIBLES
 a) 00 | 48 (VER PÁG. 8 | SEE PAGE 8 | REGARDER PAGE.8)



18851002 **Eros** (32 x 32 cm)

CORES DISPONÍVEIS | AVAILABLE COLOURS | COULEURS DISPONIBLES
 a) 00 (VER PÁG. 8 | SEE PAGE 8 | REGARDER PAGE 8)



LAVATÓRIOS

WASHBASINS | LAVABOS | LAVABOS



18701XX2 **Miami** (Vidrado interior e exterior | glazed both sides | avec glaçure extérieure) (62 x 48 cm)

XX - CORES DISPONÍVEIS | AVAILABLE COLOURS | COULEURS DISPONIBLES
a) 00 | 16 | 20 b) 01 (VER PÁG. 8 | SEE PAGE 8 | REGARDER PAGE 8)



18717XX2 **Boston** (Vidrado interior e exterior | glazed both sides | avec glaçure extérieure) (Ø40 cm)

XX - CORES DISPONÍVEIS | AVAILABLE COLOURS | COULEURS DISPONIBLES
a) 00 | 16 | 20 b) 01 (VER PÁG. 8 | SEE PAGE 8 | REGARDER PAGE 8)

18801002 **Ceuta** (30 x 30 cm)

CORES DISPONÍVEIS | AVAILABLE COLOURS | COULEURS DISPONIBLES
a) 00 (VER PÁG. 8 | SEE PAGE 8 | REGARDER PAGE 8)



LAVATÓRIOS

WASHBASINS | LAVABOS | LAVABOS



78761XX2 **Recife Plus** (45 x 45 cm)

CORES DISPONÍVEIS | AVAILABLE COLOURS | COULEURS DISPONIBLES

a) 00 | 20 b) 48 (VER PÁG. 8 | SEE PAGE 8 | REGARDER PAGE 8)

Nota: Este lavatório foi desenvolvido para ser aplicado sob uma superfície.
No caso de pretender aplicá-lo à parede, por favor, confirmar no acto da encomenda.
This washbasin is designed to be applied on a surface. If you wish to apply it to wall,
please confirm at time of order.
Ce lavabo est destiné à être appliqué sur une surface. Si vous souhaitez l'appliquer
au mur, s'il vous plaît confirmer au moment de la commande.



18711XX2 **Rio** (45 x 45 cm)

CORES ESPECIAIS | SPECIAL COLOURS | COULEURS SPÉCIALES



48-PRETO, 35-ALFACE, 03-TANGERINA, 33-CEREJA
48-BLACK, 35-GREEN, 03-ORANGE, 33-RED
48-NOIR, 35-VERT, 03-MANDARINE, 33-CERISE

XX - CORES DISPONÍVEIS | AVAILABLE COLOURS | COULEURS DISPONIBLES

a) 00 | 20 b) 03 | 33 | 35 | 48 (VER PÁG. 8 | SEE PAGE 8 | REGARDER PAGE.8)



18781XX2 **Búzios** (45 x 45 cm)

CORES DISPONÍVEIS | AVAILABLE COLOURS | COULEURS DISPONIBLES

a) 00 | 20 (VER PÁG. 8 | SEE PAGE 8 | REGARDER PAGE 8)





Valadares

SEMI-ENCASTRAR | SEMI-ENCASTRABLE | SEMI-RECESSED



18751XX2 **Roma** (49 x 42 cm)

XX - CORES DISPONÍVEIS | AVAILABLE COLOURS | COULEURS DISPONIBLES
a) 00 | 16 | 20 b) 01 (VER PÁG. 8 | SEE PAGE 8 | REGARDER PAGE 8)



18341XX2 **Torino** (66 x 50 cm)

XX - CORES DISPONÍVEIS | AVAILABLE COLOURS | COULEURS DISPONIBLES
a) 00 | 16 | 20 b) 01 (VER PÁG. 8 | SEE PAGE 8 | REGARDER PAGE 8)

ENCASTRAR | ENCASTRABLE | RECESSED

18767XX2 **Missouri** (54 x 42 cm)

XX - CORES DISPONÍVEIS | AVAILABLE COLOURS | COULEURS DISPONIBLES
a) 00 | 20 (VER PÁG. 8 | SEE PAGE 8 | REGARDER PAGE 8)



LAVATÓRIOS

WASHBASINS | LAVABOS | LAVABOS



18777XX2 **Tânger** (55 x 35 cm)

XX - CORES DISPONÍVEIS | AVAILABLE COLOURS | COULEURS DISPONIBLES
a) 00 | 20 (VER PÁG. 8 | SEE PAGE 8 | REGARDER PAGE 8)



18327XX2 **Oval** (57 x 46 cm)

XX - CORES DISPONÍVEIS | AVAILABLE COLOURS | COULEURS DISPONIBLES
a) 00 | 16 | 20 b) 01 (VER PÁG. 8 | SEE PAGE 8 | REGARDER PAGE.8)



18326XX2 **Elipse** (51 x 41 cm)

XX - CORES DISPONÍVEIS | AVAILABLE COLOURS | COULEURS DISPONIBLES
a) 00 | 16 | 20 b) 01 (VER PÁG. 8 | SEE PAGE 8 | REGARDER PAGE 8)





18757XX2 **Danúbio** (52 x 42 cm)

XX - CORES DISPONÍVEIS | AVAILABLE COLOURS | COULEURS DISPONIBLES
a) 00 | 16 | 20 b) 01 (VER PÁG. 8 | SEE PAGE 8 | REGARDER PAGE 8)



18381XX2 **Nice** (Ø37 cm)

XX - CORES DISPONÍVEIS | AVAILABLE COLOURS | COULEURS DISPONIBLES
a) 00 | 16 | 20 b) 01 (VER PÁG. 8 | SEE PAGE 8 | REGARDER PAGE 8)

2.4 EMBUTIR | VANETY | POSER

18361XX2 **Miramar** (56 x 49 cm)

XX - CORES DISPONÍVEIS | AVAILABLE COLOURS | COULEURS DISPONIBLES
a) 00 | 16 | 20 b) 01 (VER PÁG. 8 | SEE PAGE 8 | REGARDER PAGE 8)



LAVATÓRIOS
WASHBASINS | LAVABOS | LAVABOS



18351XX2 **Brava** (57 x 44 cm)

XX - CORES DISPONÍVEIS | AVAILABLE COLOURS | COULEURES DISPONIBLES
a) 00 | 16 | 20 b) 01 (VER PÁG. 8 | SEE PAGE 8 | REGARDER PAGE 8)



18391XX2 **Nilo** (47 x 49 cm)

XX - CORES DISPONÍVEIS | AVAILABLE COLOURS | COULEURES DISPONIBLES
a) 00 | 16 | 20 b) 01 (VER PÁG. 8 | SEE PAGE 8 | REGARDER PAGE.8)



- 18841002 **Oasis** 1F (Torneira ao centro | Center tap| Trou central) (57 x 46 cm)
- 18842002 **Oasis** 1F (Torneira esq) | Tap hole left | Trou gauche) (57 x 46 cm)
- 18843002 **Oasis** 1F (Torneira dir) | Tap hole right| Trou droite) (57 x 46 cm)

CORES DISPONÍVEIS | AVAILABLE COLOURS | COULEURES DISPONIBLES
a) 00 (VER PÁG. 8 | SEE PAGE 8 | REGARDER PAGE 8)



LAVATÓRIOS
WASHBASINS | LAVABOS | LAVABOS



18386XX2 **Mónaco** (não vidrado pelo exterior | unglazed on the outside
| sans glaçure extérieur) (Ø41 cm)*
18387XX2 **Mónaco** (Ø41 cm)*
XX - CORES DISPONÍVEIS | AVAILABLE COLOURS | COULEURS DISPONIBLES
a) 00 | 16 | 20 b) 01 (VER PÁG. 8 | SEE PAGE 8 | REGARDER PAGE 8)



78707XX2 **Goa** (Ø43 cm)
XX - CORES DISPONÍVEIS | AVAILABLE COLOURS | COULEURS DISPONIBLES
a) 00 | 20 (VER PÁG. 8 | SEE PAGE 8 | REGARDER PAGE 8)

18807002 **Palm** (Ø40 cm)
CORES DISPONÍVEIS | AVAILABLE COLOURS | COULEURS DISPONIBLES
a) 00 (VER PÁG. 8 | SEE PAGE 8 | REGARDER PAGE 8)

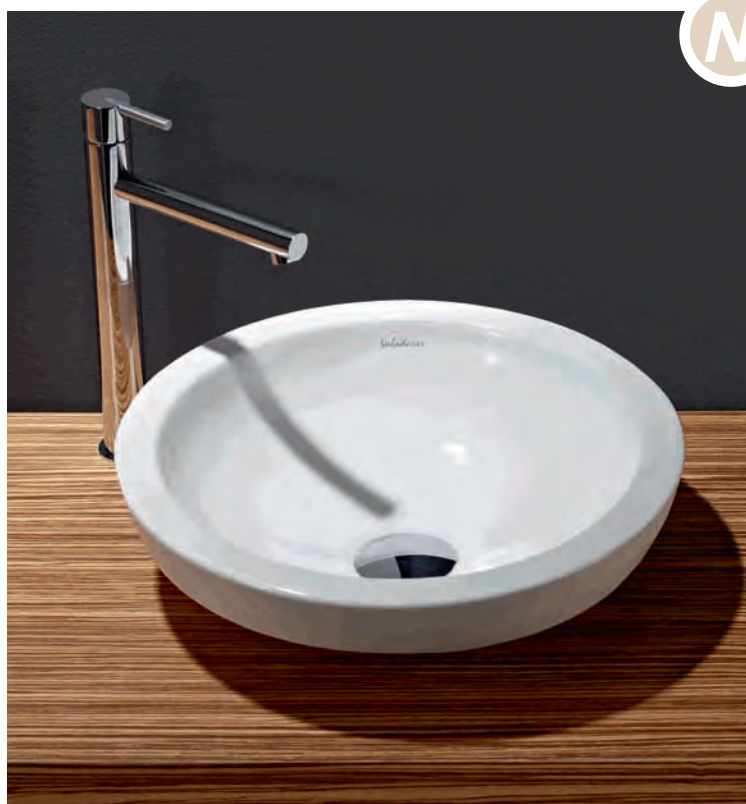

LAVATÓRIOS

WASHBASINS | LAVABOS | LAVABOS



18301XX2 | **Top** (56 x 44 cm)

XX - CORES DISPONÍVEIS | AVAILABLE COLOURS | COULEURS DISPONIBLES
a) 00 | 16 | 20 b) 01 (VER PÁG. 9 | SEE PAGE 9 | REGARDER PAGE 9)



55330000 | Móvel p/ lavatório **Top** | Cupboard for Top | Meuble Top (51 x 81 cm)

XX - CORES DISPONÍVEIS | AVAILABLE COLOURS | COULEURS DISPONIBLES
a) 00 (VER PÁG. 8 | SEE PAGE 8 | REGARDER PAGE.8)



18741XX2 | **Top Plus** (65 x 45 cm)

XX - CORES DISPONÍVEIS | AVAILABLE COLOURS | COULEURS DISPONIBLES
a) 00 | 16 | 20 b) 01 (VER PÁG. 8 | SEE PAGE 8 | REGARDER PAGE.8)



55331000 | Móvel p/ lavatório **Top Plus**
Cupboard for Top Plus | Meuble p/Top Plus (61 x 80 cm)

XX - CORES DISPONÍVEIS | AVAILABLE COLOURS | COULEURS DISPONIBLES
a) 00 (VER PÁG. 8 | SEE PAGE 8 | REGARDER PAGE.8)

* Inclui parafusos de fixação | With fixing screws | Avec vis de fixation



Valadares



GRESANIT®

70042XX2 Placa nº 1 cerâmica c/ fur. central | Ceramic top n.1 with central hole | Tablette porcelaine n.1 avec trou central (60x50 cm)

70045XX2 Placa nº 2 cerâmica c/ fur. central | Ceramic top n.2 with central hole | Tablette porcelaine n.2 avec trou central (60x50 cm)

XX - CORES DISPONÍVEIS | AVAILABLE COLOURS | COULEURS DISPONIBLES
a) 00 | 48 (VER PÁG. 8 | SEE PAGE 8 | REGARDER PAGE 8)

70242XX2 Placa nº 1 cerâmica c/fur. central | Ceramic top n.1 with central hole | Tablette porcelaine n.1 avec trou central (100x50 cm)

70243XX2 Placa nº 1 cerâmica c/fur. esq. | Ceramic top n.1 with left hole | Tablette porcelaine n.1 avec trou gauche (100x50 cm)

70246XX2 Placa nº 2 cerâmica c/fur. esq. | Ceramic top n.2 with left hole | Tablette porcelaine n.2 avec trou gauche (100x50 cm)

70244XX2 Placa nº 1 cerâmica c/fur. dir. | Ceramic top n.1 with right hole | Tablette porcelaine n.1 avec trou droite (100x50 cm)

70247XX2 Placa nº 2 cerâmica c/fur. dir. | Ceramic top n.2 with right hole | Tablette porcelaine n.2 avec trou droite (100x50 cm)

XX - CORES DISPONÍVEIS | AVAILABLE COLOURS | COULEURS DISPONIBLES
a) 00 | 48 (VER PÁG. 8 | SEE PAGE 8 | REGARDER PAGE 8)

LAVATÓRIOS

WASHBASINS | LAVABOS | LAVABOS



GRESANIT®

70142XX2 Placa nº 1 cerâmica c/fur. central | Ceramic top n.1 with central hole | Tablette porcelaine n.1 avec trou central (80x50 cm)

70143XX2 Placa nº 1 cerâmica c/fur. esq. | Ceramic top n.1 with left hole | Tablette porcelaine n.1 avec trou gauche (80x50 cm)

70146XX2 Placa nº 2 cerâmica c/fur. esq. | Ceramic top n.2 with left hole | Tablette porcelaine n.2 avec trou gauche (80x50 cm)

70144XX2 Placa nº 1 cerâmica c/fur. dir. | Ceramic top n.1 with right hole | Tablette porcelaine n.1 avec trou droite (80x50 cm)

70147XX2 Placa nº 2 cerâmica c/fur. dir. | Ceramic top n.2 with right hole | Tablette porcelaine n.2 avec trou droite (80x50 cm)

XX - CORES DISPONÍVEIS | AVAILABLE COLOURS | COULEURS DISPONIBLES
a) 00 | 48 (VER PÁG. 8 | SEE PAGE 8 | REGARDER PAGE 8)



GRESANIT®

NOTA: As placas nº 1 são compatíveis com os lavatórios: Miami, Recife Plus, Rio, Nautilus, Atlanta e Urano. | As placas nº 2 são compatíveis com os lavatórios: Malibu, Boston e Ísis.

PS: This ceramic top n.1 is suitable to: Miami, Recife Plus, Rio, Nautilus, Atlanta e Urano. | This ceramic top n.2 is suitable to: Malibu, Boston e Ísis.

PS: Cet tablette n.1 porcelaine son compatible avec: Miami, Recife Plus, Rio, Nautilus, Atlanta e Urano. | Cet tablette n.2 porcelaine son compatible avec: Malibu, Boston e Ísis.



- 55320003 Móvel **IKO** 60 cm lacado Branco | Furniture IKO 60 cm lacquered white | Meuble IKO 60 cm laqué blanc
- 55320483 Móvel **IKO** 60 cm lacado Preto | Furniture IKO 60 cm lacquered black | Meuble IKO 60 cm laqué noir
- 55320740 Móvel **IKO** 60 cm contraplacado marítimo Wenguê | Furniture IKO 60 cm maritime wood Wenguê | Meuble **IKO** 60 cm bois maritimé Wenguê
- 55325740 Porta p/ móvel **IKO** 60 cm wenguê | Door IKO 60 cm wenguê | Porte IKO 60 cm wenguê
- 55325000 Porta p/ móvel **IKO** 60 cm branca | Door IKO 60 cm white | Porte IKO 60 cm blanc
- 55325480 Porta p/ móvel **IKO** 60 cm preta | Door IKO 60 cm black | Porte IKO 60 cm noir
- 55325330 Porta p/ móvel **IKO** 60 cm cereja | Door IKO 60 cm chery | Porte IKO 60 cm cerise
- 55325350 Porta p/ móvel **IKO** 60 cm verde | Door IKO 60 cm green | Porte IKO 60 cm verte
- 55325030 Porta p/ móvel **IKO** 60 cm tangerina | Door IKO 60 cm orange | Porte IKO 60 cm orange



- 55321003 Móvel **IKO** 80 cm lacado Branco | Furniture IKO 80 cm lacquered white | Meuble IKO 80 cm laqué blanc
- 55321483 Móvel **IKO** 80 cm lacado Preto | Furniture IKO 80 cm lacquered black | Meuble IKO 80 cm laqué noir
- 55321740 Móvel **IKO** 80 cm contraplacado marítimo Wenguê | Furniture IKO 80 cm maritime wood Wenguê | Meuble **IKO** 80 cm bois maritimé Wenguê
- 55326740 Porta p/ móvel **IKO** 80 cm wenguê | Door IKO 80 cm wenguê | Porte IKO 80 cm wenguê
- 55326000 Porta p/ móvel **IKO** 80 cm branca | Door IKO 80 cm white | Porte IKO 80 cm blanc
- 55326480 Porta p/ móvel **IKO** 80 cm preta | Door IKO 80 cm black | Porte IKO 80 cm noir
- 55326330 Porta p/ móvel **IKO** 80 cm cereja | Door IKO 80 cm chery | Porte IKO 80 cm cerise
- 55326350 Porta p/ móvel **IKO** 80 cm verde | Door IKO 80 cm green | Porte IKO 80 cm verte
- 55326030 Porta p/ móvel **IKO** 80 cm tangerina | Door IKO 80 cm orange | Porte IKO 80 cm orange



- 55322003 Móvel **IKO** 100 cm lacado Branco | Furniture IKO 100 cm lacquered white | Meuble IKO 100 cm laqué blanc
- 55322483 Móvel **IKO** 100 cm lacado Preto | Furniture IKO 100 cm lacquered black | Meuble IKO 100 cm laqué noir
- 55322740 Móvel **IKO** 100 cm contraplacado marítimo Wenguê | Furniture IKO 100 cm maritime wood Wenguê | Meuble **IKO** 100 cm bois maritimé Wenguê
- 55327740 Porta p/ móvel **IKO** 100 cm wenguê | Door IKO 100 cm wenguê | Porte IKO 100 cm wenguê
- 55327000 Porta p/ móvel **IKO** 100 cm branca | Door IKO 100 cm white | Porte IKO 100 cm blanc
- 55327480 Porta p/ móvel **IKO** 100 cm preta | Door IKO 100 cm black | Porte IKO 100 cm noir
- 55327330 Porta p/ móvel **IKO** 100 cm cereja | Door IKO 100 cm chery | Porte IKO 100 cm cerise
- 55327350 Porta p/ móvel **IKO** 100 cm verde | Door IKO 100 cm green | Porte IKO 100 cm verte
- 55327030 Porta p/ móvel **IKO** 100 cm tangerina | Door IKO 100 cm orange | Porte IKO 100 cm orange

Os móveis IKO são concebidos para terem como tampo as placas cerâmicas Valadares
 IKO furniture are designed to have ceramic top Valadares | Meubles IKO sont destinés pour avoir des assiettes en céramique Valadares



XX - CORES DISPONÍVEIS (portas) | AVAILABLE COLOURS (doors) | COULEURS DISPONIBLES (PORTES): a) 00 | 20 | b) 03 | 33 | 35 | 48 (VER PÁG. 8 | SEE PAGE 8 | REGARDER PAGE 8)

- 00
BRANCO
WHITE
BLANC
-  48
PRETO
BLACK,
NOIR
-  35
ALFACE
GREEN
VERT
-  03
TANGERINA
ORANGE
MANDARINE
-  35
CEREJA
RED
CERISE



Valadares



Platinum (60 cm)



Platinum (90 cm)

- 79301 **Platinum** 60 cm 1F. | 1Hole | 1Trou
- 79322 **Platinum** 80 cm 1F. Esq./ Dir. | 1Hole Left Right | 1Trou Gauche/ Droite
- 79332 **Platinum** 90 cm 1F. Esq./ Dir. | 1Hole Left Right | 1Trou Gauche/ Droite
- 79342 **Platinum** 100 cm 1F. Esq./ Dir. | 1Hole Left Right | 1Trou Gauche/ Droite
- 79362 **Platinum** 120 cm 1F. Esq./ Dir. | 1Hole Left Right | 1Trou Gauche/ Droite

XX - CORES DISPONÍVEIS | AVAILABLE COLOURS | COULEURS DISPONIBLES
a) 00 (VER PÁG. 8 | SEE PAGE 8 | REGARDER PAGE 8)

LAVATÓRIOS
WASHBASINS | LAVABOS | LAVABOS



PLATINIUM (90 cm)



- 55340480 Móvel OKI 60 cm (preto / black / noir)
- 55341480 Móvel OKI 80 cm (preto / black / noir)
- 55342480 Móvel OKI 90 cm (preto / black / noir)
- 55343480 Móvel OKI 100 cm (preto / black / noir)
- 55344480 Móvel OKI 120 cm (preto / black / noir)

Os móveis OKI é concebido para aplicação de lavatório Platinum.
 Oki furniture is designed for Platinum washbasin.
 Meubles OKI sont destinés pour lavabo Platinum.



55350XX0 | Móvel ISIS | Meuble | Furniture

55109121 | Sifão em latão p/ lavatório | Chromed brass Siphon | Siphon Chromé en laiton



* Inclui parafusos de fixação | With fixing screws | Avec vis de fixation

PIÈCES TECHNIQUES | TECHNICAL PIECES | PEÇAS TÉCNICAS





GRESANIT®

7861002 | Monchique (38 x 38 cm)

XX - CORES DISPONÍVEIS
 AVAILABLE COLOURS | COULEURS DISPONIBLES
 a) 00 (VER PÁG. 8 | SEE PAGE 8 | REGARDER PAGE.8)



GRESANIT®

78615002 | Sintra (48 x 38 cm)

XX - CORES DISPONÍVEIS
 AVAILABLE COLOURS | COULEURS DISPONIBLES
 a) 00 (VER PÁG. 8 | SEE PAGE 8 | REGARDER PAGE.8)



GRESANIT®

78616002 | Silves (54 x 40 cm)

XX - CORES DISPONÍVEIS
 AVAILABLE COLOURS | COULEURS DISPONIBLES
 a) 00 (VER PÁG. 8 | SEE PAGE 8 | REGARDER PAGE.8)

PEÇAS TÉCNICAS

TECHNICAL PIECES | PIÈCES TECHNIQUES

12361XX2 | Lava-mãos (45 x 34 cm)
 Hand washbasin
 Lave-mains

XX - CORES DISPONÍVEIS
 AVAILABLE COLOURS | COULEURS DISPONIBLES
 a) 00 | 16 | 20 (VER PÁG. 8 | SEE PAGE 8 | REGARDER PAGE.8)



* Inclui parafusos de fixação | With fixing screws | Avec vis de fixation



18613002 | Pia Hospitalar c/ ralo cerâmico | Medical Slop hopper
with ceramic strainer | Évier hôpital crépine céramique
55003001 | Grade inox p/ pia hospitalar | Grade inox | Grille acier

XX - CORES DISPONÍVEIS
AVAILABLE COLOURS | COULEURS DISPONIBLES
a) 00 (VER PÁG. 8 | SEE PAGE 8 | REGARDER PAGE.8)



18041002 | * Bacia BTW | Wc BTW | Wc BTW

XX - CORES DISPONÍVEIS
AVAILABLE COLOURS | COULEURS DISPONIBLES
a) 00 (VER PÁG. 8 | SEE PAGE 8 | REGARDER PAGE.8)



18640002 | Bacia turca | Squatting Wc pan (turkish)
Wc turc

XX - CORES DISPONÍVEIS
AVAILABLE COLOURS | COULEURS DISPONIBLES
a) 00 (VER PÁG. 8 | SEE PAGE 8 | REGARDER PAGE.8)



GRESANIT®



78660002 | Mozela (52 x 45 cm) (sem válvula) | without valve | sans vidage
55332000 | Móvel para lava-roupa Mozela | Cabinet Mozela | Mueble Mozela (Altura | High |
Hauter 80cm)

XX - CORES DISPONÍVEIS
AVAILABLE COLOURS | COULEURS DISPONIBLES
a) 00 (VER PÁG. 8 | SEE PAGE 8 | REGARDER PAGE.8)

* Inclui parafusos de fixação | With fixing screws | Avec vis de fixation



BACS À DOUCHE | SHOWER TRAYS | **BASES DE CHUVEIRO**



BASES DE CHUVEIRO

SHOWER TRAYS | BACS À DOUCHE

BASES DE CHUVEIRO EM GRESANIT | SHOWER TRAYS GRESANIT | BACS À DOUCHE GRESANIT

MENOR ABSORÇÃO DE ÁGUA

| LOWER ABSORPTION OF WATER | MOINS ABSORPTION D'EAU

MAIOR RESISTÊNCIA À ABRASÃO

| MORE RESISTENCE ABRASION | PLUS GRAND RÉSIDENCE L'ABRASION

MAIOR RESISTÊNCIA À FENDILHAGEM

| MORE RESISTENCE CLACKING | PLUS GRAND RÉSIDENCE TRAISSAILLAGE

MAIOR RESISTÊNCIA AO IMPACTO

| MORE RESISTENCE IMPACT | PLUS GRAND RÉSIDENCE IMPACT

EXCELENTE RESISTÊNCIA MECÂNICA

| MORE MECHANICAL RESISTENCE | PLUS GRAND MÉCANIQUE RÉSIDENCE

EXCELENTE RESISTÊNCIA A AGENTES QUÍMICOS

| EXCELLENTE RESISTENCE TO CHEMICAL AGENTS

| EXCELLENTE RÉSIDENCE AUX AGENTS CHIMIQUES

FACILIDADE DE INSTALAÇÃO

| EASY INSTALATION | FACILITÉ D'INSTALLATION

GAMA DE DIMENSÕES BASTANTE ABRANGENTE

| VERY COMPREHENSIVE RARTIZ | GAMME TRÉS COMPLÈTE

GARANTIA DE 20 ANOS CONTRA DEFEITOS DE FABRICO

| 20 YEARS GUARANTEE AGAINST MANUFACTURING DEFECTS

| 20 ANNÉES DE GARANTIE CONTRE DÉFAUTS DE FABRICATION



BASES DE CHUVEIRO

SHOWER TRAYS | BACS À DOUCHE

39673002 | **EGG** (90 x 90 cm x 5 cm)

XX - CORES DISPONÍVEIS | AVAILABLE COLOURS | COULEURS DISPONIBLES
a) 00 (VER PÁG. 8 | SEE PAGE 8 | REGARDER PAGE.8)

Design: Gracinha Viterbo Arq. de Interiores - Atelier Graça Viterbo

18637XX2 | **Guadiana** (80 x 80 x 8,5 cm) (porcelana | vitrous china | porcelain)
55124100 Estrado **Guadiana** contraplacado marítimo
Wooden tray **Guadiana** | Podium **Guadiana** bois maritime

CORES DISPONÍVEIS | AVAILABLE COLOURS | COULEURS DISPONIBLES
a) 00 | 20 (VER PÁG. 8 | SEE PAGE 8 | REGARDER PAGE 8)



PORCELANA / QUADRADAS | PORCELAINE CARRÉ | VITREOUS CHINA QUARE

18630XX2 | **Lima** (70 x 70 x 4,0 cm) (porcelana | vitrous china | porcelain)
55124070 Estrado **Lima** em contraplacado marítimo | Wooden tray **Lima**
Podium **Lima** bois maritime

XX - CORES DISPONÍVEIS | AVAILABLE COLOURS | COULEURS DISPONIBLES
a) 00 | 20 (VER PÁG. 8 | SEE PAGE 8 | REGARDER PAGE.8)



BASES DE CHUVEIRO

SHOWER TRAYS | BACS À DOUCHE

78670XX2 **Douro Plus** (80 x 80 x 5 cm) (porcelana | vitreous china | porcelain)

CORES DISPONÍVEIS | AVAILABLE COLOURS | COULEURS DISPONIBLES
a) 00 | 20 (VER PÁG. 8 | SEE PAGE 8 | REGARDER PAGE.8)

78639002 **Aqua** (90 x 90 x 5,5cm) *

CORES DISPONÍVEIS | AVAILABLE COLOURS | COULEURS DISPONIBLES
a) 00 (VER PÁG. 8 | SEE PAGE 8 | REGARDER PAGE 8)

* Produto Incluído na rubrica "WC p/ Pessoas com Mobilidade Reduzida"
* Included in the product line "Accessible toilets" | * Inclus dans la ligne de produits "Handicapé"



GRESANIT®

PORCELANA/RECTANGULARES | VITREOUS CHINA RECTANGULAR | PORCELAINE RECTANGULAIRE

78631002 **Danilo** (90 x 70 x 5,0cm)

XX - CORES DISPONÍVEIS | AVAILABLE COLOURS | COULEURS DISPONIBLES
a) 00 VER PÁG. 8 | SEE PAGE 8 | REGARDER PAGE.8)



GRESANIT®



GRESANIT®



BASES DE CHUVEIRO

SHOWER TRAYS | BACS À DOUCHE

78632002 | **Lusa** (90 x 70 x 6,0 cm)

XX - CORES DISPONÍVEIS | AVAILABLE COLOURS | COULEURS DISPONIBLES
a) 00 VER PÁG. 8 | SEE PAGE 8 | REGARDER PAGE.8)

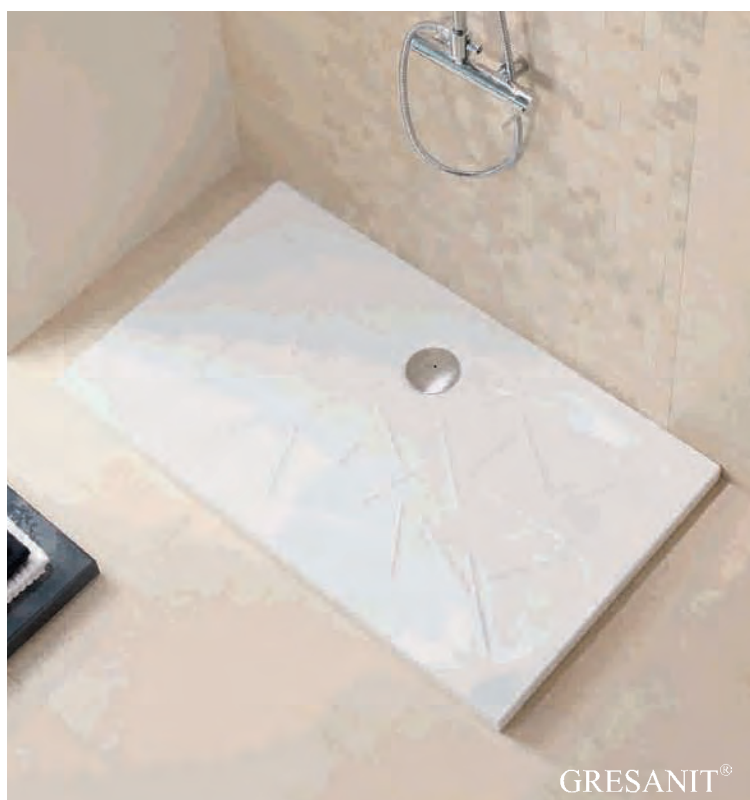

78633002 | **Aris** (100 x 70 x 4,5 cm)
46500002 | **Aris** c/sistema de aquecimento Warmup
Aris with Heating system | **Aris** avec système de chauffage (100 x 70 x 4,5 cm)
78634002 | **Aris** (120 x 70 x 4,5 cm)
46501002 | **Aris** c/sistema de aquecimento Warmup
Aris with Heating system | **Aris** avec système de chauffage (120 x 70 x 4,5 cm)

Nota: Opção base com aquecimento (pág. 80)
P.s: Option shower tray with heating system (page. 80)
P.s: Option bac douche avec chauffage (page. 80)

CORES DISPONÍVEIS | AVAILABLE COLOURS | COULEURS DISPONIBLES
a) 00 (VER PÁG. 8 | SEE PAGE 8 | REGARDER PAGE 8)



BASES DE CHUVEIRO

SHOWER TRAYS | BACS À DOUCHE

78635002 **Padua** (100 x 80 x 4,5 cm)
78636002 **Padua** (120 x 80 x 4,5 cm)

XX - CORES DISPONÍVEIS | AVAILABLE COLOURS | COULEURS DISPONIBLES
a) 00 b) 48 (VER PÁG. 8 | SEE PAGE 8 | REGARDER PAGE.8)



78671002 **Luca** (140 X 70 x 4,5 cm)
78672002 **Luca** (140 X 80 x 4,5 cm)

CORES DISPONÍVEIS | AVAILABLE COLOURS | COULEURS DISPONIBLES
a) 00 (VER PÁG. 8 | SEE PAGE 8 | REGARDER PAGE 8)



BASE DE CHUVEIRO COM AQUECIMENTO INTEGRADO - WARMUP

* Para Base de Chuveiro ARIS

CARACTERÍSTICAS

Base de chuveiro Valadares, em GRESANIT[®], com adaptação de resistência Warmup com 110W de potência, com corrente de 24V e 4,6A.

Temperatura da superfície de aproximadamente 30°C com sistema de controlo. Tempo de aquecimento de cerca de 20 a 30 minutos.

Utilização de transformador 220V/24V.

Equipamento fornecido com a base: cabo de ligação ao transformador; transformador. Garantia de 5 anos contra defeitos de fabrico.

DADOS DE INSTALAÇÃO

A base de chuveiro não deverá ser encastrada na parede, de forma a ser facilitado o acesso em caso de anomalia. Fazer vedação com silicone ou similar.

O cabo de alimentação da base de chuveiro tem um comprimento de 6m e é já fornecido devidamente instalado na base. A sua ligação à base de chuveiro não deverá ser violada. Este cabo poderá ser cortado no lado de ligação ao transformador, em função das características da instalação. O transformador (fornecido) será instalado entre a fonte de alimentação e a base de chuveiro. A distância máxima entre o transformador e a base é de 6m. Deverá ser instalado numa caixa eléctrica encastrada na parede com protecção de humidade mínima IP65.

Na linha de alimentação ao transformador deverá ser instalado um interruptor ON/OFF (não fornecido), a colocar junto aos interruptores de iluminação da casa de banho (recomendado).

Na linha de alimentação à base de chuveiro é obrigatória a instalação de um disjuntor diferencial de 30mA, o qual deverá ser instalado no quadro eléctrico da habitação.

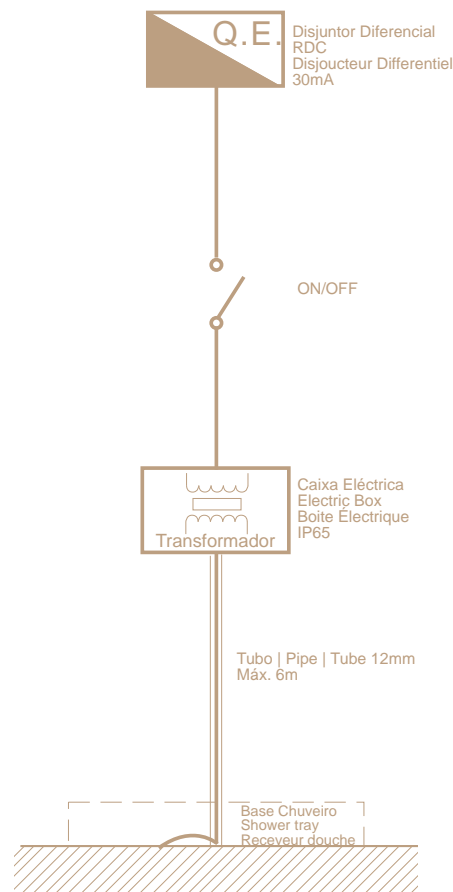

SHOWER TRAY WITH HEATING SYSTEM - WARMUP

* For Shower Tray ARIS

CHARACTERISTICS

Shower Tray Valadares, in GRESANIT[®], with adaptation of resistance Warmup with 110W of power, with a voltage of 24V and current of 4.6 A.

Surface temperature is around 30° C with a heating control system. Warm up time about 20 to 30 minutes.

Use of 220V/24V transformer.

Equipment provided with the Shower Tray: cable for connecting to the transformer; transformer. Guarantee of 5 years against defects in workmanship.

INSTALLATION DATA

The Shower Tray should not be recessed in the wall to guarantee an easier access in case of failure. Make sealing with silicone or similar.

The cable from the shower tray has a 6 meters length and is already supplied with the shower tray. This connection to the shower tray should not be violated. The cable can be cut to provide the connection to the transformer, depending on bathroom's layout.

Transformer (supplied) will be installed between the power supply and shower tray. The maximum distance between the transformer and the shower tray is 6 m. It should be installed in an electricity box recessed in the wall with protection from moisture minimum IP65.

In the power supply to the transformer should be installed a switch ON / OFF (not supplied), to put it near the switches for bathroom's lighting (recommended).

In the power supply to the shower tray is obligatory installation of RCD of 30mA, which must be installed on the switchboard of housing.

BAC À DOUCHE AVEC CHAUFFAGE | WARMUP

* Pour Bac à douche ARIS

CARACTÉRISTIQUES

Receveur de douche Valadares fabriqué en GRESANIT[®] avec adaptation de résistance électrique Warmup de 110W, 24V et 4,6A

Température de surface approximée aux 30°C, avec système de contrôle. Temps de chauffage de 20 a 30 minutes.

Utilisation de transformateur 220V / 24V.

Equipement fourni avec le receveur : câble de liaison au transformateur ; transformateur.

Garantie de 5 années contre défauts de fabrication.

DONNÉS POUR INSTALLATION

Le receveur ne devra pas être encastré dans la paroi, de façon a faciliter l'accès en cas de dommage. Serrer avec silicone ou similaire.

Le câble de liaison du receveur au transformateur a une longueur de 6m et est déjà connecté à la résistance du receveur. Sa liaison au receveur ne devra pas être violée. Ce câble pourra être coupé a la coté de liaison au transformateur en fonction des caractéristiques de l'installation.

Le transformateur (fourni) devra être installé entre la fonte d'alimentation et le receveur. La distance maximale entre le transformateur et le receveur est de 6m. Installer le transformateur dans une boîte électrique avec protection d'humidité minimale IP65.

Dans la ligne d'alimentation au transformateur devra être installé un interrupteur ON / OFF (pas fourni), lequel pourra être placé près des interrupteurs des lumières de la salle a bains (recommandé).

Dans la ligne électrique du receveur est obligatoire l'installation d'un disjoncteur différentiel de 30mA (pas fourni), lequel devra être placé dans le cadre électrique de la maison.



Valadares

ACRÍLICAS ANGULARES | ANGLE ACRYLIC | ACRYLIQUE ANGLE

BASES DE CHUVEIRO

SHOWER TRAYS | BACS À DOUCHE

52429000 **Trebbo** (90 x 90 x 10 cm)
55124390 Estrado **Trebbo** | Wooden tray **Trebbo** | Podium **Trebbo**
(90 x 90 x 2,9 cm)

CORES DISPONÍVEIS | AVAILABLE COLOURS | COULEURS DISPONIBLES
a) 00 (VER PÁG. 8 | SEE PAGE 8 | REGARDER PAGE 8)



ACRÍLICAS QUADRADAS | SQUARE ACRYLIC | ACRYLIQUE CARRÉ

52424005 **Bernini** (90 x 90 x 7,5 cm)
55124245 Estrado **Bernini** | Wooden tray **Bernini** | Podium **Bernini** (90 x 90 x 2,9 cm)
52418005 **Bernini** (80 x 80 x 7,5 cm)
55124275 Estrado **Bernini** | Wooden tray **Bernini** | Podium **Bernini** (80 x 80 x 2,9 cm)
52417005 **Bernini** (75 x 75 x 7,5 cm)
55124265 Estrado **Bernini** | Wooden tray **Bernini** | Podium **Bernini** (75 x 75 x 2,9 cm)
52416005 **Bernini** (70 x 70 x 7,5 cm)
55124255 Estrado **Bernini** | Wooden tray **Bernini** | Podium **Bernini** (70 x 70 x 2,9 cm)

CORES DISPONÍVEIS | AVAILABLE COLOURS | COULEURS DISPONIBLES
a) 00 (VER PÁG. 8 | SEE PAGE 8 | REGARDER PAGE 8)





BASES DE CHUVEIRO

SHOWER TRAYS | BACS À DOUCHE

- 52442006 **Duccio** (170 x 70 x 7,5 cm)
- 52445006 **Duccio** (170 x 75 x 7,5 cm)
- 52464006 **Duccio** (170 x 80 x 7,5 cm)
- 52438006 **Duccio** (160 x 80 x 7,5 cm)
- 55124366 Estrado **Duccio** (160 x 80 x 2,9 cm)
- 52439006 **Duccio** (140 x 80 x 7,5 cm)
- 55124376 Estrado **Duccio** (140 x 80 x 2,9 cm)
- 52437006 **Duccio** (120 x 80 x 7,5 cm)
- 55124356 Estrado **Duccio** (120 x 80 x 2,9 cm)
- 52436006 **Duccio** (100 x 80 x 7,5 cm)
- 55124346 Estrado **Duccio** (100 x 80 x 2,9 cm)
- 52433006 **Duccio** (140 x 75 x 7,5 cm)
- 55124336 Estrado **Duccio** (140 x 75 x 2,9 cm)
- 52432006 **Duccio** (120 x 75 x 7,5 cm)
- 55124326 Estrado **Duccio** (120 x 75 x 2,9 cm)
- 52431006 **Duccio** (100 x 75 x 7,5 cm)
- 55124316 Estrado **Duccio** (100 x 75 x 2,9 cm)
- 52428006 **Duccio** (90 x 75 x 7,5 cm)
- 55124386 Estrado **Duccio** (90 x 75 x 2,9 cm)
- 52423006 **Duccio** (120 x 70 x 7,5 cm)
- 55124296 Estrado **Duccio** (120 x 70 x 2,9 cm)
- 52419006 **Duccio** (100 x 70 x 7,5 cm)
- 55124286 Estrado **Duccio** (100 x 70 x 2,9 cm)

CORES DISPONÍVEIS | AVAILABLE COLOURS | COULEURS DISPONIBLES
a) 00 VER PÁG. 8 | SEE PAGE 8 | REGARDER PAGE.8)



- 52606XX0 **Sena** (70 x 70 x 3,0 cm) (2)
- 52607XX0 **Sena** (80 x 80 x 3,0 cm) (1)

CORES DISPONÍVEIS | AVAILABLE COLOURS | COULEURS DISPONIBLES
a) 00 - 20 VER PÁG. 8 | SEE PAGE 8 | REGARDER PAGE.8)



- 55019011 Válvula sifonada Viega p/ base chuveiro c furo \varnothing 60 mm | Valve shower tray with waste hole \varnothing 60 mm | Vidage p/bac douche trou \varnothing 60 mm
- 55151050 Válvula sifonada Wirquin p/ base de chuveiro c/ furos \varnothing 50 e 60 mm | Valve Wirquin for shower tray with waste hole \varnothing 50 & 60 mm | Vidage Wirquin p/ bac douche avec trou \varnothing 50 e 60 mm
- 55019001 Válvula sifonada Viega p/ base de chuveiro c/ furo \varnothing 90 mm | Valve for shower tray with waste hole \varnothing 90 mm | Vidage p/bac douche avec \varnothing 90 mm trou \varnothing 90mm
- 55019031 Válvula sifonada para base de chuveiro c/ furo \varnothing 90mm | Valve with siphon \varnothing 90mm | Vidage avec siphon \varnothing 90mm



BAIGNOIRES | BATHTUBS | **BANHEIRAS**



5.1.1 Sistema A económico

6 injectores laterais ar + água, com regulação de direcção
Embelezadores plásticos cromados
Bomba de 680 W
Válvula de descarga automática
Comandos em plástico cromados
Garantia de 2 anos

5.1.2 Sistema A

6 injectores laterais ar + água, com regulação de direcção
Embelezadores em latão
Bomba de 680 W
Control de nível de água
Válvula de descarga automática
Comandos de latão cromados
Garantia de 3 anos

5.1.3 Sistema C

6 injectores laterais ar + água, com regulação de direcção
Embelezadores em latão
8 injectores de ar no fundo da banheira
Bomba de 900 W
Compressor de 800 W
Sensor electrónico de nível de água
Válvula de descarga automática
Comando digital ON/OFF da bomba
ON/OFF do compressor, +/- compressor
Regulador manual de admissão do ar em latão
Sistema de escoamento de águas residuais
Garantia de 3 anos

5.1.1 Economic system

6 plastic plated adjustable jets air + water
Chromed plated mirrors
Pump 680 W
Automatic pop-up waste
Chromed plated controllers
2 years guarantee against manufacture defects

5.1.2 System A

6 plastic plated adjustable jets air + water
Chromed plated mirrors
Pump 680 W
Water control level sensor
Automatic pop-up waste
Chromed plated controllers
3 years guarantee against manufacture defects

5.1.3 System C

6 plastic plated adjustable jets air + water
Chromed plated mirrors
8 water jets at bottom
Pump 900 W
Blower 800 W
Electronic water control level sensor
Automatic pop-up waste
Digital pump controller ON/OFF
ON/OFF blower; +/- blower
Manual adjust of air inlet
Water drainer
3 years guarantee against manufacture defects

5.1.1 Système Economique

6 jets plastique réglables air + eau
Miroirs Chromé
Pompe 680 W
Vidage automatique
Tableau de contrôle chromé
2 ans garantie

5.1.2 Système A

6 jets plastique réglables air + eau
Miroirs Chromé
Pompe 680 W
Contrôle de niveau eau
Vidage automatique
Tableau de contrôle chromé
3 ans garantie

5.1.3 Système C

6 jets plastique réglables air + eau
Miroirs Chromé
8 jets eau sur la base
Pompe 900 W
Blower 800 W
Sensor électronique niveau eau
Vidage automatique
Pompe digitale avec contrôle ON/OFF
ON/OFF Blower, +/- Blower
Ajusteur manuel accès air
Egout
3 ans garantie défauts de fabrication

BANHEIRAS

BATHTUBS | BAINOIRES

CE: Os sistema de hidromassagem Valadares estão de acordo com:

- directiva de Baixa Tensão 2006/96/EC
- directiva de compatibilidade electromagnética 2004/108/EC
- low voltage directive 2006/108/EC
- directive base tension 2006/108/EC
- EMC directive 2004/108/EC
- Directive CEM



Concordância comprovada pelas normas:

Whirlpool systems Valadares are in accordance to:
Système hydromassage Valadares est conforme avec:

Compatibilidade Electromagnética | Electromagnetic compatibility | Compatibilité électromagnétique
EN 55014-1:2006
EN 61000-3-2:2006
EN 61000-3-3:1995+A1:2001+A2:2005

Segurança Electrica: | electrical safety | securité électrique
EN 60335-2-60:2003+A1:2006
EN 60335-1:2002+A1:2004+A11:2004
A12:2006+A2:2006+A13:2008

Campo Magnético: | Magnetic field | champ magnétique
EN 50366:2003+A1:2006

Sesimbra



- 41725XX0 **Sesimbra** 1,60 x 0,70 m C (c/ pegas | with grips | avec poignées)
 41723XX0 **Sesimbra** 1,60 x 0,70 m A (c/ pegas | with grips | avec poignées)
 41728XX0 **Sesimbra** 1,60 x 0,70 m E (c/ pegas | with grips | avec poignées)
 51720XX0 **Sesimbra** 1,60 x 0,70 m c/VDA | with pop up waste | avec vidage
 (c/ pegas | with grips | avec poignées)
 41715XX0 **Sesimbra** 1,60 x 0,70 m C (s/ pegas | without grips | sans poignées)
 41713XX0 **Sesimbra** 1,60 x 0,70 m A (s/ pegas | without grips | sans poignées)
 41718XX0 **Sesimbra** 1,60 x 0,70 m E (s/ pegas | without grips | sans poignées)
 51710XX0 **Sesimbra** 1,60 x 0,70 m c/VDA | with pop up waste | avec vidage
 (c/ pegas | with grips | avec poignées)
 41655XX0 **Sesimbra** 1,70 x 0,70 m C (c/ pegas | with grips | avec poignées)
 41653XX0 **Sesimbra** 1,70 x 0,70 m A (c/ pegas | with grips | avec poignées)
 41658XX0 **Sesimbra** 1,70 x 0,70 m E (s/ pegas | without grips | sans poignées)
 51650XX0 **Sesimbra** 1,70 x 0,70 m c/VDA | with pop up waste | avec vidage
 (c/ pegas | with grips | avec poignées)
 41665XX0 **Sesimbra** 1,70 x 0,70 m A (s/ pegas | without grips | sans poignées)
 41663XX0 **Sesimbra** 1,70 x 0,70 m C (s/ pegas | without grips | sans poignées)
 41668XX0 **Sesimbra** 1,70 x 0,70 m E (s/ pegas | without grips | sans poignées)
 51660XX0 **Sesimbra** 1,70 x 0,70 m c/VDA | with pop up waste | avec vidage
 (c/ pegas | with grips | avec poignées)

XX - CORES DISPONÍVEIS | AVAILABLE COLOURS | COULEURS DISPONIBLES
 a) 00 | 20 (VER PÁG. 8 | SEE PAGE 8 | REGARDER PAGE 8)



Legenda | lettering | légende:

C - Sistema C / System C / Système C

A - Sistema A / System A / Système A

E - Sistema económico / Economic system / Système économique



Valadares

41965XX0	Línea 1,60 x 0,75 m C
41963XX0	Línea 1,60 x 0,75 m A
41968XX0	Línea 1,60 x 0,75 m E
51960XX0	Línea 1,60 x 0,75 m VDA with pop up waste avec vidage
41975XX0	Línea 1,70 x 0,75 m C
41973XX0	Línea 1,70 x 0,75 m A
41978XX0	Línea 1,70 x 0,75 m E
51970XX0	Línea 1,70 x 0,75 m VDA with pop up waste avec vidage
41985XX0	Línea 1,70 x 0,80 m C
41983XX0	Línea 1,70 x 0,80 m A
41988XX0	Línea 1,70 x 0,80 m E
51980XX0	Línea 1,70 x 0,80 m VDA with pop up waste avec vidage
41995XX0	Línea 1,80 x 0,80 m C
41993XX0	Línea 1,80 x 0,80 m A
41998XX0	Línea 1,80 x 0,80 m E
51990XX0	Línea 1,80 x 0,80 m VDA with pop up waste avec vidage

Com fundo anti-derrapante | Bathtubs with anti-slip base | Avec Anti-dérapage

CORES DISPONÍVEIS | AVAILABLE COLOURS | COULEURS DISPONIBLES
a) 00-20 (VER PÁG. 8 | SEE PAGE 8 | REGARDER PAGE 8)

BANHEIRAS

BATHTUBS | BAINOIRES

Legenda | lettering | légende:

C - Sistema C / System C / Système C

A - Sistema A / System A / Système A

E - Sistema económico / Economic system / Système économique

Línea

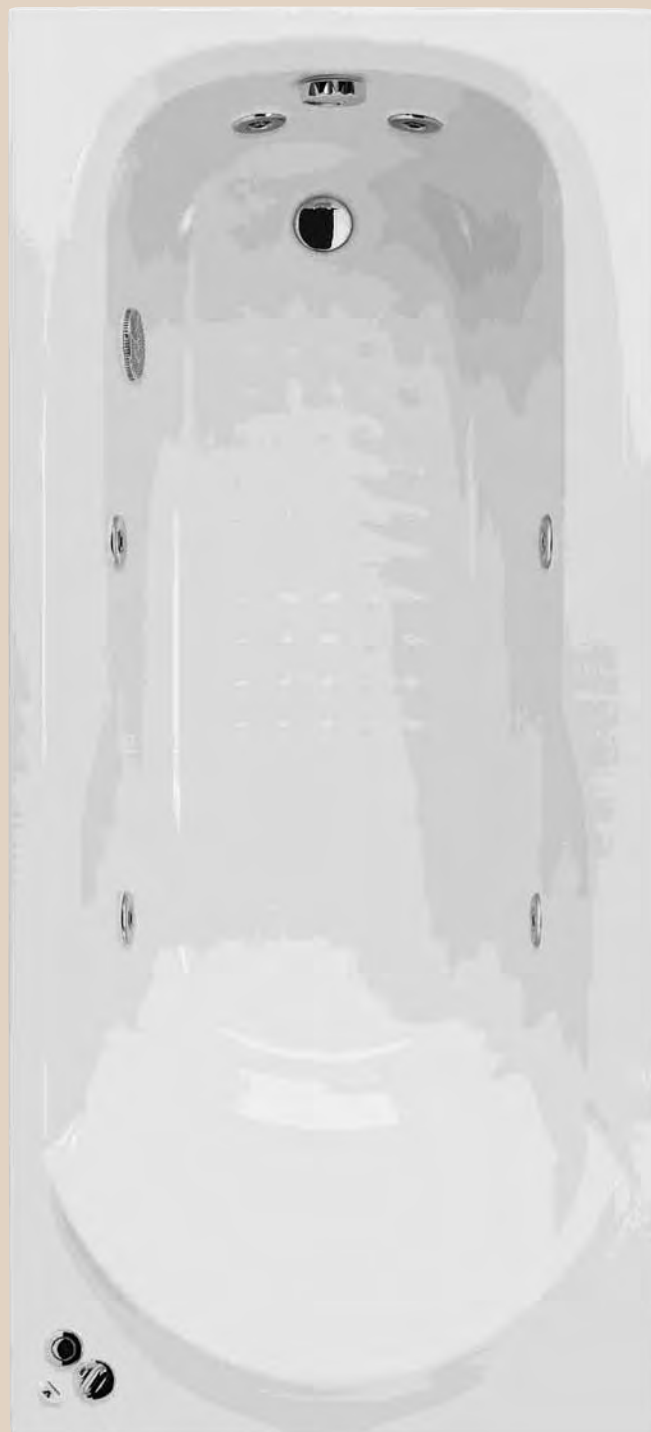

Pacific



41905XX0	Pacific 1,60 x 0,70 m C
41903XX0	Pacific 1,60 x 0,70 m A
41908XX0	Pacific 1,60 x 0,70 m E
51900XX0	Pacific 1,60 x 0,70 m VDA with pop up waste avec vidage
41915XX0	Pacific 1,70 x 0,70 m C
41913XX0	Pacific 1,70 x 0,70 m A
41918XX0	Pacific 1,70 x 0,70 m E
51910XX0	Pacific 1,70 x 0,70 m VDA with pop up waste avec vidage
41925XX0	Pacific 1,60 x 0,75 m C
41923XX0	Pacific 1,60 x 0,75 m A
41928XX0	Pacific 1,60 x 0,75 m E
51920XX0	Pacific 1,60 x 0,75 m VDA with pop up waste avec vidage
41935XX0	Pacific 1,70 x 0,75 m C
41933XX0	Pacific 1,70 x 0,75 m A
41938XX0	Pacific 1,70 x 0,75 m E
51930XX0	Pacific 1,70 x 0,75 m VDA with pop up waste avec vidage
41945XX0	Pacific 1,70 x 0,80 m C
41943XX0	Pacific 1,70 x 0,80 m A
41948XX0	Pacific 1,70 x 0,80 m E
51940XX0	Pacific 1,70 x 0,80 m VDA with pop up waste avec vidage
41955XX0	Pacific 1,80 x 0,80 m C
41953XX0	Pacific 1,80 x 0,80 m A
41958XX0	Pacific 1,80 x 0,80 m E
51950XX0	Pacific 1,80 x 0,80 m VDA with pop up waste avec vidage

XX - CORES DISPONÍVEIS | AVAILABLE COLOURS | COULEURS DISPONIBLES
a) 00 | 20 (VER PÁG. 8 | SEE PAGE 8 | REGARDER PAGE 8)

BANHEIRAS
BATHTUBS | BAIGNOIRES



41785XX0
41783XX0
41788XX0
51780XX0

Lagoa 1,70 x 0,80 m VDA C
Lagoa 1,70 x 0,80 m VDA A
Lagoa 1,70 x 0,80 m VDA E
Lagoa 1,70 x 0,80 m VDA | with pop up waste | avec vidage

Pegas em aço inox polido | Chromed plated handles |
Poignée en acier chromé

XX - CORES DISPONÍVEIS | AVAILABLE COLOURS | COULEURS DISPONIBLES
a) 00 | 20 (VER PÁG. 8 | SEE PAGE 8 | REGARDER PAGE 8)

Lagoa



BANHEIRAS
BATHTUBS | BAIGNOIRES

41875XX0
41873XX0
41878XX0
51870XX0

Gallery 1,70 x 0,80 m C
Gallery 1,70 x 0,80 m A
Gallery 1,70 x 0,80 m E
Gallery 1,70 x 0,80 m VDA | with pop up waste | avec vidage

Gallery



Com fundo anti-derrapante | Bathtubs with anti-slip base | Avec Anti-dérapage

XX - CORES DISPONÍVEIS | AVAILABLE COLOURS | COULEURS DISPONIBLES
a) 00 | 20 (VER PÁG. 8 | SEE PAGE 8 | REGARDER PAGE 8)

BANHEIRAS
BATHTUBS | BAINOIRES



41795XX0 **Foz** 1,80 x 0,80 m C
41793XX0 **Foz** 1,80 x 0,80 m A
41798XX0 **Foz** 1,80 x 0,80 m E
51790XX0 **Foz** 1,80 x 0,80 m VDA | with pop up waste | avec vidage

Com fundo anti-derrapante | Bathtubs with anti-slip base | Avec Anti-dérápaga

XX - CORES DISPONÍVEIS | AVAILABLE COLOURS | COULEURS DISPONIBLES
a) 00 | 20 (VER PÁG. 8 | SEE PAGE 8 | REGARDER PAGE 8)

Foz



BANHEIRAS
BATHTUBS | BAIGNOIRES

41885XX0	Atlantic 1,90 x 0,90 m C
41883XX0	Atlantic 1,90 x 0,90 m A
51880XX0	Atlantic 1,90 x 0,90 m VDA with pop up waste avec vidage
41895XX0	Atlantic 2,00 x 1,00 m C
41893XX0	Atlantic 2,00 x 1,00 m A
51890XX0	Atlantic 2,00 x 1,00 m VDA with pop up waste avec vidage

Atlantic



XX - CORES DISPONÍVEIS | AVAILABLE COLOURS | COULEURS DISPONIBLES
a) 00 | 20 (VER PÁG. 8 | SEE PAGE 8 | REGARDER PAGE 8)



COMPLEMENTOS BANHEIRAS DE HIDROMASSAGEM
ACCESSORIES FOR WIRLPOOL BATHTUBS
ACCESSOIRES POR BAGNOIRES HIDROMASSAGE

- 55015001 Injetor água/ar em latão (standard)
 Jet air/ water chromed plated (standard)
 Jets eau / air en laiton (standard)
- 55015011 Injetor água/ar rotativo e regulável em latão(opcional)
 Jet air/ water totative and adjustable chromed plated (opcional)
 Jet eau/air rotatif et réglable (option)
- 55017021 Válvula cromada para banheira
 Pop-up waste chromed plated for bathtub
 Vidage chromé pour baignoire
- 55042041 Pega (par) para banheira Sesimbra
 Handles (set) for Sesimbra
 Poigne (pair) pour baignoire Sesimbra
- 55106000 Disjuntor diferencial 2 x 16 A, 30 MA
 Circuit breaker 2 x 16 A, 30 MA
 Disjoncteur différentiel 2 x 16 A, 30 MA
- 55107000 Caixa estanque p/ alojamento do disjuntor diferencial
 Box for circuit braker
 Boîte stagnant pour disjoncteur différentiel

XX - CORES DISPONÍVEIS | AVAILABLE COLOURS | COULEURS DISPONIBLES
 a) 00 | 20 (VER PÁG. 8 | SEE PAGE 8 | REGARDER PAGE 8)

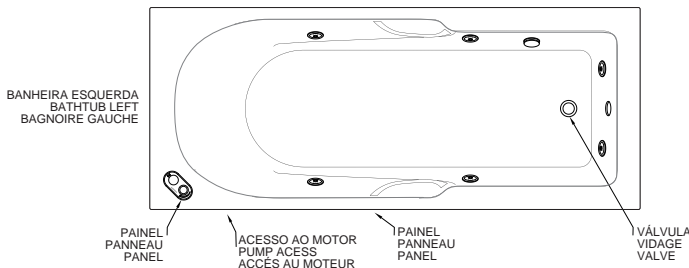
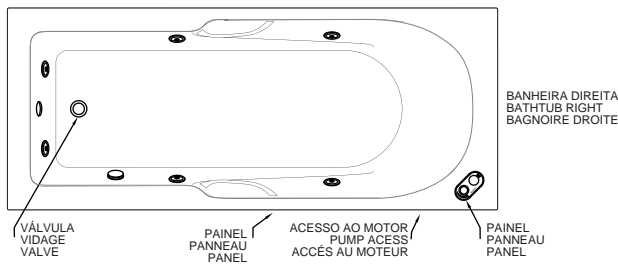

PAINÉIS RECTANGULARES LATERAIS ACRÍLICOS
RECTANGULAR FRONT PANELS FOR BATHTUBS
PANNEAU FRONTAL POUR BAGNOIRES

- 50441XX27 Painel Lateral 200 x 0,5 m p/ banheira
 Front panel | Panneau Frontal pour baignoires
- 50441XX26 Painel Lateral 1,90 x 0,50 m p/ banheira
 Front panel | Panneau Frontal pour baignoires
- 50441XX5 Painel Lateral 1,80 x 0,50 m | Front panel | Panneau Frontal pour baignoires
- 50441XX2 Painel Lateral 1,70 x 0,50 m | Front panel | Panneau Frontal pour baignoires
- 50441XX3 Painel Lateral 1,60 x 0,50 m | Front panel | Panneau Frontal pour baignoires
- 55119000 Kit fixação de painel | Fixation kit for panel | Kit fixer pour panneau

XX - CORES DISPONÍVEIS | AVAILABLE COLOURS | COULEURS DISPONIBLES
 a) 00 | 20 (VER PÁG. 8 | SEE PAGE 8 | REGARDER PAGE 8)

PAINÉIS RECTANGULARES TOPO ACRÍLICOS
SIDE PANELS | PANNEAU LATERAL

- 50441XX302 Painel topo p/banheira esq.
 Frontal panel left| Panneau Lateral gauche 1,00 x 0,50 m
- 50441XX301 Painel topo p/banheira dir.
 Frontal panel right| Panneau Lateral droite 1,00 x 0,50 m
- 50441XX312 Painel topo p/banheira esq.
 Frontal panel left| Panneau Lateral gauche 0,90 x 0,50 m
- 50441XX311 Painel topo p/banheira dir.
 Frontal panel right| Panneau Lateral droite 0,90 x 0,50 m
- 50441XX42 Painel topo p/banheira esq.
 Frontal panel left| Panneau Lateral gauche 0,80 x 0,50 m
- 50441XX41 Painel topo p/banheira dir.
 Frontal panel right| Panneau Lateral droite 0,80 x 0,50 m
- 50441XX322 Painel topo p/banheira esq.
 Frontal panel left| Panneau Lateral gauche 0,75 x 0,50 m
- 50441XX321 Painel topo p/banheira dir.
 Frontal panel right| Panneau Lateral droite 0,75 x 0,50 m
- 50441XX92 Painel topo p/banheira esq.
 Frontal panel left| Panneau Lateral gauche 0,70 x 0,50 m
- 50441XX91 Painel topo p/banheira dir.
 Frontal panel right| Panneau Lateral droite 0,70 x 0,50 m

BANHEIRAS
BATHTUBS | BAGNOIRES



Painel Direito
 Panel right | Panneau droite



Painel Esquerdo
 Panel left | Panneau gauche

XX - CORES DISPONÍVEIS | AVAILABLE COLOURS | COULEURS DISPONIBLES
 a) 00 | 20 (VER PÁG. 8 | SEE PAGE 8 | REGARDER PAGE 8)

Nueva Europa



52051XX0	Nueva Europa 1,70 x 0,70 m
52050XX0	Nueva Europa 1,60 x 0,70 m
52049XX0	Nueva Europa 1,50 x 0,70 m
52048XX0	Nueva Europa 1,40 x 0,70 m
52047XX0	Nueva Europa 1,30 x 0,70 m
52046XX0	Nueva Europa 1,20 x 0,70 m
52045XX0	Nueva Europa 1,00 x 0,70 m

Chapa c/ espessura de 1,6 mm. Espessura total c/ esmalte de 2 mm.
Steel 1,6 thickness - total steel + enamel 2 mm.
Acier avec 1,6 mm épaisseur. Epaisseur total avec émail 2 mm.

Com fundo anti-derrapante | Bathtubs with anti-slip base | Avec Anti-dérapage

Código a terminar em 1- Cromado; Código a terminar em 2- Dourado
Code ending in 1- Chromed; Code ending in 2- Golden
Code terminer par 1 - Chromé; Code terminer par 2 - Doré

XX - CORES DISPONÍVEIS | AVAILABLE COLOURS | COULEURS DISPONIBLES
a) 00 | 20 (VER PÁG. 8 | SEE PAGE 8 | REGARDER PAGE 8)

BANHEIRAS
BATHTUBS | BAIGNOIRES



Valadares

- 52058XX0 **América** 1,70 x 0,70 m c/ pegas cromadas
with chromed handles | avec poignéé chromé
- 52057XX0 **América** 1,60 x 0,70 m c/ pegas cromadas
with chromed handles | avec poignéé chromé
- 52056XX0 **América** 1,50 x 0,70 m c/ pegas cromadas
with chromed handles | avec poignéé chromé
- 52055XX0 **América** 1,40 x 0,70 m c/ pegas cromadas
with chromed handles | avec poignéé chromé

Com fundo anti-derrapante | Bathtubs with anti-slip base | Avec Anti-dérapage

Chapa c/ espessura de 1,6 mm. Espessura total c/ esmalte de 2 mm.
Steel 1,6 thickness - total steel + enamel 2 mm.
Acier avec 1,6 mm épaisseur. Epaisseur total avec émail 2 mm.

XX - CORES DISPONÍVEIS | AVAILABLE COLOURS | COULEURS DISPONIBLES
a) 00 | 20 (VER PÁG. 8 | SEE PAGE 8 | REGARDER PAGE 8)

América



BANHEIRAS
BATHTUBS | BAIGNOIRES

Dafne

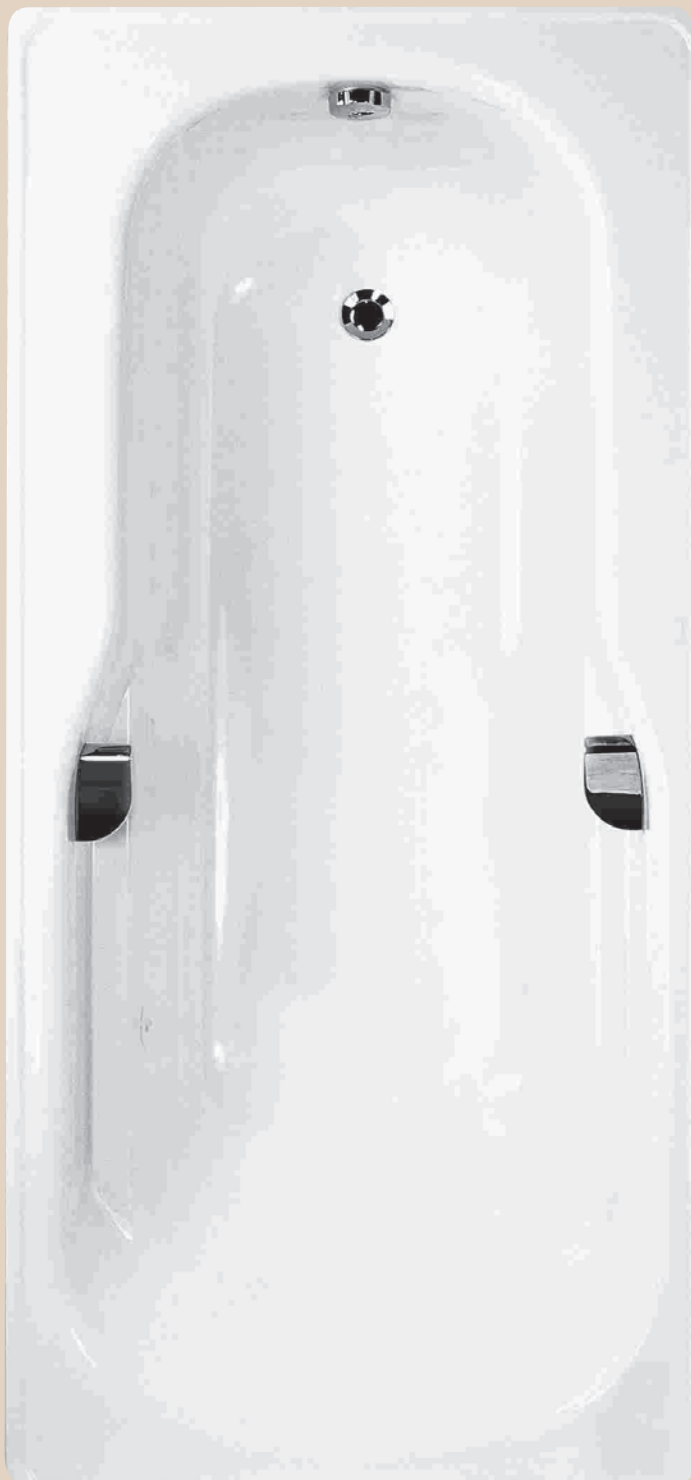

- 52061XX0 **Dafne** 1,70 x 0,75 m c/ pegas cromadas
with chromed handles | avec poignéé chromé
- 52060XX0 **Dafne** 1,60 x 0,75 m c/ pegas cromadas
with chromed handles | avec poignéé chromé

Com fundo anti-derrapante | Bathtubs with anti-slip base | Avec Anti-dérapage

Chapa c/ espessura de 1,6 mm. Espessura total c/ esmalte de 2 mm.
Steel 1,6 thickness - total steel + enamel 2 mm.
Acier avec 1,6 mm épaisseur. Epaisseur total avec émail 2 mm.

XX - CORES DISPONÍVEIS | AVAILABLE COLOURS | COULEURS DISPONIBLES
a) 00 | 20 (VER PÁG. 8 | SEE PAGE 8 | REGARDER PAGE 8)

BANHEIRAS

BATHTUBS | BAIGNOIRES

5.9 COMPLEMENTOS BANHEIRAS ESMALTADAS | ACCESSORIES FOR ENAMELLED STEEL BATHTUBS |
COMPLÉMENTS BAGNOIRES ACER

- 55045100 Conjunto de pés para banheira (adaptáveis a todas as banheiras do subcapítulo 5.9)
Feet (set) for bathtub (Adjustable to all bathtubs chapter 5.9)
Ensemble pieds pour baignoire (adaptabilité toute baignoires chapitre 5.9)
- 55017021 Válvula p/ banheira, descarga automática
Automatic pop-up waste
Vidage automatique pour baignoire

ROBINETTERIE DE SALLE DE BAIN | FAUCETS | TORNEIRAS



TORNEIRAS

FAUCETS | ROBINETTERIE DE SALLE DE BAIN

- | | | |
|----------|----|--|
| 50699002 | 01 | Monocomando de lavatório cromado BasinMixer Mitigeur de lavabo |
| 50699402 | 02 | Extensor lavatório alto cromado Extension for washbasin mixer Extention pour mitigeur de lavabo |
| 50699102 | 03 | Monocomando de bidê cromado Bidet mixer chromed Mitigeur chromé de lavabo |
| 50699152 | 04 | Misturadora de lavatório de parade cromado Wall mounted basin mixer chromed Mitigeur chromé de lavabo d'encastrer |
| 50699202 | 05 | Monocomando de banheira cromado Bathtub mixer chromed Mitigeur de baignoire |
| 50699252 | 06 | Monocomando de base de chuveiro cromado Shower mixer chromed Mitigeur de douche |
| 50699302 | 07 | Misturadora de encastrar de banheira cromado Wall mounted bathtub mixer chromed Mitigeur baignoire d'encastrer |
| 50699352 | 08 | Misturadora de encastrar de base de chuveiro cromado Wall mounted shower mixer chromed Mitigeur chromé douché |
| 50699012 | 09 | Monocomando de lavatório cromado/preto Basin mixer chromed/black Mitigeur noir/chromé pour lavabo |
| 50699112 | 10 | Monocomando de bidê cromado/preto Bidet mixer chromed/black Mitigeur noir/chromé pour bidet |
| 50699162 | 11 | Misturadora de lavatório de parede cromado/preto Wall mounted basin mixer chromed/black Mitigeur d'encastrer chromé/noir pour lavabo |
| 50699212 | 12 | Monocomando de banheira cromado/preto Bathtub mixer chromed/black Mitigeur noir/chromé de baignoire |

X - Cores

-0-
Cromado
Chromed
Chromé

-1-
Cromo / Preto
Chromed / Black
Chromé / Noir

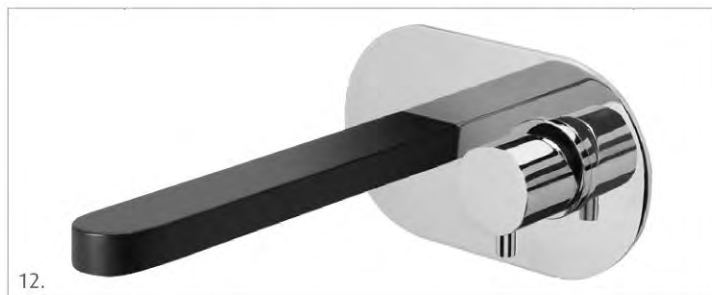
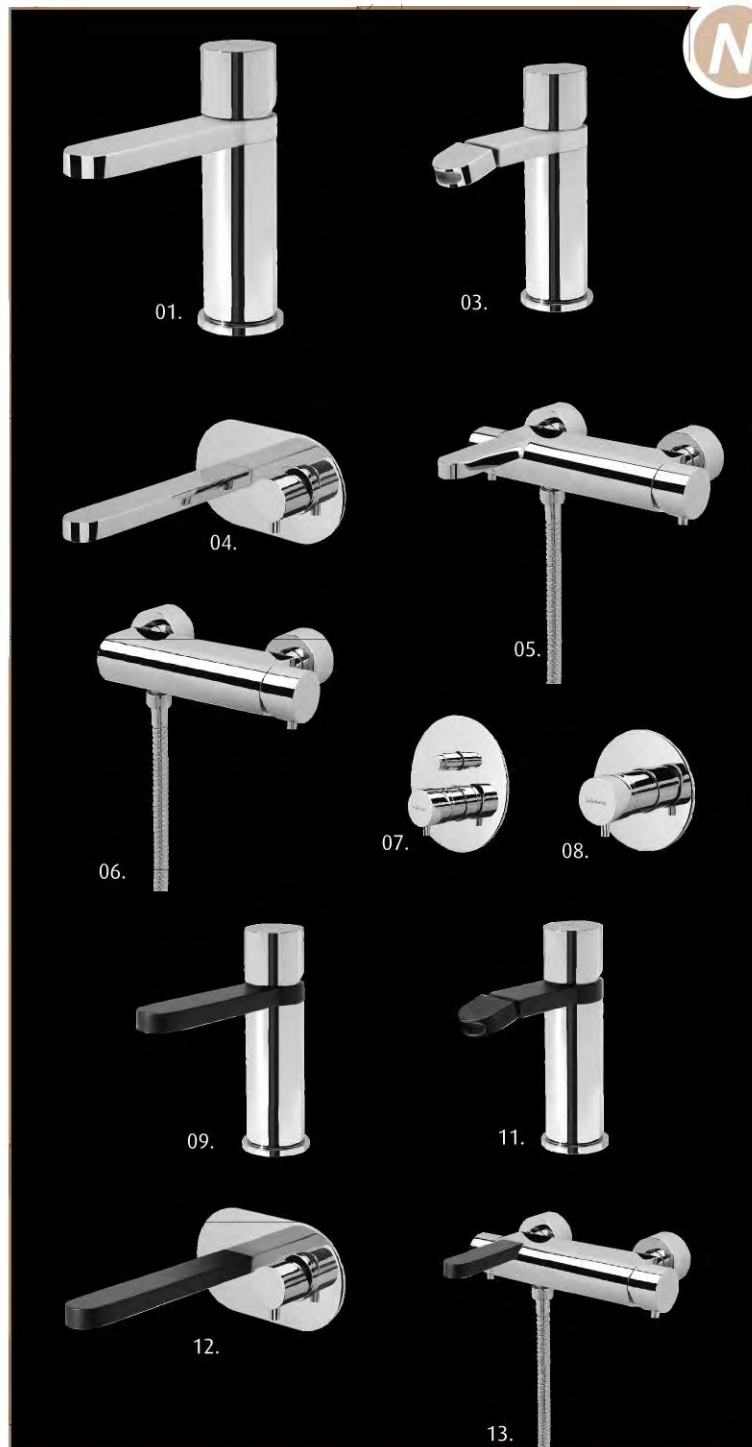

» A harmonia e simplicidade de formas associada à alta tecnologia de fabrico e às soluções amigas do ambiente.
Os monocomandos de lavatório e de bidê são equipados com perlares de baixo caudal (7 litros / minuto máximo a 4 bar de pressão), permitindo uma redução de consumo de água de cerca de 50%.
Garantia de cinco anos contra defeitos de fabrico.

» The harmony and simplicity of forms associated with high technology and manufacturing solutions to the environment.
The basin mixers and bidet are equipped with low - flow aerator (7 liters /minute up to 4 bars of pressure), allowing a reduction of water consumption of around 50%.
5 Year warranty against manufacturing defects.

» L'harmonie et la simplicité des formulaires liés à la haute technologie et des solutions de fabrication pour l'environnement.
Mono-commandes lavabo et bidet sont équipés avec un débit très bas aérateur (7 litres / minute jusqu'à 4 bars de pression), permettant une réduction de la consommation d'eau d'environ 50%.
5 ans de garantie contre les défauts de fabrication.



-0- Cromado Chromed Chromé	-1- Branco White Blanc	-2- Antracite mate Anthracite Mate Anthracite Mate	-3- Preto Black Noir	-4- Cereja Red Cerise	-5- Tangerina Orange Mandarine	-6- Verde Green Vert
----------------------------------	------------------------------	--	----------------------------	-----------------------------	--------------------------------------	----------------------------

X - Cores
Colours
Couleurs

TORNEIRAS

FAUCETS | ROBINETTERIE DE SALLE DE BAIN

- 506190X2 01 Monocomando lavatório/ bidé | Basin/ Bidet mixer | Mitigeur de lavabo(1) (3)
 50697062 02 Extensor de lavatório alto | Extension for basin mixer | Extension pour mitigeur de lavabo (2)
 506197X2 03 Monocomando de lavatório de parede | Wall mounted basin | Mitigeur de lavabo d'encastrer
 506194X2 04 Monocomando banheira | Bathtub mixer | Mitigeur de baignoire (1)
 506192X2 05 Monocomando base de chuveiro | Shower mixer | Mitigeur de douche (1)
 50619502 06 Monocomando de banca com bica rotativa | Sink mixer with swivel spout | Mitigeur de cuisine avec bec orientable
 50619552 07 Monocomando de banca com bica rotativa e retráctil | Sink mixer with swivel spout and pull-out handshower | Mitigeur de cuisine avec bec orientable et douchette extractible
 50619562 08 Misturadora de base de chuveiro de encastrar termostática | Thermostatic wall mounted shower mixer | Mitigeur thermostatique de douche d'encastrer
 50646312 09 Misturadora de base de chuveiro de encastrar | Wall mounted shower mixer | Mitigeur de douche sur d'encastrer
 50619582 10 Misturadora de banheira de encastrar termostática | Thermostatic wall mounted bathtub mixer | Mitigeur thermostatique de baignoire d'encastrer
 50646342 11 Misturadora de banheira de encastrar | Wall mounted bathtub mixer | Mitigeur de baignoire d'encastrer
 50619602 12 Misturadora de encastrar termostática c/ distribuidor 3 vias | Thermostatic wall mounted mixer with 3 ways | Mitigeur de baignoire/ douche thermostatique d'encastrer
 50619612 13 Misturadora de encastrar com distribuidor 3 vias | Wall mounted mixer with 3 ways | Mitigeur de baignoire / douche d'encastrer 3 sorties
 50619622 14 Bica de banheira de encastrar | Bathtub spout | Bec baignoire
 55173010 15 Tomada de água com suporte de chuveiro | Inlay water outlet for shower hole | Point eau pour douchette
 50697052 16 Chuveiro manual | Handshower | Douchette main
 50617022 17 Bicha de chuveiro | Shower hose | Tuyau pour douchette
 606198X2 Conjunto de 7 placas(cores) para monocomando Lusíada (Aplicável nos monocomando bidé e banheira) | Set of 7 plates (colors) for the mixer basin bidet and bathtub | Série de 7cartes (couleurs) pour mitigeur de lavabo, bidet et baignoire



04.



08.



05.

TORNEIRAS

FAUCETS | ROBINETTERIE DE SALLE DE BAIN

- 50627002 01 Monocomando de lavatório | Basin mixer | Mitigeur de lavabo (1)
- 50627012 02 Monocomando de lavatório alto | Basin mixer | Mitigeur de lavabo (2)
- 50627072 03 Monocomando de lavatório de parede | Wall mounted basin mixer | Mitigeur de lavabo d'encastrer (1)
- 50627032 04 Monocomando de bidé | Bidet mixer | Mitigeur de bidet
- 50627052 05 Monocomando de banheira | Bath tub mixer | Mitigeur de baignoire
- 50627062 06 Monocomando de base de chuveiro | Shower mixer | Mitigeur de douchette
- 50627092 07 Monocomando de banca com bica rotativa | Sink mixer with swivel spout | Mitigeur de cuisine avec bec orientable
- 50627102 08 Misturadora de base de chuveiro de encastrar termostática | Thermostatic wall mounted shower mixer | Mitigeur de douchette thermostatique d'encastrer
- 50627112 09 Misturadora de base de chuveiro de encastrar | Wall mounted shower mixer | Mitigeur de douchette d'encastrer
- 50627122 10 Misturadora de banheira de encastrar termostática | Thermostatic wall mounted shower/ bath mixer | Mitigeur de baignoire/ douchette thermostatique d'encastrer
- 50627132 11 Misturadora de banheira de encastrar | Wall mounted shower/ bath mixer | Mitigeur de baignoire/ douchette d'encastrer
- 50627142 12 Misturadora de encastrar termostática com distribuidor 3 vias | Thermostatic wall mounted bathtub mixer with 3 ways | Mitigeur de baignoire/ douchette thermostatique d'encastrer 3 sorties
- 50627152 13 Misturadora de encastrar com distribuidor 3 vias | Wall mounted bathtub mixer with 3 ways | Mitigeur de baignoire / douche d'encastrer 3 sorties
- 50627162 14 Bica de banheira de encastrar | Bath tub spout | Bec baignoire
- 55173010 15 Tomada de água com suporte de chuveiro | Inlay water outlet for shower hole | Douchette main
- 50697052 16 Chuveiro manual | Handshower | Bec douchette
- 50617022 17 Bicha de chuveiro | Shower spout | Tuyau pour douchette

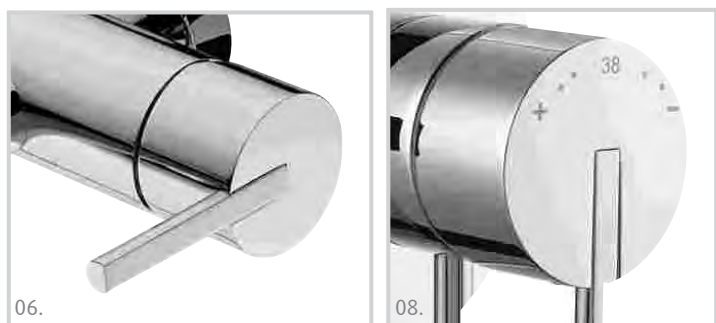
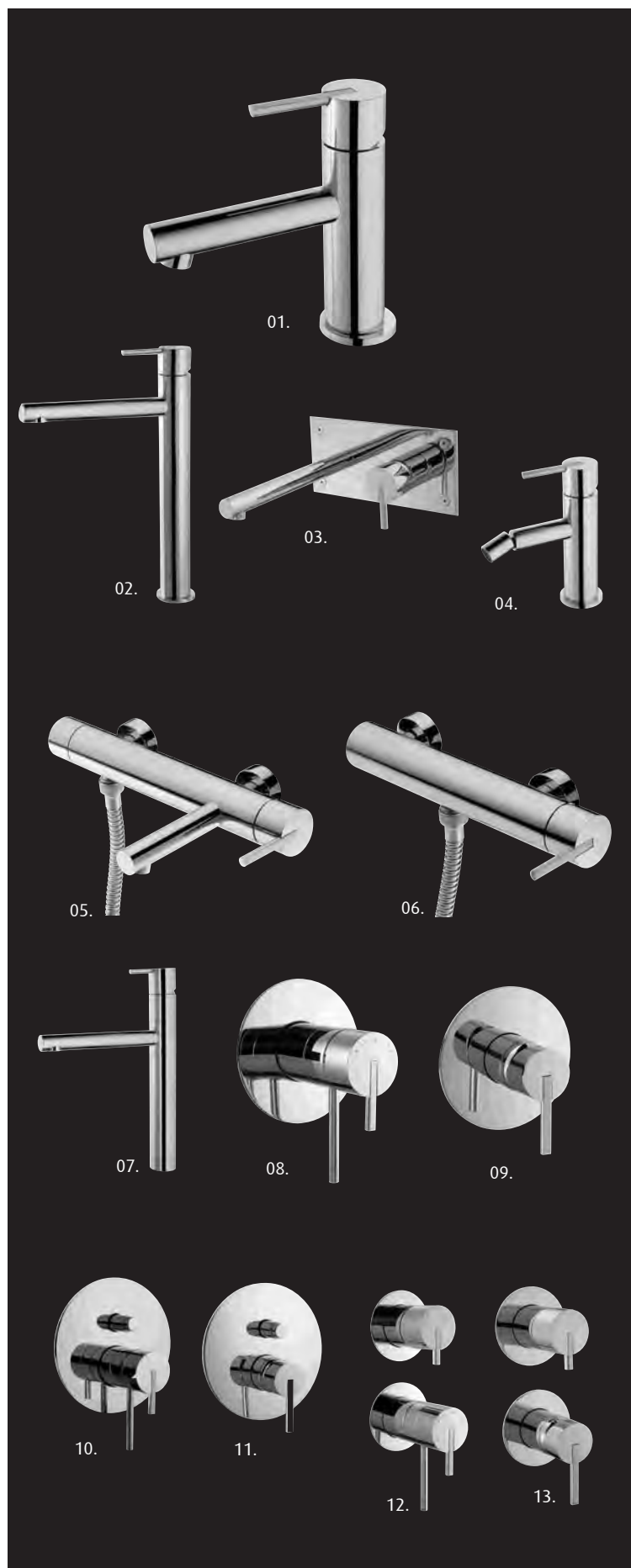

(2) Para instalar com a peça 50697072 | To install with piece 50697072 | D'installer la piece 50697072



TORNEIRAS

FAUCETS | ROBINETTERIE DE SALLE DE BAIN

- | | |
|----------|---|
| 50695012 | 01 Monocomando lavatório válvula clic clac Basin mixer with clic clac pop up Mitigeur de lavabo avec vidage clic clac |
| 50695332 | 02 Monocomando lavatório alto válvula clic clac Basin mixer for high level basin with clic clac pop up Mitigeur de lavabo allongé avec vidage clic clac |
| 50695372 | 03 Monocomando lavatório médio válvula clic clac Basin mixer for medium basin with clic clac pop up Mitigeur de lavabo moyen avec vidage clic clac |
| 50695412 | 04 Monocomando de lavatório de parede Wall mounted basin mixer Mitigeur de lavabo d'encastrer |
| 50695032 | 05 Monocomando bidé válvula clic clac Bidet mixer with clic clac pop up Mitigeur de bidet |
| 50695052 | 06 Monocomando banheira Bathtub mixer Mitigeur de baignoire / douche |
| 50695062 | 07 Monocomando base de chuveiro Showertray mixer Mitigeur de douche avec douchete |
| 50695382 | 08 Rampa de chuveiro Shower rail Barre de douche |
| 50695392 | 09 Monocomando de banca rotativa Kitchen mixer Mitigeur de cousine |
| 50695112 | 10 Misturadora de banheira de encastrar Wall mounted shower/ bath mixer Mitigeur de baignoire/ douchette d'encastrer |
| 50695122 | 11 Misturadora de base de chuveiro de encastrar Wall mounted shower mixer Mitigeur de douchette d'encastrer |

Monocomandos com cartucho de 25mm | Garantia de 5 anos para defeitos de fabrico
 Mixers with 25mm ceramic disk | 5 years guarantee against manufacturing defects
 Mitigeurs avec plateau caramique 25mm | Garantie 5 ans contre défaut de fabrication

TORNEIRAS

FAUCETS | ROBINETTERIE DE SALLE DE BAIN

- | | |
|----------|--|
| 50645022 | 01. Monocomando de lavatório c/ válvula clic-clac Basin mixer with pop up Mitigeur de Lavabo avec vidage |
| 50645352 | 02. Monocomando de lavatório médio c/ válvula clic-clac Single lever for washbasin medium with pop up Mitigeur de Lavabo moyen avec vidage |
| 50645342 | 03. Monocomando de lavatório alto c/ válvula clic-clac Basin mixer for high level washbasin with pop up Mitigeur de lavabo allongé avec vidage |
| 50645042 | 04. Monocomando de bidé c/ válvula clic-clac Bidet mixer with pop up Mitigeur de Bidet avec vidage |
| 50645082 | 05. Monocomando de banheira Bathtub mixer Mitigeur Bain/Douche avec douchette |
| 50645072 | 06. Monocomando de base de chuveiro Shower mixer Mitigeur douche avec douchette |
| 50646262 | 07. Misturadora de banca c/ bica giratória Kitchen mixer Mitigeur de cuisine avec bec orientable |
| 50646472 | 08. Misturadora lava-louça profissional Kitchen mixer Mitigeur de cuisine |
| 50646012 | 09. Misturadora de lavatório de parede Washbasin wall mixer Mélangeur 3 trous |
| 50679010 | 10. Passador de 1/2" p/ monocomando Angle valve 1/2" for single lever Robinette a encastrer 1/2 |
| 50679020 | 11. Passador de 3/4" p/ monocomando Angle valve 3/4" for single lever Robinette a encastrer 3/4 |
| 50646312 | 12. Misturadora base de chuveiro de encastrar Mixer for shower tray inlay Mitigeur Douche encastré |
| 50646342 | 13. Misturadora de banheira de encastrar Mixer for bathtub inlay Mitigeur Bain/ Douche encastré |
| 50649002 | 14. Chuveiro c/ haste Shower with support Douchete encastré |
| 50649012 | 15. Bica de banheira Bathtub spout Bec baignoire |
| 50649022 | 16. Torneira de esquadria 1/2" x 3/8" Angle valve 1/2" x 3/8" Robinet d'équerre 1/2 x 3/8 |
| 50678002 | 17. Rampa chuveiro Shower rail Barre de Douche |
| 50697012 | 18. Chuveiro Manual Handy shower tray Douchete encastré |
| 50617012 | 19. Bicha p/ chuveiro Shower Arm and Rose Arm and Rose four shower |
| 50697002 | 20. Suporte p/ chuveiro Shower support Support p/douchette |
| 55173000 | 21. Tomada de água para chuveiro manual Inlay mixer for shower tray Robinet pour douche |
| 50649102 | 22. Torneira temporizada de lavatório Timer tap for washbasin Robinet poussoir p/ lavabo |
| 50649112 | 23. Torneira temporizada de urinál Timer tap for urinal Robinet poussoir p/ urinoir |
| 50649122 | 24. Torneira temporizada de chuveiro encastrada Timer tap for shower (inlay) Robinet poussoir p/douchette |
| 50667062 | 25. Torneira temporizada de parede para lavatório Timer tap washbasin Robinet poussoir pour lavabo |
| 50628102 | 26. Torneira de lavatório de coluna Pilar tap washbasin Mitigeur lavabo colonne |

» Os monocomandos de lavatório e de bidé são equipados com perlatores de baixo caudal (7 litros / minuto máximo a 4 bar de pressão), permitindo uma redução de consumo de água de cerca de 50%.

Garantia de cinco anos contra defeitos de fabrico.

» The basin mixers and bidet are equipped with low - flow aerator (7 liters /minute up to 4 bars of pressure), allowing a reduction of water consumption of around 50%.

5 Year warranty against manufacturing defects.

» Les robinets mitigeurs pour lavabo et bidet sont équipés d'aérateur à faible débit (7 litres / minute au maximum à 4 bars de pression), permettant une réduction de la consommation d'eau d'environ 50%.

5 ans de garantie contre les défauts de fabrication.



Monocomandos com cartucho de 35mm | Garantia de 5 anos para defeitos de fabrico
 Mixers with 35mm ceramic disk | 5 years guarantee against manufacturing defects
 Mitigeurs avec plateau caramique 35mm | Garantie 5 ans contre défaut de fabrication

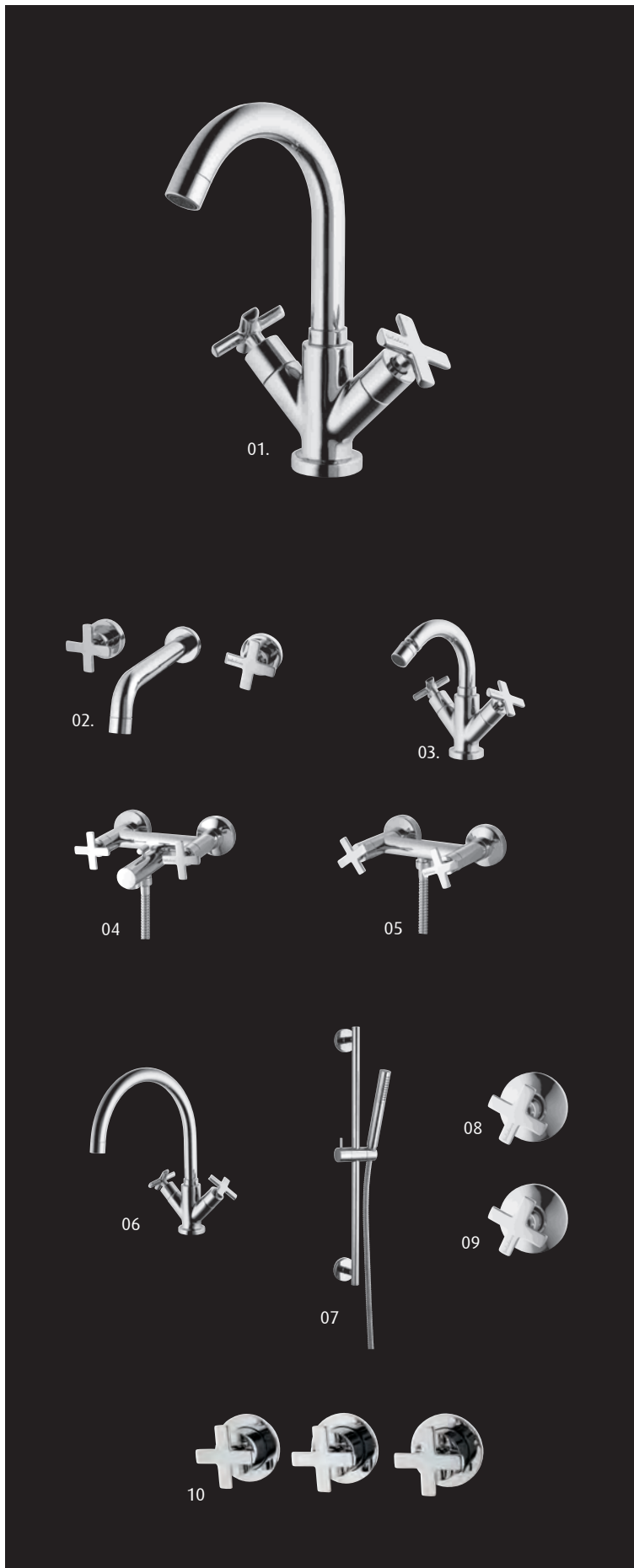

TORNEIRAS

FAUCETS | ROBINETTERIE DE SALLE DE BAIN

- 50696002 01. Misturadora de lavatório c/ vda | Basin mixer with pop up waste | Mitigeur de lavabo avec vidage
- 50696412 02. Misturadora de parede 3 furos c/ válvula clic-clac | 3 tap holes basin mixer with valve | Mélangeur 3 trous avec vidage
- 50696022 03. Misturadora de bidé c/ vda | Bidet mixer with pop up waste | Mitigeur de bidet avec vidage
- 50696032 04. Misturadora de banheira | Bathtub mixer | Mitigeur de baignoire/douche
- 50696042 05. Misturadora de base de chuveiro | Shower mixer | Mitigeur de douche avec douchette
- 50696052 06. Misturadora de banca rotativa | Kitchen mixer | Mitigeur de cuisine
- 50695382 07. Rampa de chuveiro | Shower mixer | Barre de douche
- 50696072 08. Passador 1/2" | Angle tap 1/2" | Robinet d'équerre 1/2"
- 50696082 09. Passador 3/4" | Angle tap 3/4" | Robinet d'équerre 3/4"
- 50696102 10. Misturadora de banheira de encastrar | Wall mounted bathtub mixer | Mitigeur de baignoire d'encastrear

Garantia de 5 anos para defeitos de fabrico
 5 years guarantee against manufacturing defects
 Garantie 5 ans contre défaut de fabrication

TORNEIRAS

FAUCETS | ROBINETTERIE DE SALLE DE BAIN

- | | |
|----------|--|
| 50635012 | 01. Monocomando para lavatório c/VDA Basin mixer with pop-up waste Mitigeur lavabo avec vidage |
| 50635022 | Monocomando para lavatório s/VDA Basin mixer without pop-up waste Mitigeur lavabo s/ vidage |
| 50635032 | 02. Monocomando para bidé c/VDA Bidet mixer with pop-up waste Mitigeur bidet avec vidage |
| 50635042 | Monocomando para bidé s/VDA Bidet mixer without pop-up waste Mitigeur bidet s/ vidage |
| 50635052 | 03. Monocomando para banheira Wall mounted bath/shower mixer Mitigeur bain douche avec douchette |
| 50635062 | 04. Monocomando para base de chuveiro Wall mounted shower mixer Mitigeur douche |
| 50635262 | 05. Monocomando para banca c/ bica rotativa Kitchen mixer Mitigeur cuisine avec bec orientable |

Complementos | Complements | Complement:

- | | |
|----------|--|
| 50654002 | Rampa de chuveiro Slide bar for hand spray Barre douche |
| 50656022 | Válvula de esquadria 1/2" x 3/4" Angle valve 1/2" x 3/4" Robinet d'equerre 1/2" x 3/4" |
| 50656012 | Válvula de esquadria 1/2" x 1/2" Angle valve 1/2" x 1/2" Robinet d'equerre 1/2" x 1/2" |
| 50656032 | Válvula de esquadria 1/2" x 3/8" Angle valve 1/2" x 3/8" Robinet d'equerre 1/2" x 3/8" |
| 50679010 | Passador de 1/2" Angle valve 1/2" Robinet à encastre de 1/2" |
| 50679020 | Passador de 3/4" Angle valve 3/4" Robinet à encastre de 3/4" |

Monocomandos com cartucho de 40mm | Garantia de 5 anos para defeitos de fabrico
 Mixers with 40mm ceramic disk | 5 years guarantee against manufacturing defects
 Mitigeurs avec plateau caramique 40mm | Garantie 5 ans contre défaut de fabrication

- | | |
|----------|--|
| 50636022 | 01. Monocomando para lavatório S/VDA Basin monobloc Mitigeur lavabo s/ vidage |
| 50636042 | 02. Monocomando para bidé S/VD A Bidet monobloc Mitigeur bidet s/ vidage |
| 50636052 | 03. Monocomando para banheira Wall mounted bath/shower mixer Mitigeur bain douche avec douchette |
| 50636062 | 04. Monocomando para base de chuveiro Wall mounted shower mixer Mitigeur douche |
| 50635262 | 05. Misturadora de banca c/ bica rotativa Kitchen mixer Mitigeur cuisine avec bec orientable |

Complementos | Complements | Complement:

- | | |
|----------|--|
| 50654002 | Rampa de chuveiro Slide bar for hand spray Barre douche |
| 50656022 | Válvula de esquadria 1/2" x 3/4" Angle valve 1/2" x 3/4" Robinet d'equerre 1/2" x 3/4" |
| 50656012 | Válvula de esquadria 1/2" x 1/2" Angle valve 1/2" x 1/2" Robinet d'equerre 1/2" x 1/2" |
| 50656032 | Válvula de esquadria 1/2" x 3/8" Angle valve 1/2" x 3/8" Robinet d'equerre 1/2" x 3/8" |
| 50679010 | Passador de 1/2" Angle valve 1/2" Robinet à encastre de 1/2" |
| 50679020 | Passador de 3/4" Angle valve 3/4" Robinet à encastre de 3/4" |

Monocomandos com cartucho de 35mm | Garantia de 2 anos para defeitos de fabrico
 Mixers with 35mm ceramic disk | 2 years guarantee against manufacturing defects
 Mitigeurs avec plateau caramique 35mm | Garantie 2 ans contre défaut de fabrication



DREAM



50602002 Torneira capacitiva Dream | Capacitive tap "Dream" | Capacitif robinet "Dream"
 50602012 Misturadora capacitiva Dream | Capacitive mixer "Dream" | Capacitif mitigeur "Dream"

Estas torneiras são accionadas pelo aproximar das mãos. Ao afastá-las param de imediato. Têm cinco níveis de sensibilidade, definindo a distância de aproximação. Detectam a aproximação das mãos em qualquer ponto da torneira, não sendo necessário aproximá-las de um qualquer sensor, como habitualmente acontece. Funcionam com uma pilha de lítio de 6V. O sistema de controle é posicionado fora da torneira, sob o lavatório ou dentro do respectivo móvel.

These faucets are activated by the approach of the hands, getting away stop them immediately. They have five levels of sensitivity, defining the approach distance. Detect the approach of the hand anywhere on the faucet, eliminating them from approaching a sensor, as usually happens. Work with a 6V lithium battery. The control system is positioned outside the faucet under the sink or inside their furniture.

Ces robinets sont activés par l'approche des mains, loin de les arrêter immédiatement. Ils ont cinq niveaux de sensibilité, de définir la distance d'approche. Détecter l'approche de la main n'importe où sur le robinet, les éliminer de l'approche d'un capteur, comme d'habitude se passe. Travailler avec une pile au lithium 6V. Le système de contrôle est positionné à l'extérieur du robinet sous l'évier ou à l'intérieur de leur meuble.

TEMPORIZADAS



50667082 01. Misturadora de lavatório temporizada Assi 
 50649102 02. Torneira temporizada de lavatório Assi | Timer mixer basin Assi | Timer robinet lavabo Assi

TORNEIRAS

FAUCETS | ROBINETTERIE DE SALLE DE BAIN

- 50667062 | 03. Torneira temporizada de parede para lavatório Assi (cromado) | Timer tap washbasin Assi | Robinet poussoir pour lavabo Assi
- 50667030 | 04. Torneira temporizada para lavatório | Timer mixer basin Assi | Timer robinet lavabo Assi

- 50667092 | 05. Misturadora de chuveiro temporizada Assi **N**
- 50649122 | 06. Torneira temporizada de chuveiro encastrada Assi | Timer mixer urinal Assi | Timer robinet urinoir Assi
- 50649112 | 07. Torneira temporizada de urinol Assi | Timer mixer urinal Assi | Timer robinet urinoir Assi

- 50683082 | Chuveiro Temporizado exterior **Spacio** **N**
Outdoor shower timer **Spacio** | Douche extérieur poussoir **Spacio** *

* **Chuveiro anti-vandalismo**
Anti vandal shower
Anti vandal douche

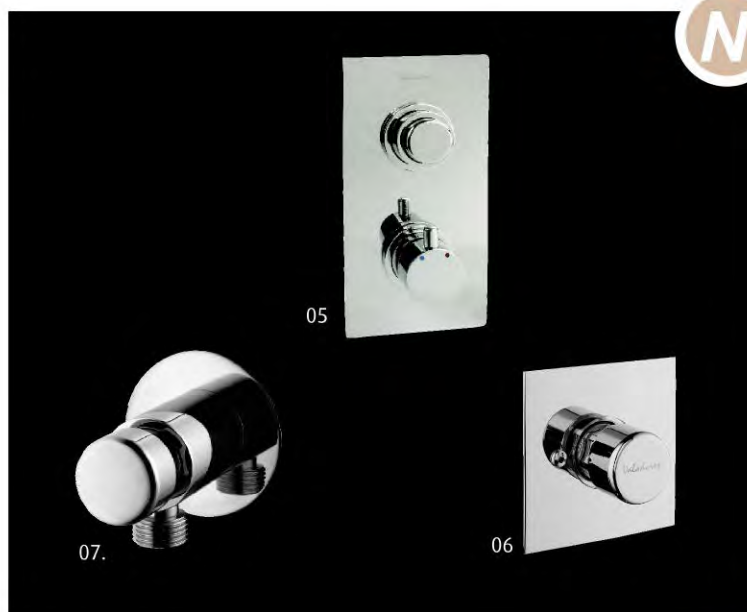

N

N

FLUXO



TORNEIRAS

FAUCETS | ROBINETTERIE DE SALLE DE BAIN

50667052 | Torneira temporizada de lavatório FLUXO
 Timer tap for washbasin "Fluxo"
 Timer robinet "Fluxo" pour lavabo



50603032 | 01. Fluxómetro exterior para sanita c/ regulação de caudal FLUXO (cromado)
 Outside flowmeter for wc with flow adjustment | Fluxomètre pour wc avec
 ajustement de flux

50603022 | 02. Fluxómetro de embutir para sanita FLUXO (cromado) | Inlay flowmeter for wc |
 Fluxomètre embed pour wc



55166020 | 01. Fluxómetro exterior para urinol c/ regulação de caudal FLUXO (cromado)
 Outside flowmeter for urinal with flow adjustment | Fluxomètre extérieur pour
 urinoir avec ajustement de flux

55166030 | 02. Fluxómetro de embutir para urinol FLUXO (cromado) | Inlay flowmeter for urinal
 | Fluxomètre embed pour urinoir

COLONNES/PANNEAU DOUCHE | COLUMNS/SHOWER SCREENS | COLUNAS/RESGUARDOS





CARACTERÍSTICAS:

- Corpo principal em GRESANIT;
- Componentes metálicos integralmente produzidos em latão, com cromagem de grande qualidade
- resistência ao nevoeiro salino superior a 500 horas;
- Misturadora termostática e válvula com dispositivo distribuidor de cinco vias;
- Chuveiro manual com suporte de parede;
- 6 injectores com regulação de orientação, dispostas em grupos de duas unidades;
- Grande facilidade de instalação;
- Garantia geral de 5 anos.

FEATURES:

- Main body in GRESANIT;
- Metal components made entirely of brass with chrome plating of high quality - resistance to salt spray than 500 hours;
- Thermostatic mixing valve and device distributor with five tracks;
- Hand shower with wall bracket;
- 6 injectors with regulatory guidance, arranged in three groups of two units;
- Easy to install;
- Guarantee of 5 years general.

CARACTERISTIQUES:

- Corps principal GRESANIT;
- Les composants métalliques entièrement en laiton avec chromage de haute qualité - résistance au brouillard salin de 500 heures;
- Mitigeur thermostatique et distributeur dispositif avec cinq titres;
- Douchette avec support mural;
- 6 Injecteurs avec les orientations réglementaires, répartis en trois groupes de deux unités;
- Facile à installer;
- Garantie de 5 ans en générale.

COLUNAS

COLUMNS | COLONNES



43051006 Coluna cerâmica de hidromassagem com misturadora termostática **TISSUS**
Wall mounted thermostatic whirlpool column in ceramic "**TISSUS**"
Colonne ceramique hydromassage thermostatique "**TISSUS**"



- 50683072 Chuveiro **Dib** | Shower **Dib** | Douche **Dib**
50601022 Misturadora chuveiro/banheira de encastrar **Dib** | Mixer shower/bathtub recessed **Dib** |
Mélangeur douche/baignoire encastrée **Dib**
50601032 Misturadora de base de chuveiro de encastrar **Dib** | Mixer shower base recessed **Dib** | Bac
douche encastrée mélangeur **Dib**
55173010 Tomada de água com suporte de chuveiro | Socket water with shower arm | Prise l'eau avec
douche
50697052 Chuveiro manual | Hand shower | Douchette à main
50617022 Bicha chuveiro | shower spout | Bec de douche



43021006 Coluna de hidromassagem Termostática de parede **Michigan**
 Wall mounted thermostatic whirlpool column **Michigan**
 Colonne hidromassage thermostatique **Michigan**



COLUMNAS

COLUMNS | COLONNES



43020006 Coluna de hidromassagem Monocomando de parede **Michigan**
 Wall mounted monobloc whirlpool column **Michigan**
 Colonne hidromassage avec mélangeur **Michigan**

Garantia: A coluna de hidromassagem Michigan tem 5 anos para todos os componentes e 3 anos para o sistema
 Garantie: 5 years for components and 3 years for system
 Garantie: Colonne Hidromassage Michigan avec 5 ans garantie pour toute complements e 3 ans pour le système



43011006 | Coluna de hidromassagem Termostática de parede **Sri Lanka**
Wall mounted thermostatic whirlpool column **Sri Lanka**
Colonne thermostatique **Sri Lanka**

COLUNAS

COLUMNS | COLONNES

43010006 | Coluna de hidromassagem Monocomando de parede **Sri Lanka**
Wall mounted monobloc whirlpool column **Sri Lanka**
Colonne hidromassage **Sri Lanka**



Garantia: A coluna de hidromassagem Sri Lanka tem 5 anos para todos os componentes e 3 anos para o sistema
Guarantee: 5 years for components and 3 years for system
Garantie: Colonne Hidromassage Sri Lanka avec 5 ans garantie pout toute complements e 3 ans pour le sistème



43060006 Coluna **Comoros** termostática p/ base de chuveiro
 Wall mounted thermostatic whirlpool column **Comoros**
 Colonne pour bac a douche **Comoros**



43061006 Coluna **Comoros** termoestática para banheira
 Wall mounted thermostatic whirlpool column **Comoros**
 Colonne hidromassage pour baignoire **Comoros**

Garantia: A coluna de hidromassagem Comoros tem 5 anos para componentes e 3 anos para o sistema
 Guarantee: 5 years for components and 3 years for system
 Garantie: Colonne Hidromassage Comoros avec 5 ans garantie pout toute complements e 3 ans pour le sistéme

50680112 **01** Misturadora de chuveiro c/ coluna de chuveiro **Cairo**
 Column shower mixer with arm and rose **Cairo**
 Mitigeur de douche colonne avec douche **Cairo**

50680122 **02** Misturadora de banheira c/ coluna de chuveiro **Cairo**
 Column shower mixer with arm and rose **Cairo**
 Mitigeur de douche colonne avec douche **Cairo**

COLUNAS

COLUMNS | COLONNES



50680132 **01** Misturadora de chuveiro c/ coluna de chuveiro **Calcutá**
 Column shower mixer with arm and rose **Calcutá**
 Mitigeur de douche colonne avec douche **Calcutá**

50680132 **02** Misturadora de banheira c/ coluna de chuveiro **Calcutá**
 Column shower mixer with arm and rose **Calcutá**
 Mitigeur de douche colonne avec douche **Calcutá**



50683042 Chuveiro redondo **Cairo** (Ø 20 cm)
Arm and rose **Cairo** (Ø 20 cm)
Douche rond **Cairo** (Ø 20 cm)



50697232 Haste de Parede | Stem wall | Mur souches (1)
50697242 Haste de tecto **Cairo** (Ø 10 cm) | Rod roof | Toit souches (2)
50697252 Haste de tecto **Cairo** (Ø 20 cm) | Rod roof | Toit souches (3)
50697262 Haste de tecto **Cairo** (Ø 30 cm) | Rod roof | Toit souches (4)

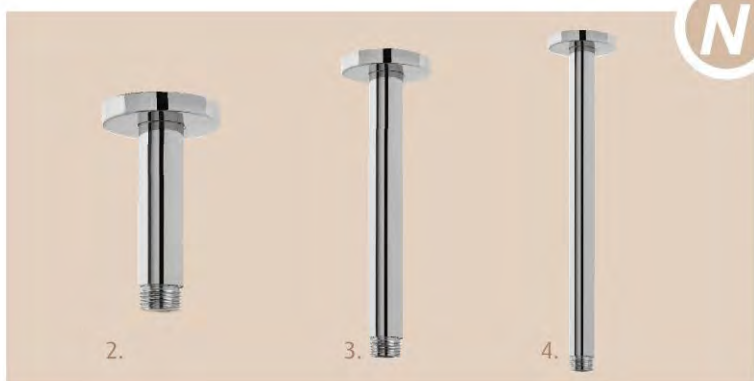

COLUNAS

COLUMINS | COLONNES



50683062 Chuveiro quadrado **Calcutá** (20 x 20cm)
Arm and rose **Calcutá** (20 x 20cm)
Douche Carré **Calcutá** (20 x 20cm)



50697232 Haste de Parede | Stem wall | Mur souches (1)
50697242 Haste de tecto **Calcutá** (Ø 10 cm) | Rod roof | Toit souches (2)
50697252 Haste de tecto **Calcutá** (Ø 20 cm) | Rod roof | Toit souches (3)
50697262 Haste de tecto **Calcutá** (Ø 30 cm) | Rod roof | Toit souches (4)

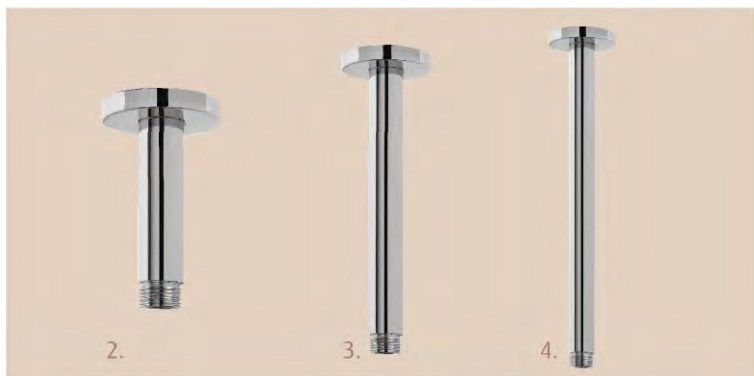



Valadares

52714001	Cabine chuveiro anodizado Shower Screen anodized	Cabinet de douche anodisé Splash 70x70 cm
52714011	Cabine chuveiro anodizado Shower Screen anodized	Cabinet de douche anodisé Splash 75x75 cm
52714021	Cabine chuveiro anodizado Shower Screen anodized	Cabinet de douche anodisé Splash 80x80 cm
52714031	Cabine chuveiro anodizado Shower Screen anodized	Cabinet de douche anodisé Splash 90x90 cm
52714041	Cabine chuveiro anodizado Shower Screen anodized	Cabinet de douche anodisé Splash 90x70 cm
52714051	Cabine chuveiro anodizado Shower Screen anodized	Cabinet de douche anodisé Splash 100x70 cm
51714061	Cabine chuveiro anodizado Shower Screen anodized	Cabinet de douche anodisé Splash 120x70 cm
52714171	Cabine chuveiro anodizado Shower Screen anodized	Cabinet de douche anodisé Splash 140x70 cm(1)
52714071	Cabine chuveiro anodizado Shower Screen anodized	Cabinet de douche anodisé Splash 90x75 cm
52714081	Cabine chuveiro anodizado Shower Screen anodized	Cabinet de douche anodisé Splash 100x75 cm
52714091	Cabine chuveiro anodizado Shower Screen anodized	Cabinet de douche anodisé Splash 120x75 cm
52714101	Cabine chuveiro anodizado Shower Screen anodized	Cabinet de douche anodisé Splash 140x75 cm(1)
52714111	Cabine chuveiro anodizado Shower Screen anodized	Cabinet de douche anodisé Splash 100x80 cm
52714121	Cabine chuveiro anodizado Shower Screen anodized	Cabinet de douche anodisé Splash 120x80 cm
52714131	Cabine chuveiro anodizado Shower Screen anodized	Cabinet de douche anodisé Splash 140x80 cm(1)
52714141	Cabine chuveiro anodizado Shower Screen anodized	Cabinet de douche anodisé Splash 160x80 cm(1)



SÉRIE SPLASH | SPLASH SET | ASSAMBLE SPLASH
 Construída com perfis em alumínio e vidro temperado de 6mm.
 (1) - vidro de 8 mm. | A altura é de 185cm. Fecho magnético.
 Frame in aluminum and 6 mm glass.
 (1) - 8 mm glass. | 1850 mm high - magnetic lock.
 Fabrication avec aluminium profilé et verre 6mm.
 (1) - verre 8 mm. | Hauteur 1865 cm. Fermeture magnétique

RESGUARDOS

SHOWER SCREENS | PANNEAU DOUCHE

52716001	Cabine chuveiro de canto anodizado Egg 90x90 cm N Shower Screen anodized Egg	Cabinet de douche anodisé Egg 90x90 cm
52714151	Cabine chuveiro canto anodizado Shower Screen anodized	Cabinet de douche anodisé Splash 80x80 cm
52714161	Cabine chuveiro canto anodizado Shower Screen anodized	Cabinet de douche anodisé Splash 90x90 cm

SÉRIE SPLASH | SPLASH SET | ASSAMBLE SPLASH

Construída com perfis em alumínio e vidro temperado de 6mm. Disponível nas opções:
 A altura é de 185cm. Fecho magnético.
 Frame in aluminum and 6 mm glass.
 1850 mm high - magnetic lock.
 Fabrication avec aluminium profilé et verre 6mm.
 Hauteur 1865 cm. Fermeture magnétique



N



52715001 | Painel para banheira anodizado | Panel for bathtub anodized
Panneau pour baignoire anodisé Splash

SÉRIE SPLASH | SPLASH SET | ASSAMBLE SPLASH

Painel de banheira com abertura para dentro e para fora, 80cm de comprimento e 140 de altura. Perfis verticais em alumínio. Vidro temperado 6mm.

Bathtub screen with opening to exterior, 80 cm width by 140 cm high. Glass 6 mm.

Panneau pour baignoire avec ouverture pour dedans et pour hors, 80 cm de longueur et 140 hauteur. Aluminium profilé vertical. Verre 6mm.

RESGUARDOS
SHOWER SCREENS | PANNEAU DOUCHE



ACCESSOIRES | ACCESSORIES | **ACESSÓRIOS**





ACESSÓRIOS CERÂMICOS / CERAMIC ACCESSORIES / ACCESSOIRES PORCELAINE SANITAIRE

Anti-fungos / Anti-funguses / Anti-fongus

Fácil limpeza / Easy clening / Ménage Facile

Cor inalterável / Unalterable colour / Couleur inaltérable

Fácil aplicação / Easy instalation / Application facile

Resistentes ás manchas / Stain proof / Résistant taches

Grande resistência mecânica / High mechanical resistance / Gross resistance mécanique

Resistente aos choques térmicos / Resistance to thermic shock / Resistance choc thermique

Resistente aos produtos abrasivos / Abrasive agents-proof / Resistance produit abrasif

Enquadramento com os revestimentos / Fitting the covers and wares / Encadrement avec les carreau

Resistência aos agentes químicos / Resistance to chiminal agents / Resistance Agentes chimiques

Resistência aos ácidos / Acid-proof / Resistance acides

ACESSÓRIOS
ACCESSORIES | ACCESSOIRES

DUETTO

N

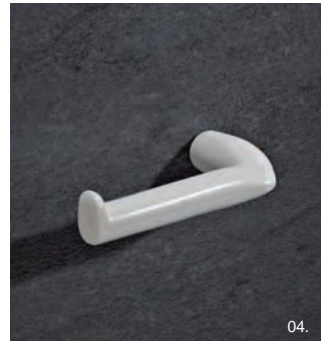

- 23001XX2 01. Cabide | Robe hook | Hanter (80 x 70 x 30 mm)
- 23100XX2 02. Porta-piçaba | Toilet brush holder | Balayette (220 x 140 x 100 cm)
- 23924XX2Y 03. Vassoura | Brush | Balai (70 x 250 cm)
- 23200XX2 04. Porta-rolô | Toilet paper holder | Porte papier (150 x 75 x 30 cm)
- 23360XX2 05. Prateleira | Large shelf | Tablete (490 x 95 x 30 cm)
- 23400XX2 06. Saboneteira pequena | Soap tray | Porte savon (145 x 90 x 30 cm)
- 23401XX2 07. Saboneteira grande | Soap tray | Porte savon (295 x 90 x 30 cm)
- 22630XX2Y 08. Varão | Porcelain rail | Barre 30 cm (310 x 80 x 30)
- 22650XX2Y 09. Varão | Porcelain rail | Barre 50 cm (510 x 80 x 30)
- 22660XX2Y 10. Varão | Porcelain rail | Barre 60 cm (610 x 80 x 30)

XX - CORES DISPONÍVEIS | AVAILABLE COLOURS | COULEURS DISPONIBLES
 Branco 45 | Preto 48 (VER PÁG. 8 | SEE PAGE 8 | REGARDER PAGE.8)
 Acabamento (Y): Faia (F) | Mogno (M) | Wenguê (W)

ACESSÓRIOS

ACCESSORIES | ACCESSOIRES

DESIGN: RUTE ROSA, designer

- | | |
|----------|---|
| 24001XX2 | 01. Cabide Robe hook Hanter (13 x 7 cm) |
| 24100XX2 | 02. Porta-piaçaba Toilet brush holder
Balayette (20,5 x 11,5 cm) |
| 24924XX2 | 03. Vassoura Brush Balai |
| 24200XX2 | 04. Porta-rolô Toilet paper holder
Porte papier (18,5 x 7 cm) |
| 24350XX2 | 05. Prateleira Large shelf Tablete (50 x 11 cm) |
| 24400XX2 | 06. Saboneteira pequena Soap tray
Porte savon (16,7 x 8 cm) |
| 24401XX2 | 07. Saboneteira grande Soap tray
Porte savon (30,5 x 9 cm) |
| 24530XX2 | 08. Toalheiro Towel rail Serviette (30 cm) |
| 24540XX2 | 09. Toalheiro Towel rail Serviette (40 cm) |

CORES DISPONÍVEIS | AVAILABLE COLOURS | COULEURS DISPONIBLES
a) 00 b) 48 (VER PÁG. 8 | SEE PAGE 8 | REGARDER PAGE 8)

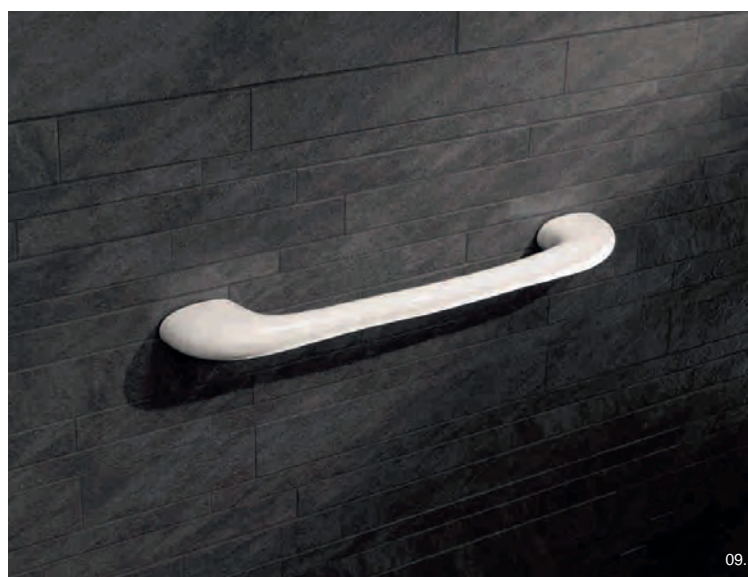
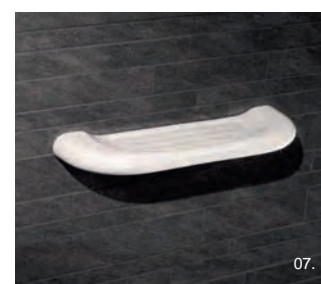
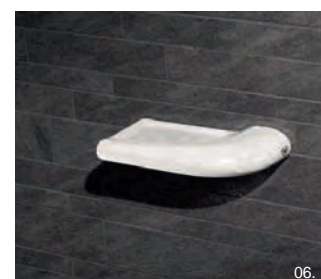
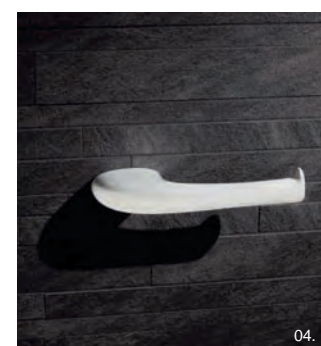

DESIGN: RUTE ROSA, designer

ALFA



01.



02+12.



03.



04.



05.



06.



07.



08.



09.

- | | |
|----------|--|
| 22001XX2 | 01. Cabide Robe hook Hanter 8 x 6cm |
| 22100XX2 | 02. Porta-piaçaba Toilet brush holder Balayette 16 x 11cm
(não inclui vassoura/ brush not included/ Sans balai) |
| 22200XX2 | 03. Porta-rolô Toilet paper holder Porte papier 18 x 10cm |
| 22360XX2 | 04. Prateleira Large shelf Tablete 60 x 13cm |
| 22400XX2 | 05. Saboneteira Soap tray Porte savon 15 x 10cm |
| 22401XX2 | 06. Saboneteira / esponjeira de embutir Soap and
sponge tray Porte savon double encastrer 30 x 13cm |
| 22500XX2 | 07. Suporte para toalheiro Brackets for
towel rail Porte serviette 4 x 10 cm |
| 22630XX2 | 08. Varão Porcelain rail Barre 30 cm |
| 22640XX2 | 09. Varão Porcelain rail Barre 40 cm |
| 22650XX2 | 10. Varão Porcelain rail Barre 50 cm |
| 22660XX2 | 11. Varão Porcelain rail Barre 60 cm |
| 55020001 | 12. Vassoura Brush Balai |

CORES DISPONÍVEIS | AVAILABLE COLOURS | COULEURES DISPONIBLES
a) 00 | 16 | 20 b) 01 (VER PÁG. 8 | SEE PAGE 8 | REGARDER PAGE 8)

Kitpack Alfa composto por:

1 cabide, 1 porta-piaçaba, 1 vassoura, 1 porta-rolô,
1 saboneteira (15 x 10cm), 6 suportes de toalheiro,
1 varão de 30 cm, 1 varão de 50 cm e 1 varão de 60 cm

Visipack Alfa composed of: 1 hook, 1 toilet brush holder,
1 brush, 1 toilet roll, 1 soap tray (15 x 10cm), 6 brackets,
1 porcelain rail 30 cm, 1 porcelain rail 50 cm and
1 porcelain rail 60 cm

Kitpack Alfa composition: 1 Patère, 1 Balayette, 1 Balai,
1 Porte Papier, 1 Porte Savon (15 x 10cm),
6 Porte Serviette, 1 Barre de 30 cm, 1 Barre de 50 cm
et 1 Barre de 60 cm

ACESSÓRIOS

ACCESSORIES | ACCESSOIRES

- 26001XX2 01. Cabide | Robe hook | Hanter 9 x 7 cm
- 26100XX2 02. Porta-piçaba | Toilet brush | Balayete 18 x 12 cm (não inclui vassoura/
brush not included/ sans balai)
- 26200XX2 03. Porta-rolô | Toilet paper holder | Porte Papier 22 x 10 cm
- 26400XX2 04. Saboneteira N1 | Soap tray N1 | Porte Savon N1 16 x 11 cm
- 26404XX2 05. Saboneteira N2 | Soap tray N2 | Porte Savon N2 24 x 12 cm
- 26500XX2 06. Suporte para toalheiro | Brackets for towel rail | Porte Serviette 11 x 9 cm
- 22630XX2 07. Varão | Porcelain rail | Barre 30 cm
- 22640XX2 08. Varão | Porcelain rail | Barre 40 cm
- 22650XX2 09. Varão | Porcelain rail | Barre 50 cm
- 22660XX2 10. Varão | Porcelain rail | Barre 60 cm
- 55020001 11. Vassoura | Brush | Balai

CORES DISPONÍVEIS | AVAILABLE COLOURS | COULEURS DISPONIBLES
a) 00 | 16 (VER PÁG. 8 | SEE PAGE 8 | REGARDER PAGE 8)



ACESSÓRIOS

ACCESSORIES | ACCESSOIRES

ORION

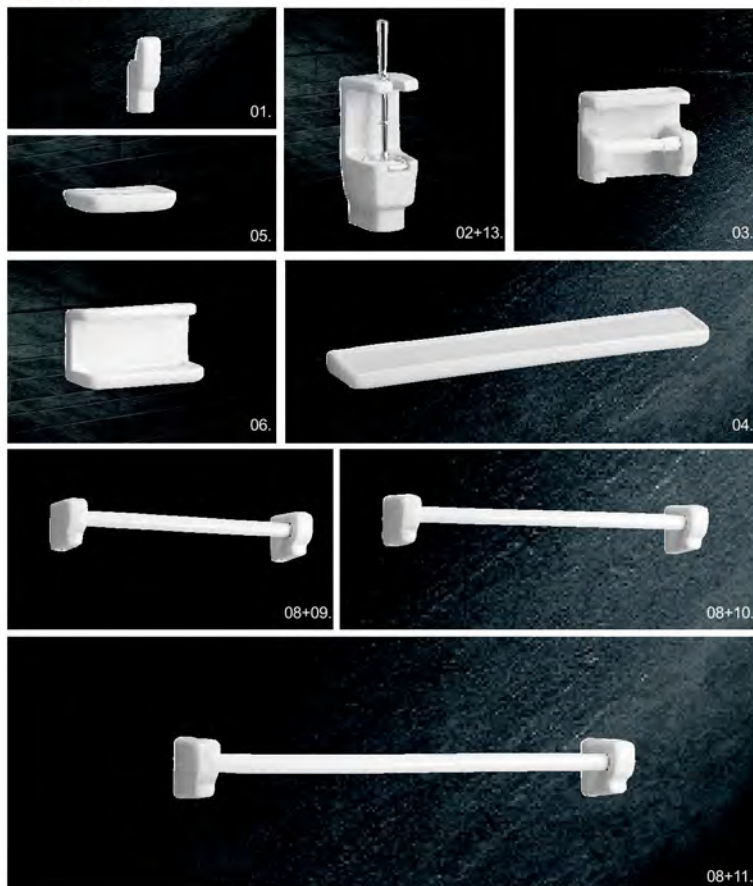

- 25001XX2 01. Cabide simples | Robe hook | Patère 4 x 13 cm
- 25100XX2 02. Porta-piaçaba c/ copo | Toilet brush holder | Porte balayete (não inclui vassoura/ brush not included/ sans balai)
- 25200XX2 03. Porta-rolô | Toilet paper holder | Porte papier 18 x 15 cm
- 25360XX2 04. Prateleira | Shelf | Tablete 60 x 12 cm
- 25401XX2 05. Saboneteira esponjeira | Port savon double 25 x 14 cm
- 25400XX2 06. Saboneteira | Soap tray | Porte savon 16 x 11 cm
- 25501XX2 07. Suporte toalheiro direito | Brackets for towel rail right | Porte serviette droite 3,5 x 8 cm
- 25502XX2 08. Suporte toalheiro esquerdo | Brackets for towel rail left | Porte serviette gauche 3,5 x 8 cm
- 22630XX2 09. Varão | Porcelain rail | Barre 30 cm
- 22640XX2 10. Varão | Porcelain rail | Barre 40 cm
- 22650XX2 11. Varão | Porcelain rail | Barre 50 cm
- 22660XX2 12. Varão | Porcelain rail | Barre 60 cm
- 55020001 13. Vassoura | Brush | Balai

CORES DISPONÍVEIS | AVAILABLE COLOURS | COULEURS DISPONIBLES
a) 00 | 16 | 20 (VER PÁG. 8 | SEE PAGE 8 | REGARDER PAGE 8)

Kitpack Orion composto por: 1 cabide, 1 porta-piaçaba c/ copo, 1 vassoura, 1 porta-rolô, 1 saboneteira 16 x 11 cm, 6 suportes de toalheiro, 1 varão 30 cm, 1 varão 50 cm, 1 varão 60 cm

Visipack Orion composed of: 1 robe hook, 1 toilet brush holder, 1 brush, 1 toilet paper holder, 1 soap tray 16 x 11 cm, 1 porcelain rail 30 cm, 1 porcelain rail 50 cm, 1 porcelain rail 60 cm.

Kitpack Orion avec composition: 1 Patère, 1 Porte Balayete, 1 Balai, 1 Porte Papier, 1 Porte Savon 16x11 cm, 1 Porte Serviette 30 cm, 1 Porte Serviette de 50 cm, 1 Porte Serviette de 60 cm.

LÍDER

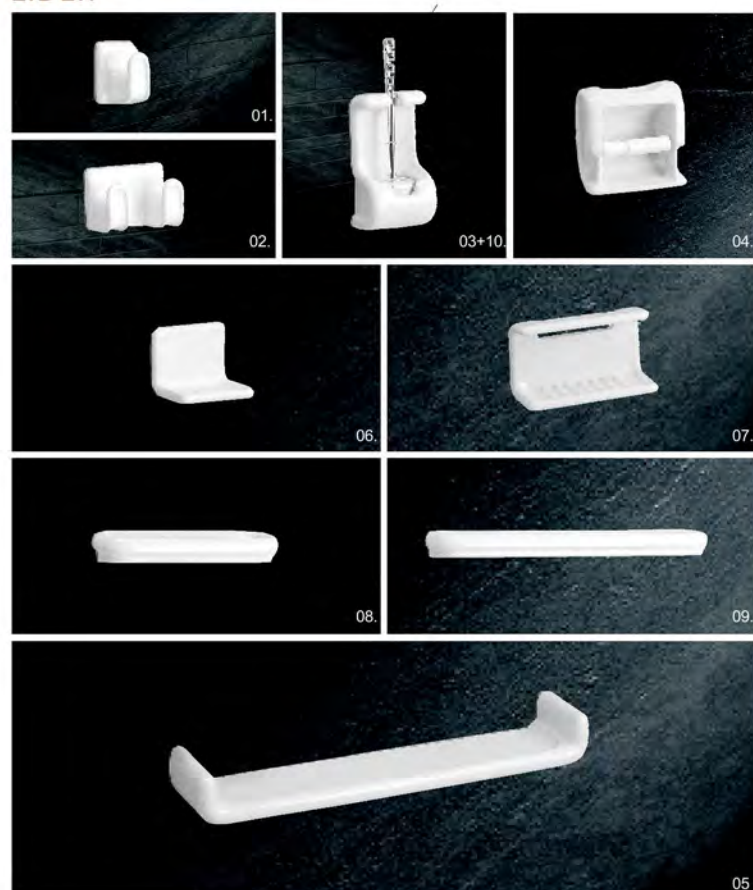

- 20001XX2 01. Cabide simples | Single robe hook | Patère 15 x 9 cm
- 20000XX2 02. Cabide duplo | Double robe hook | Patère double 18 x 18 cm
- 20100XX2 03. Porta-piaçaba c/ copo | Toilet brush holder | Porte Balayete 24 x 16 cm (não inclui vassoura/ brush not included/ sans balai)
- 20200XX2 04. Porta-rolô | Toilet paper holder | Porte papier 8 x 7,5 cm
- 20360XX2 05. Prateleira | Shelf | Tablete 62 x 12 cm
- 20400XX2 06. Saboneteira | Soap tray | Porte savon 13 x 10 cm
- 20401XX2 07. Saboneteira com pega | Soap tray with grips | Porte savon avec poigne 22 x 10 cm
- 20530XX2 08. Toalheiro | Porcelain rail | Porte serviette 30 x 9 cm
- 20550XX2 09. Toalheiro | Porcelain rail | Porte serviette 50 x 9 cm
- 55020001 10. Vassoura | Brush | Balai

CORES DISPONÍVEIS | AVAILABLE COLOURS | COULEURS DISPONIBLES
a) 00 | 16 | 20 b) 01 (VER PÁG. 8 | SEE PAGE 8 | REGARDER PAGE 8)

ACESSÓRIOS
ACCESSORIES | ACCESSOIRES



COMPLÉMENTS | COMPLEMENTS | **COMPLEMENTOS**





EGG

COMPACTO

- 55185000 Sistema de fixação lateral (bacia, bidé e lavatório de coluna)
- 55114010 Curva de descarga
- 55150180 Kit de fixação posterior p/ bacia compacta
- 55041082 Kit de instalação p/ bacia comp. back to wall

BTW

- 55185000 Sistema de fixação lateral (bacia, bidé e lavatório de coluna)
- 55040010 Tubo de descarga horizontal 250 mm
- 55150190 Kit de fixação posterior p/ bacia back to wall

SUSPENSO

- 55150200 Kit de fixação à parede (bacia, bidé)
- 55150210 Kit de fixação à parede (lavatório suspenso)

COMPACTO

- 55185000 Lateral fixation system (wc, bidet and washbasin)
- 55114010 Discharge curve
- 55150180 Fixation kit for wc monoblock
- 55041082 Fixation kit for wc btw

BTW

- 55185000 Fixation system (side) wc, bidet and washbasin
- 55040010 Horizontal outlet pipe
- 55150190 Fixation kit for btw

WALL HUNG

- 55150200 Fixation kit (wc, bidet)
- 55150210 Fixation kit (washbasin)

COMPACTO

- 55185000 Système de fixation lateral (wc, bidet, lavabo)
- 55114010 Courbe de décharge
- 55150180 Kit fixation wc compact
- 55041082 kit fixation wc btw

BTW

- 55185000 Système de fixation lateral (wc, bidet et lavabo)
- 55040010 Tube d'évacuation horizontale
- 55150190 kit fixation pour btw

SUSPENDU

- 55150200 Kit fixation (wc, bidet)
- 55150210 Kit fixation (lavabo)

ASSIMÉTRICA

- 55023030 Tubo em pvc c/ 400mm para descarga à parede
- 55114020 Curva em abs para descarga ao chão (distância à parede 210 +/- 20mm)
- 55040000 Curva em pvc para descarga ao chão (distância à parede 165 +/- 5mm)
- 55007001 Kit fixação nº 1 (para lavatório normal)
- 55185000 Sistema de fixação lateral
- 55126010 Kit fixação coluna suspensa
- 55108081 Pulsador p/ mecanismo dd cromado
- 55167000 Cabo p/ mecanismo
- 55078041 Dobradiça aço inox tampo termodur bacia (par)
- 55073011 Dobradiça soft-close p/ tampo termodur bacia (par)

- 55023030 PVC pipe with 400 mm for "p" trap
- 55114020 Curve outlet pipe in ABS for "s" trap (distance to wall 210 +/- 20mm)
- 55040000 Curve outlet pipe in ABS for "s" trap (distance to wall 165 +/- 5mm)
- 55007001 Screw kit N1 for washbasin
- 55185000 Kit Fixation N5 (wc + bidet)
- 55126010 Kit Fixation for 1/2 Pedestal
- 55108081 Chromed plated push down button
- 55167000 Cable for mechanism
- 55078041 Hinges for seat & cover termodur (set)
- 55073011 Hinges for Soft-Close Seat termodur (set)

COMPLEMENTOS

COMPLEMENTS | COMPLÉMENTS

- 55023030 Tube PVC de vidage 400 mm au mur
- 55114020 Courbe de vidage ABS (distance mur 210 +/- 20mm)
- 55040000 Courbe de vidage ABS (Distance mur 165 +/- 5mm)
- 55007001 Kit fixation N1 (p/lavabo normale)
- 55185000 Kit fixation N5 (wc + bidet)
- 55126010 Kit fixation (p/demi-colonne suspendu)
- 55108081 Pulsateur chromé p/reservoir
- 55167000 Cable pour mécanism
- 55078041 Charnière p/abattant Termodur
- 55073011 Charnière p/abattant "Soft Close"Termodur

LIGHT

- 55007001 Kit fixação nº 1 (para lavatório)
- 55033000 Kit fixação nº 6 (para bacia e bidé)
- 55109151 Sifão reduzido em latão cromado (para bidé e bidé suspenso)
- 55161051 Dobradiça tampo cm (par)
- 55109151 Sifão reduzido para bidé suspenso

- 55007001 Screw Kit N 1 for washbasin
- 55033000 Screw Kit N 6 for Wc + Bidet
- 55109151 Chromed plated siphon for bidet
- 55161051 Hinged for seat and cover
- 55109151 Reduce siphon for bidet wall hung

- 55007001 Kit fixation N1 p/lavabo
- 55033000 Kit fixation N6 p/WC et Bidet
- 55109151 Siphon réduit en laiton chromé (bidet)
- 55161051 Charnière p/ abattant bois maritime
- 55109151 Réduit siphon pour bidet suspendu

NAUTILUS

- 55023030 Tubo em pvc c/400mm para descarga à parede
- 55114010 Curva em abs para descarga ao chão (distância à parede 210 +/- 20mm)
- 55007001 Kit fixação nº 1 (para lavatório)
- 55185010 Sistema de fixação lateral bacia/bidé
- 55126010 Kit fixação coluna suspensa
- 55108091 Pulsador p/mecanismo dd cromado
- 55073021 Dobradiça soft-close p/tampo termodur bacia (par)
- 55078051 Dobradiça aço inox p/tampo termodur bacia (par)
- 55077101 Dobradiça aço inox p/tampo termodur bidé (par)
- 55041082 Kit de instalação p/ bacia comp. back to wall (válvula de passagem c/ filtro e flexível p/ alimentação mecanismo)

- 55023030 PVC pipe with 400 mm for "p" trap
- 55114010 Curve outlet pipe in ABS for "s" trap (distance to wall 210 +/- 20mm)
- 55007001 Screw kit N1 for washbasin
- 55185010 Side fixation system for wc / bidet
- 55126010 Fixing kit for wall hung pedestal
- 55108091 Chromed plated push down button
- 55073021 Hinges for Soft-Close Seat termodur (set)
- 55078051 Hinges for seat & cover termodur (set)
- 55077101 Hinges for Bidet seat termodur (set)
- 55041082 Installation kit for btw (pass filter with valvet)

55023030	Tube PVC de vidage 400 mm au mur
55114010	Courbe de vidage au sol ABS (distance mur 210 +/- 20mm)
55007001	Kit fixation N1 (p/lavabo)
55185010	Système de fixation lateral p/ wc/bidet
55126010	Kit fixation colonne suspendu
55108091	Pulsateur chromé p/reservoir
55073021	Charnière p/abattant "Soft Close"Termodur
55078051	Charnière p/abattant cuvette
55077101	Charnière p/abattant de bidet Termodur
55041082	Kit fixation pour btw (filtre passe avec vidage)

NAUTILUS SUSPENSO

55033000	Kit fixação n° 6 (para bacia e bidé)
55126010	Kit fixação coluna suspensa
55073021	Dobradiça soft-close p/tampo termodur bacia (par)
55078051	Dobradiça aço inox p/tampo termodur bacia (par)
55077101	Dobradiça aço inox p/tampo termodur bidé (par)

55033000	Screw kit N6 WC or bidet
55126010	Fixing kit for wall hung pedestal
55073021	Hinges for seat & cover Soft Close termodur (set)
55078051	Hinges for seat & cover termodur (set)
55077101	Hinges for Bidet seat termodur (set)

55033000	Kit fixation N6 (p/Cuvette et Bidet)
55126010	Kit Fixation p/demi-colonne suspendu
55073021	Charnière p/abattant "Soft Close"Termodur
55078051	Charnière p/abattant Termodur
55077101	Charnière p/abattant de bidet Termodur

OPORTO

30912XX2	Tampa p/tanque FT45 (sujeita a prazo de entrega)
55023030	Tubo em pvc c/400mm para descarga à parede
55023020	Curva em pvc wirquin para descarga ao chão (distância à parede 225mm)
55040000	Curva em pvc para descarga ao chão (distância à parede 175 +/- 5mm)
55007001	Kit fixação n° 1 (para lavatório normal)
55185000	Sistema de fixação lateral bacia/bidé
55126010	Kit fixação coluna suspensa
55078011	Dobradiça aço inox p/tampo termodur bacia (par)
55108121	Pulsador cromado dd Geberit duo ii

30912XX2	Lid for cistern (subject to delivery time)
55023030	Flexible curve outlet pipe (p trap)
55023020	Curve outlet pipe in PVC for "S" trap 225 mm
55040000	Curve outlet pipe in PVC for "S" trap 175 mm
55007001	Screw kit N1 for washbasin
55185000	Side fixation system for wc / bidet
55126010	Fixing kit for wall hung pedestal
55078011	Hinges for seat & cover Termodur
55108121	Chromed plated 3/6 It push down button Geberit

30912XX2	Couvercle p/reservoir (sujet delai livraison)
55023030	Tube de vidage au mur
55023020	Courbe vidage PVC (écoulement au sol 225mm)
55040000	Courbe vidage PVC (écoulement au sol 175 mm)
55007001	Kit Fixation N1 (p/Lavabo normale)
55185000	Système de fixation lateral p/ wc/bidet
55126010	Kit Fixation p/Cuvette Suspendu
55078011	Charnière p/abattant Termodur
55108121	Pulsateur chromé 3/6 It Geberit

COMPLEMENTOS

neoclássica

16912XX2	Tampa p/tanque FT45 (sujeita a prazo de entrega)
16914XX2	Tampa p/tanque s/furo (sujeita a prazo de entrega)
55030001	Pulsador p/mecanismo tipo 1 cromado
55009001	Manípulo frontal p/mecanismo cromado
55007001	Kit fixação n° 1 (para lavatório normal)
55007002	Kit fixação n° 2 (para lavatório médio e júnior)
55007003	Kit fixação n° 3 (para bacia e bidé)
55161001	Dobradiça aço inox p/tampo bacia sífónica (par)
55161011	Dobradiça aço inox p/tampo cm bacia (par)
55113014	Kit batentes p/tampo

16912XX2	Lid for cistern FT45 (subject to delivery time)
16914XX2	Lid for cistern with no hole (subject to delivery time)
55030001	Chromed plated push down button
55009001	Chromed plated frontal lever
55007001	Screw kit N1 for washbasin
55007002	Screw kit N2 for washbasin medium and junior
55007003	Screw kit N3 for hand washbasin
55161001	Hinges for seat & cover normal (set)
55161011	Hinges for seat & cover C/C (set)
55113014	Rubber kit for seat

16912XX2	Couvercle p/reservoir FT45 (sujet delai livraison)
16914XX2	Couvercle p/reservoir sans trou (sujet delai livraison)
55030001	Pulsateur chromé p/reservoir
55009001	Poignée frontal chromé
55007001	Kit fixation N1 (p/lavabo normale)
55007002	Kit fixation N2 (p/lavabo moyen et junior)
55007003	Kit fixation N3 (p/cuvette et Bidet)
55161001	Charnière p/abattant cuvette simple
55161011	Charnière p/abattant cuvette
55113014	Kit butées p/abattant CM

TAGUS

55108010	Pulsador p/mecanismo
55094000	Pulsador p/mecanismo dd
55023030	Tubo em pvc c/400mm para descarga à parede
55114020	Curva em abs para descarga ao chão (distância à parede 210 +/- 20mm)
55007002	Kit fixação n° 2 (para lavatório)
55185000	Sistema de fixação lateral bacia/bidé
55078031	Dobradiça aço inox p/tampo termodur bacia (par)
55113002	Kit batentes p/tampo termodur

55108010	Chromed plated push down button
55094000	Chromed plated push down button DF
55023030	Outlet Pipe in PVC with 400 mm "P" Trap
55114020	Curve outlet pipe in PVC for "S" trap (ditance to wall 210 +/- 20mm)
55007002	Screw kit N2 for washbasin medium and junior
55185000	Side fixation system for wc / bidet
55078031	Hinges for seat & cover termodur (set)
55113002	Rubber kit for seat

55108010	Pulsateur chromé p/reservoir
55094000	Pulsateur chromé p/reservoir DP
55023030	Vidage PVC avec 400 mm sortie mur
55114020	Courbe vidage PVC au sol (écoulement au sol 210 +/- 20 mm)
55007002	Kit fixation N2 (p/lavabo moyen et junior)
55185000	Système de fixation lateral p/ wc/bidet
55078031	Charnière p/abattant cuvette
55113002	Kit butées p/abattant CM



COMPLEMENTS | COMPLÉMENTS

DURIUS

55023020	Curva em pvc p/ descarga ao chão
55023030	Tubo em pvc c/ 400mm p/ descarga à parede
55185000	Sistema de fixação lateral p/ bacia, bidé
55007001	Kit fixação nº1 p/ lavatório normal e médio
55007002	Kit fixação nº2 p/ lavatório júnior
55073001	Dobradiça aço inox soft close p/ tampo (par)
55161031	Dobradiça aço inox p/ tampo (par)
BACK TO WALL	
55040010	Conector descarga horizontal 250 mm
55185000	Sistema fixação lateral bacia, bidé, coluna suspensa
55007001	Kit fixação nº1 para lavatório normal/ médio
55007002	Kit fixação nº2 para lavatório júnior
55161071	Dobradiça aço inox p/ tampo (par)
55041082	Kit instalação p/ bacia comp. back to wall

55023020	Outlet pipe "S" trap
55023030	Outlet pipe PVC "P" trap with 400mm
55185000	Fixation system for Wc / bidet / 1/2 pedestal
55007001	Screws Kit nº1 for washbasin normal / medium
55007002	Screws Kit nº2 for washbasin junior
55073001	Hinges for seat and cover soft-close
55161031	Hinges for seat and cover

BACK TO WALL	
55040010	Outlet pipe PVC "P" trap with 250 mm
55185000	Fixation system for Wc / bidet / 1/2 pedestal
55007001	Screws Kit nº1 for washbasin normal / medium
55007002	Screws Kit nº2 for washbasin junior
55161071	Hinges for seat and cover soft-close
55041082	Kit instalation for btw

55023020	Courbe vidage PVC ausol
55023030	Vidage PVC 400mm sortie mur
55185000	Kit fixation pour wc/bidet 1/2 colonne
55007001	Kit fixation pour lavabo normalemoyen
55007002	Kit fixation pour lavabo junior
55073001	Charnière pour abattant soft-close
55161031	Charnière pour abattant

BACK TO WALL	
55040010	Vidage PVC 250mm
55185000	Kit fixation pour wc/bidet 1/2 colonne
55007001	Kit fixation pour lavabo normalemoyen
55007002	Kit fixation pour lavabo junior
55161071	Charnière pour abattant soft-close
55041082	Kit instalation pour btw

DURIUS SUSPENSO

55033000	Kit fixação nº6 p/ bacia e bidé
55185000	Sistema fixação lateral p/ coluna suspensa
55007001	Kit fixação nº1 p/ lavatório normal/ médio
55007002	Kit fixação nº2 p/ lavatório júnior
55073001	Dobradiça aço inox soft-close p/ tampo (par)
55161031	Dobradiça aço inox p/ tampo (par)

55033000	Screw kit N6 WC or bidet
55185000	Fixation system for Wc / bidet / 1/2 pedestal
55007001	Screws Kit nº1 for washbasin normal / medium
55007002	Screws Kit nº2 for washbasin junior
55073001	Hinges for seat and cover soft-close
55161031	Hinges for seat and cover

55033000	Kit fixation N6 (p/Cuvette et Bidet)
55185000	Kit fixation pour wc/bidet 1/2 colonne
55007001	Kit fixation pour lavabo normalemoyen
55007002	Kit fixation pour lavabo junior
55073001	Charnière pour abattant soft-close
55161031	Charnière pour abattant

OPUS

37912002	Tampa para tanque
55023030	Tubo em pvc c/400mm para descarga à parede
55114010	Curva em abs para descarga ao chão (distância à parede 210 +/- 20mm)
55007002	Kit fixação nº 2 (para lavatório)
55185000	Sistema de fixação lateral bacia/bidé
55073031	Dobradiça soft-close p/tampo termodur bacia (par)
55069021	Dobradiça aço inox p/tampo termodur bacia (par)
55161041	Dobradiça aço inox p/tampo contraplacado marítimo bacia (par)
55108121	Pulsador cromado dd Geberit duo ii

37912002	Cistern Lid
55023030	Outlet Pipe in PVC with 400 mm "P" Trap
55114010	Curve outlet pipe in PVC for "S" trap (dittance to wall 210 +/- 20mm)
55007002	Screw kit N2 for washbasin medium and junior
55185000	Side fixation system for wc/bidet
55073031	Soft close hinges for thermoset seat and cover
55069021	Stainless steel hinges for seat and cover thermoset
55161041	Stainless steel hinges for seat and cover maritime wood
55108121	Chromed plated 3/6 lt push down button Geberit

37912002	Covercle pour reservoir
55023030	Vidage PVC avec 400 mm sortie mur
55114010	Courbe vidage PVC au sol (écoulement au sol 210 +/- 20 mm)
55007002	Kit fixation N2 (p/lavabo moyen et junior)
55185000	Kit fixation lateral pour wc/ bidet
55073031	Charnière soft-close pour abattant termodur
55069021	Charnière soft-close pour abattant bois maritime
55161041	Charnière acier inox pour abattant bois maritime
55108121	Pulsateur chromé 3/6 lt Geberit

OPUS SUSPENSO

55033000	Kit fixação nº 6 (para bacia e bidé)
55078081	Dobradiça aço inox p/tampo termodur bacia (par)
55126010	Kit fixação coluna suspensa
55007002	Kit fixação nº2 (lavatório)

55033000	Fixation kit N6 for wc/bidet
55078081	Stainless steel hinges for seat and cover thermoset
55126010	Fixing kit for wall hung pedestal
55007002	Screw kit N2 for washbasin

55033000	Kit fixation N6 pour wc/bidet
55078081	Charnière acier inox abattant termodur
55126010	Kit Fixation p/demi-colonne suspendu
55007002	Kit fixation N2 (p/lavabo)

EUROPA PLUS

33912XX2	Tampa para tanque
55007001	Kit fixação nº 1 (para lavatório normal)
55007002	Kit fixação nº 2 (para lavatório médio e júnior)
55033000	Kit fixação nº 6 (para bacia e bidé)
55007003	Kit fixação nº 3 (para coluna suspensa)
55161011	Dobradiça aço inox p/tampo cm bacia (par)
55070005	Dobradiça plástica p/tampo termodur (par)
55108121	Pulsador cromado dd Geberit duo ii
55113002	Kit batentes p/tampo termodur

33912XX2	Cistern Lid
55007001	Screw kit N1 for washbasin normal
55007002	Screw kit N2 for washbasin medium and junior
55033000	Screw kit N6 for WC or bidet
55007003	Screw kit N3 for 1/2 pedestal
55161011	Hinges for seat & cover termodur (set)
55070005	Hinges for seat & cover maritime wood (set)
55108121	Chromed plated 3/6 It push down button Geberit
55113002	Rubber kit for seat

33912XX2	Covercle pour reservoir
55007001	Kit fixation N1 pour lavabo normal
55007002	Kit fixation N2 pour lavabo moyen et junior
55033000	Kit fixation N6 pour wc et bidet
55007003	Kit fixation N3 pour 1/2 colonne
55161011	Charnière p/abattant Termodur cuvette
55070005	Charnière p/abattant cuvette
55108121	Pulsateur chromé 3/6 It Geberit
55113002	Kit butées p/abattant Termodur

EUROPA SUSPENSO

55007001	Kit fixação nº 1 (para lavatório normal)
55007002	Kit fixação nº 2 (para lavatório médio e júnior)
55033000	Kit fixação nº 6 (para bacia e bidé)
55007003	Kit fixação nº 3 (para coluna suspensa)
55161011	Dobradiça aço inox p/tampo cm bacia (par)
55070005	Dobradiça plástica p/tampo termodur (par)

55007001	Screw kit N1 for washbasin normal
55007002	Screw kit N2 for washbasin medium and junior
55033000	Screw kit N3 for 1/2 pedestal
55007003	Screw kit N6 for WC or bidet
55161011	Hinges for seat & cover termodur (set)
55070005	Hinges for seat & cover maritime wood (set)

55007001	Kit fixation N1 (p/ lavabo normale)
55007002	Kit fixation N2 (p/ lavabo moyen et junior)
55033000	Kit fixation N3 (p/lavabo suspendu)
55007003	Kit fixation N6 (p/ cuvette et bidet)
55161011	Charnière p/abattant Termodur cuvette
55070005	Charnière p/abattant cuvette

COMPLEMENTOS

Complementos Gerais

55118000	Tanque plástico c/mecanismo intermopível
55109031	Sifão tipo garrafa 1 1/4" em latão, c/válvula, cromado
55109041	Sifão tipo garrafa 1 1/4" em latão, p/vda, cromado
55109051	Sifão tipo s 1 1/4" em latão, c/válvula, cromado
55109061	Sifão tipo s 1 1/4" em latão, p/vda, cromado
55081031	Tampo para overflow cromado
55115000	União de descarga excêntrica de 90mm
55125000	Kit fixação p/suporte basculante/regulável lavatório pmr
22700XX2	Botões
55020001	Vassoura plástica cromada p/porta-piaçaba
55004000	Mola plástica p/porta-rolos
55006002	Kit fixação nº4 p/acessórios
55118110	Tanque encastrável dupla descarga
55034161	Placa de comando dd (3/6l) cromada
55034164	Placa de comando dd (3/6l) cromo-mate
55034163	Placa de comando dd (3/6l) branca
55034175	Placa de comando dd (3/6l) metálica cromo-mate
55150220	Conjunto de parafusos de fixação do separador do urinol de cerâmica

General Complementents

55118000	Plastic cistern with mechanism
55109031	Chromed plated siphon 1 1/4 with chromed valve
55109041	Chromed plated siphon 1 1/4 for automatic pop-up
55109051	Chromed plated siphon "S" 1 1/4 chromed valve
55109061	Chromed plated siphon "S" 1 1/4 for automatic pop-up
55081031	Chromed plated cover for overflow
55115000	Eccentric union outlet 90mm
55125000	Fixation kit for adjustable handicap basin
22700XX2	Buttons
55020001	Chromed plated broom for toilet brush holder
55004000	Plastic spring for paper holder
55006002	Fixation kit N4 for accessories
55118110	Wall mounted cistern dual flush
55034161	Chromed plated flush panel 3/6L
55034164	Chromed matt-plated panel 3/6L
55034163	White plated panel 3/6L
55034175	Metal chromed-matt plated flush panel 3/6L
55150220	Fixation kit for urinal divider

Compélements Générales

55118000	Reservoir plastic avec mécanism
55109031	Siphon 1 1/4 metálique avec vidage chromé
55109041	Siphon 1 1/4 metálique avec vidage chromé
55109051	Siphon S1 1/4 metálique avec vidage chromé
55109061	Siphon S1 1/4 metálique avec vidage chromé
55081031	Couvrir metálique pour prélèvement
55115000	Excentrique décharge 90mm
55125000	Kit fixation pour systeme elevation lavabo handicapé
22700XX2	Boutons
55020001	Balai plastique pour balayete
55004000	Printemps plastique pour porte papier
55006002	Kit fixation N4 pour accessoires
55118110	Reservoir encastrer double poussoir
55034161	Plaque chrome 3/6L
55034164	Plaque chrome-matte 3/6L
55034163	Plaque blanc 3/6L
55034175	Plaque metálique chrome-matte 3/6L
55150220	Kit fixation diviseur urinoire



DESENHOS TÉCNICOS | TECHNICAL DRAWING | DESSINS TECHNIQUES

EGG pag.10

Lavatório | washbasin | lavabo

Bacia | WC | WC

Bidé | bidet | bidet

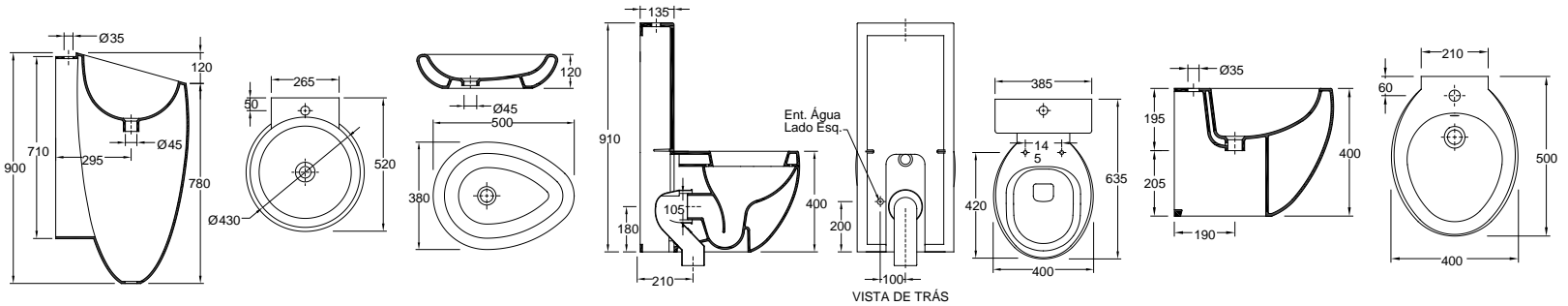

EGG SUSPENSO pag.12

Lavatório | washbasin | lavabo

Bacia | WC | WC

Bidé | bidet | bidet

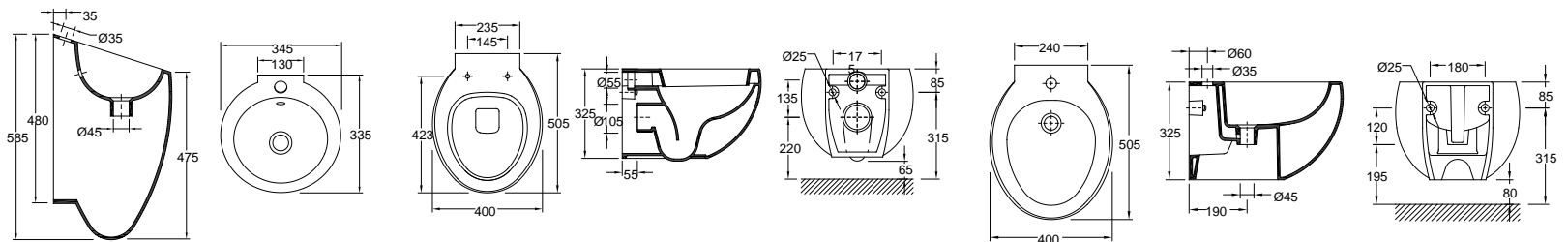

ASSIMÉTRICA pag.14

Lavatório | washbasin | lavabo

Bacia | WC | WC

Bidé | bidet | bidet

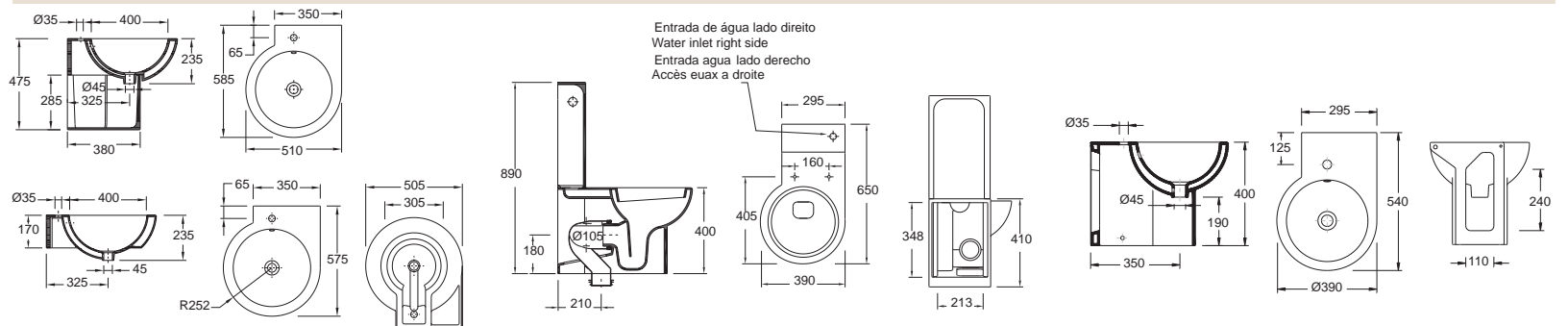

LIGHT pag.16

Lavatório | washbasin | lavabo

Bacia | WC | WC

Bidé | bidet | bidet

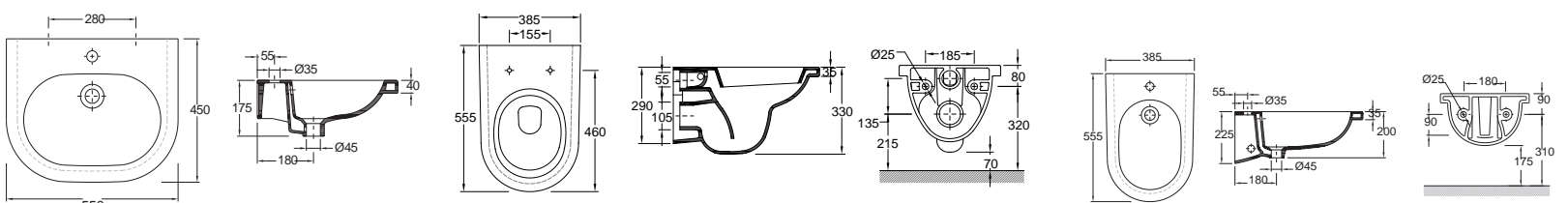

DESENHOS TÉCNICOS | TECHNICAL DRAWING | DESSINS TECHNIQUES

NAUTILUS pag.18

Lavatório | washbasin | lavabo

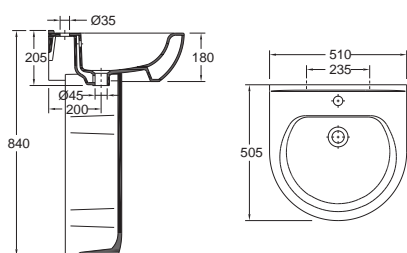

Bacia | WC | WC

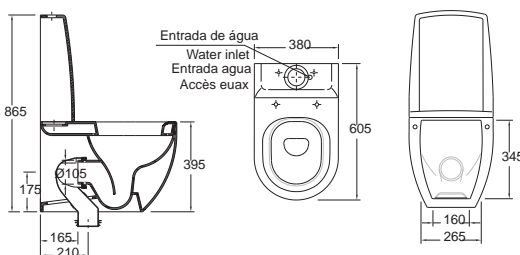

Bidé | bidet | bidet

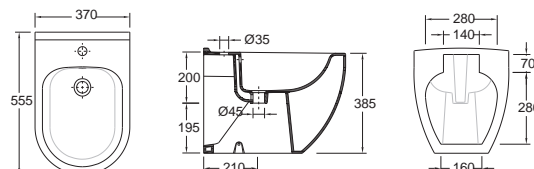

NAUTILUS SUSPENSO | NAUTILUS HUNG WALL SET | NAUTILUS SUSPENDU pag.20

Lavatório | washbasin | lavabo

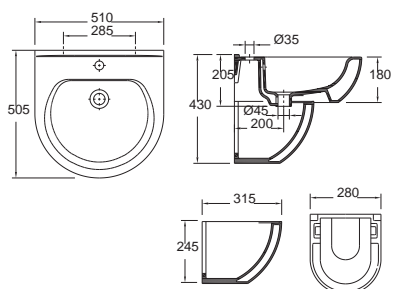

Bacia | WC | WC

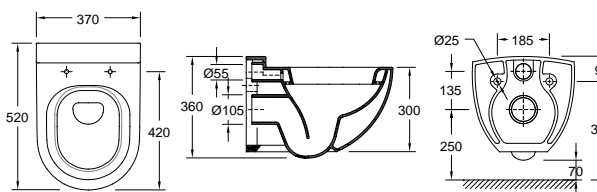

Bidé | bidet | bidet

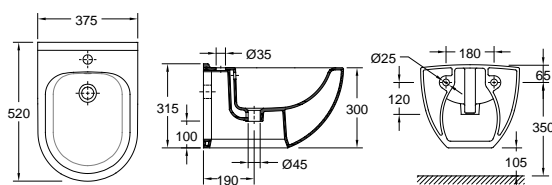

OPORTO pag.22

Lavatório | washbasin | lavabo

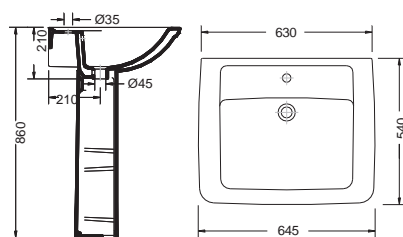

Bacia | WC | WC

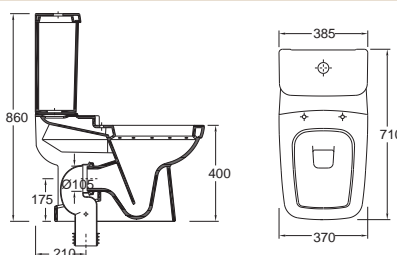

Bidé | bidet | bidet

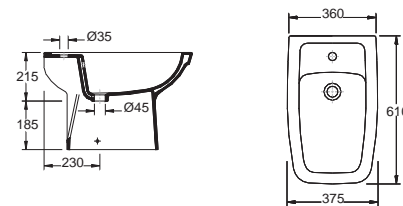

NEOCLASSICA pag.24

Lavatório | washbasin | lavabo

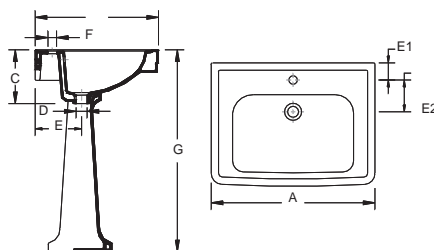

Bacia | WC | WC

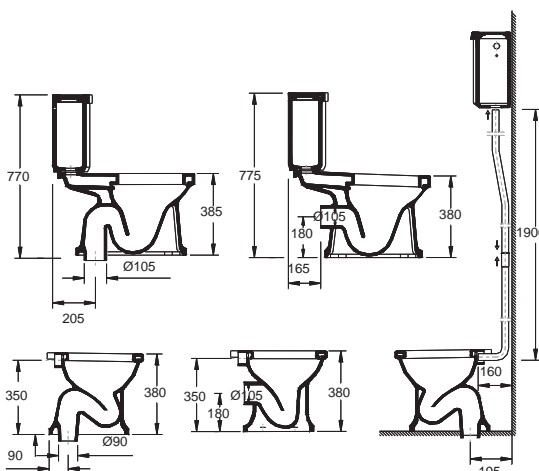

Bidé | bidet | bidet

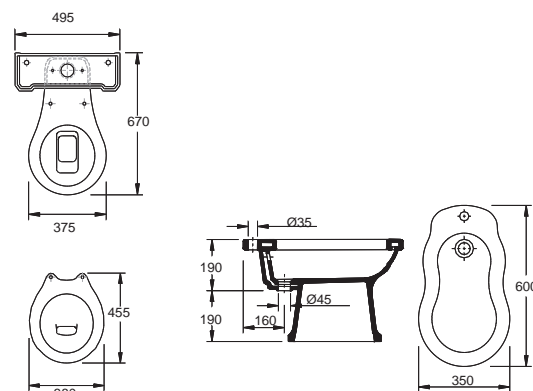

DIMENSÕES DIMENSIONS DIMENTIONS	A	B	C	D	E	E1	E2	F	G
MÉDIO MOYEN MEDIUM	615	505	230	45	200	70	130	35	820
NORMAL NORMAL NORMALE	670	505	225	45	200	70	130	35	830

DESENHOS TÉCNICOS | TECHNICAL DRAWING | DESSINS TECHNIQUES

TAGUS pag.26

Lavatório | washbasin | lavabo

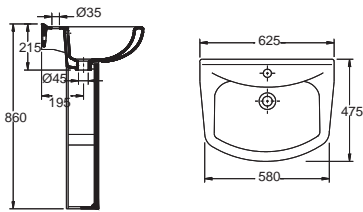

Bacia | WC | WC

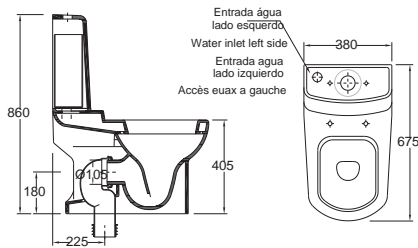

Bidé | bidet | bidet

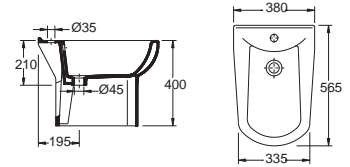

DURIUS pag.28

Lavatório | washbasin | lavabo

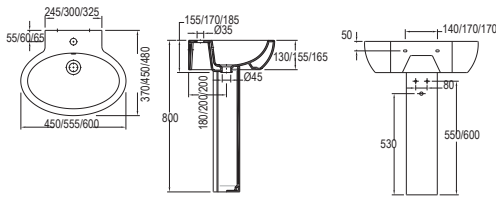

Bacia | WC | WC

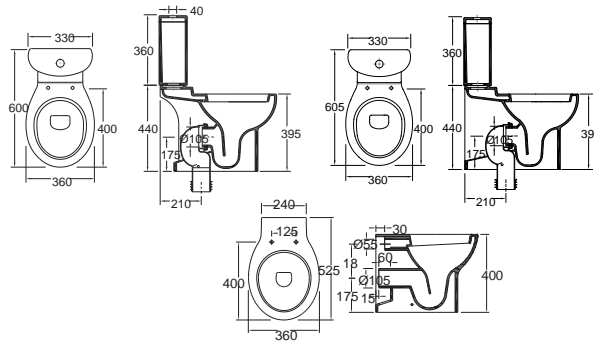

Bidé | bidet | bidet

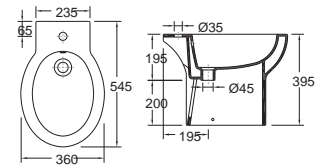

DURIUS SUSPENSO | DURIUS HUNG WALL SET | DURIUS SUSPENDU pag.30

Lavatório | washbasin | lavabo

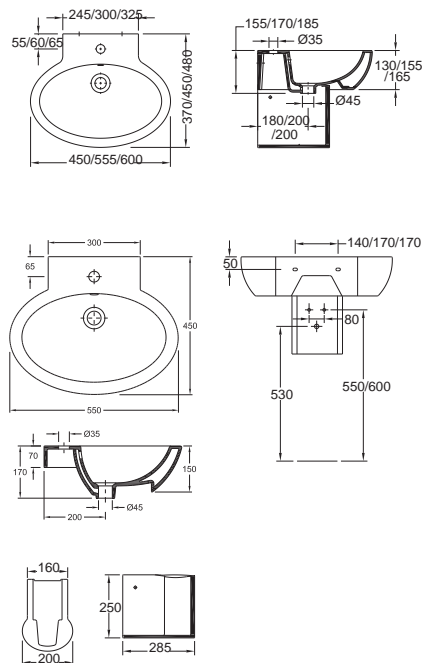

Bacia | WC | WC

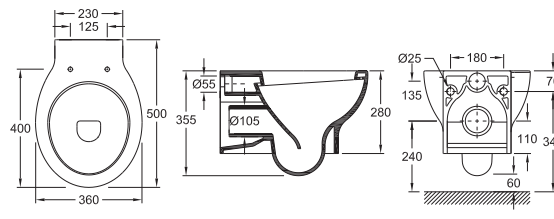

Bidé | bidet | bidet

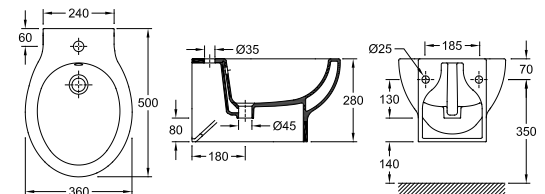

DESENHOS TÉCNICOS | TECHNICAL DRAWING | DESSINS TECHNIQUES

OPUS pag.32

Lavatório | washbasin | lavabo

Bacia | WC | WC

Bidé | bidet | bidet

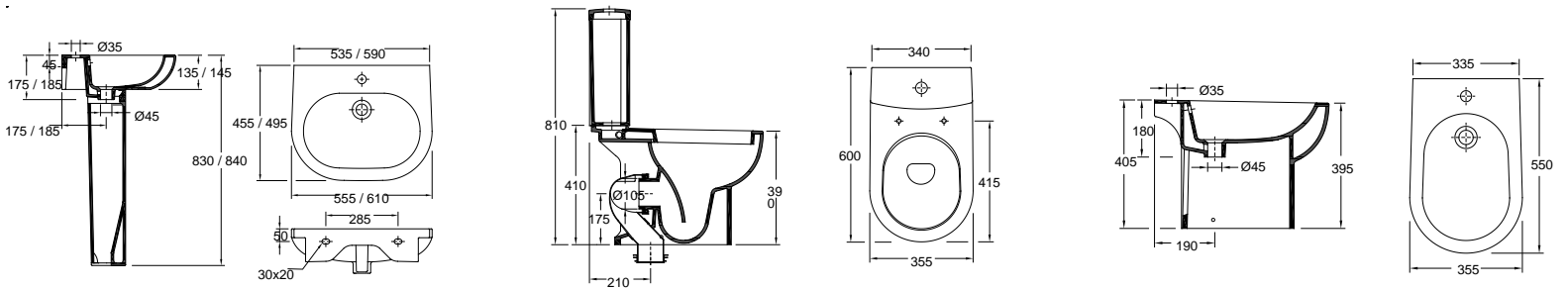

OPUS SUSPENSO | OPUS WALL HUNG | OPUS SUSPENDU pag.34

Lavatório | washbasin | lavabo

Bacia | WC | WC

Bidé | bidet | bidet

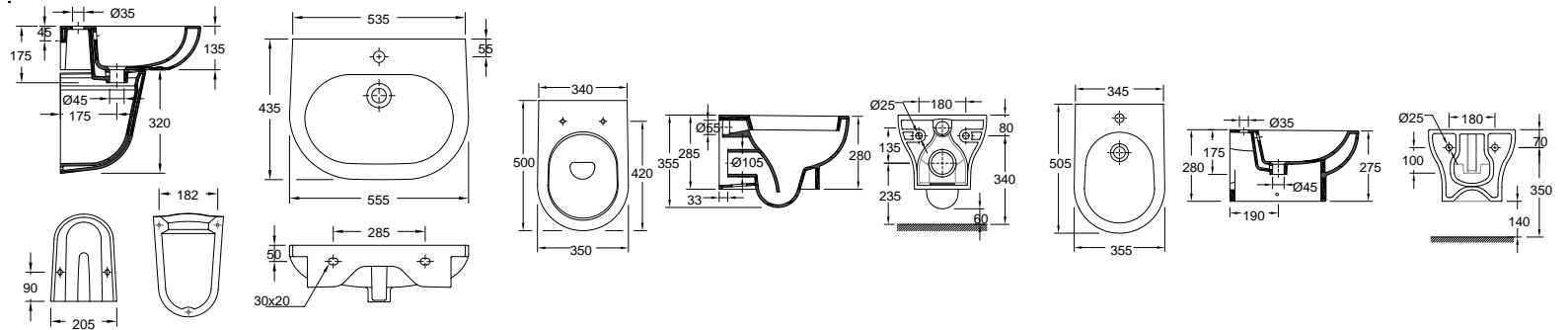

EUROPA PLUS pag.36

Lavatório | washbasin | lavabo

Bacia | WC | WC

Bidé | bidet | bidet

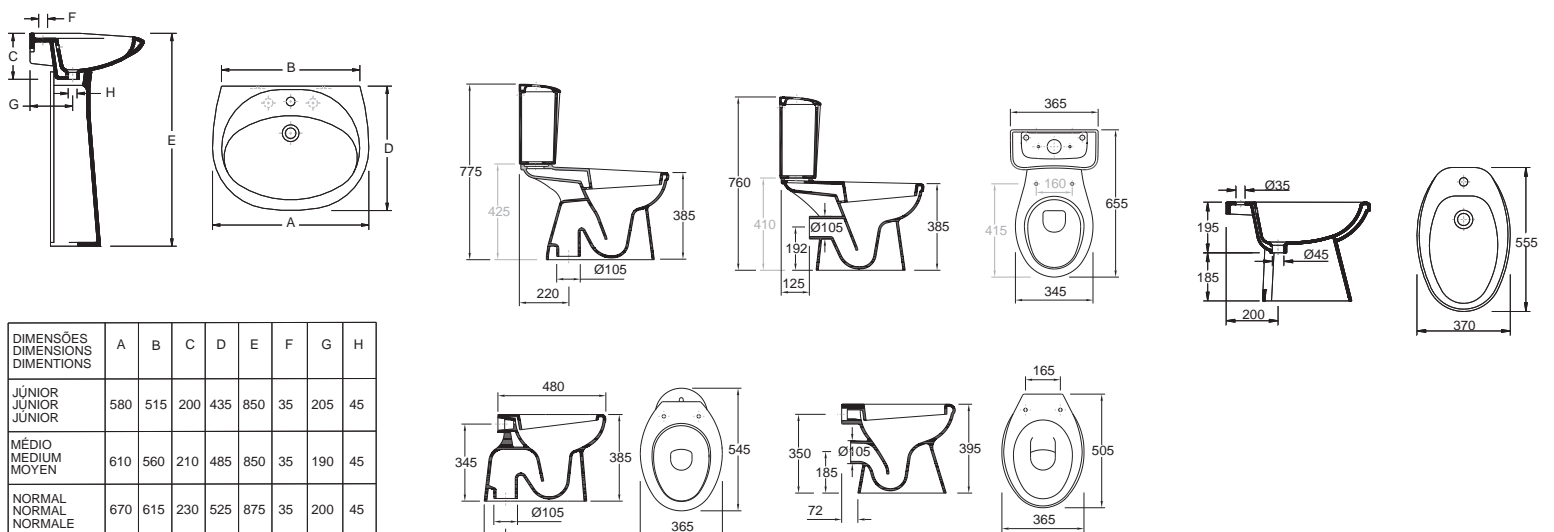

DESENHOS TÉCNICOS | TECHNICAL DRAWING | DESSINS TECHNIQUES

EUROPA SUSPENSO | EUROPA WALL HUNG | EUROPA SUSPENDU pag.38

Lavatório | washbasin | lavabo

Bacia | WC | WC

Bidê | bidet | bidet

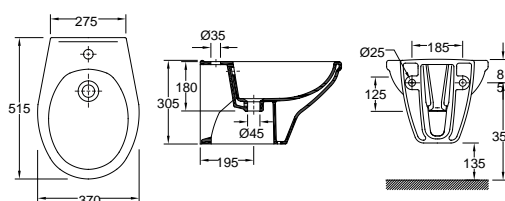
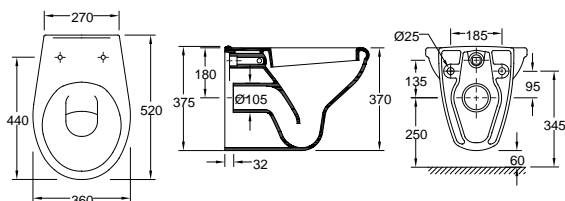
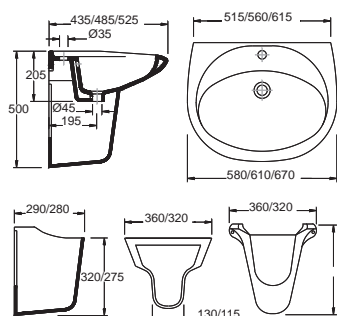

V-JUNIOR pag.40

Lavatório | washbasin | lavabo

Bacia | WC | WC

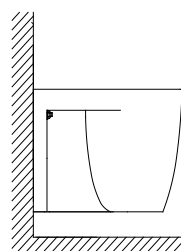
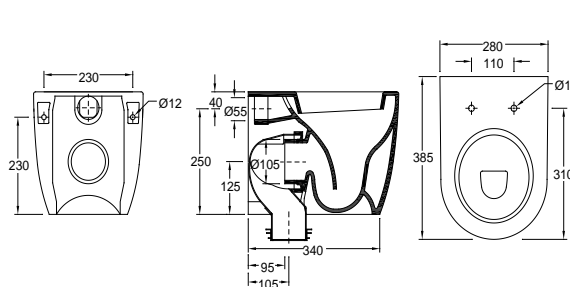
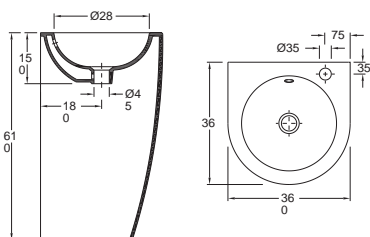

MEDIDAS DE INSTALAÇÃO ACONSELHADAS		
	A	B
V-JUNIOR	290	60

Nota: Esta Sanita pode ser instalada "Suspensa" sem estrutura conforme as medidas aconselhadas

INFANTIL pag.42

Lavatório | washbasin | lavabo

Bacia | WC | WC

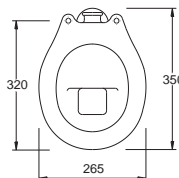
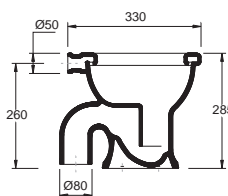
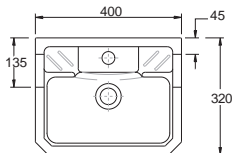
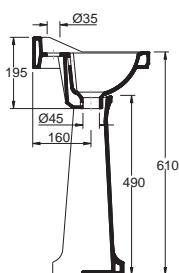

PMR | HANDICAP | HANDICAPÉ | PMR pag.44

Lavatório | washbasin | lavabo

Bacia | WC | WC

Bacia suspensa | Wall hung WC
WC suspendu

Base de Chuveiro | Shower Tray
Bac douche

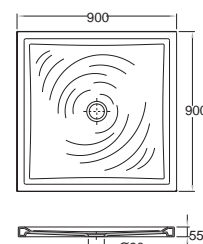
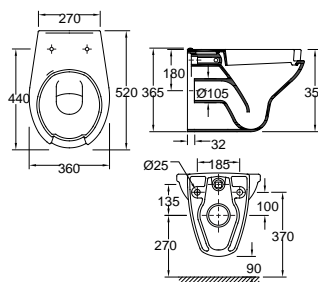
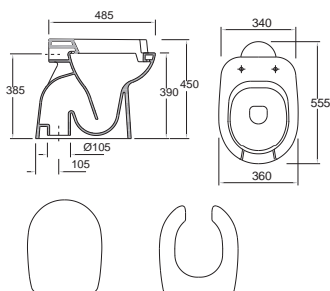
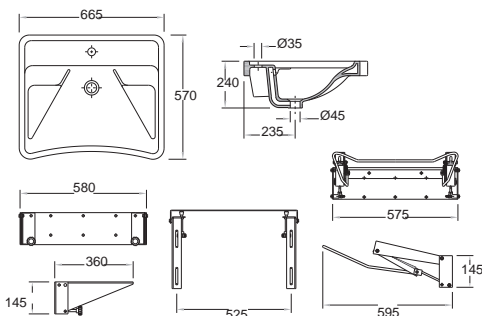

DESENHOS TÉCNICOS | TECHNICAL DRAWING | DESSINS TECHNIQUES

COMPLEMENTOS PMR | HANDICAP SET ACCESSORIES | COMPLÉMENTS POUR WC HANDICAPÉ pag.46

Monocomando Style para Lavatório | Single lever Style faucet for washbasin | Mitigeur Style pour lavabo

Monocomando Style para banheira | Single lever Style faucet for bathtubs | Mitigeur Style pour baignoire

Monocomando para lavatório | Single lever faucet for washbasin | Mitigeur pour lavabo

Misturadora c/ chuveiro de válvula | High pressure mixer and shower with valve | Mitigeur avec douchete

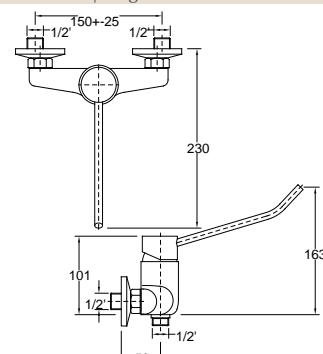
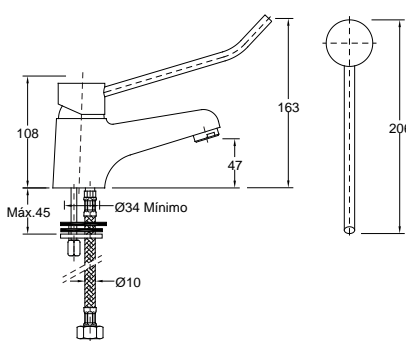
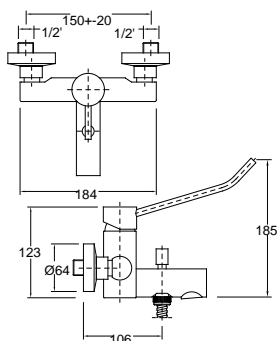
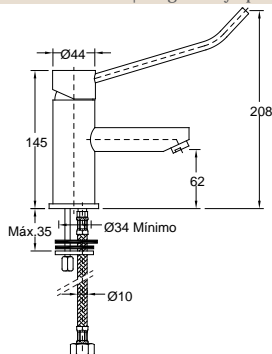

COMPLEMENTOS PMR | HANDICAP SET ACCESSORIES | COMPLÉMENTS POUR WC HANDICAPÉ pag.46 /47

Espelho Basculante | Mirror | Mirroir d'inclinaison réglable

Apoio aço inox | Single support bar Barre simple

Apoio para Lavatório | Washbasin support bar Barre Lavabo

Apoio para sanita | WC support bar Barre WC

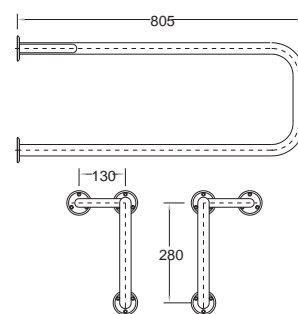
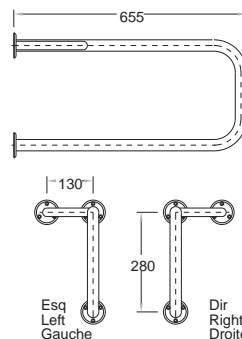
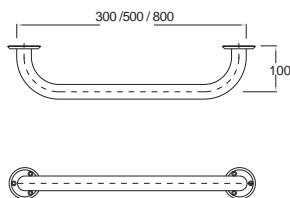
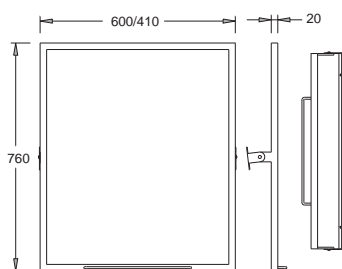

COMPLEMENTOS PMR | HANDICAP SET ACCESSORIES | COMPLÉMENTS POUR WC HANDICAPÉ pag.48

Apoio de sanita basculante | Adjustable support WC | Barre réglable pour WC

Apoio de sanita basculante c/ porta-rolô | Adjustable support for WC with paper holder | Barre de support WC avec support de papier

Apoio de sanita articulado | Articulated WC support | Barre de support articulé pour WC

Banco para chuveiro | Shower Tray | Siège p/ douche

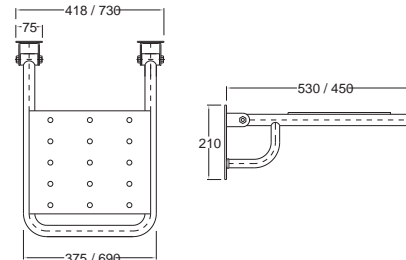
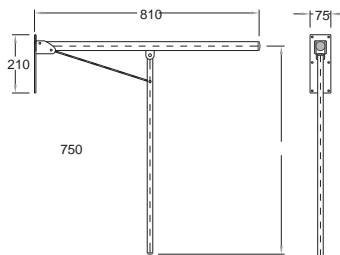
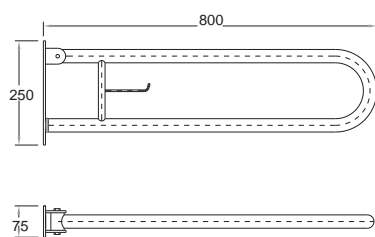
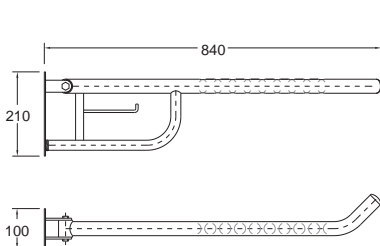

ESTRUTURAS P/ SANITÁRIOS SUSPENSOS | STRUCTURE FOR WALL HUNG | SUPPORT MÉTALLIQUE P/ CUVETTE SUSPENDU pag.49

Estrutura para bacia suspensa dupla descarga 350 mm | Structure for WC wall hung dual flush 350 mm | Support pour cuvette suspendu 350 mm

Estrutura para bacia suspensa dupla descarga | Structure for WC wall hung dual flush | Support pour cuvette suspendu 3/6LT

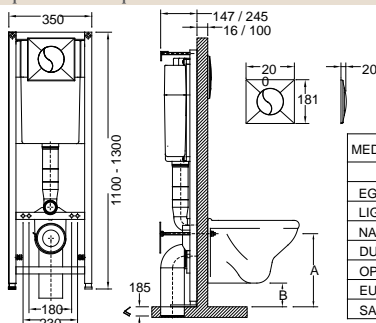

MEDIDAS DE INSTALAÇÃO ACONSELHADAS		
	A	B
EGG	315	65
LIGHT	320	70
NAUTILUS	350	70
DURIUS	340	60
OPUS	340	60
EUROPA	345	60
SANITA PMR	370	90

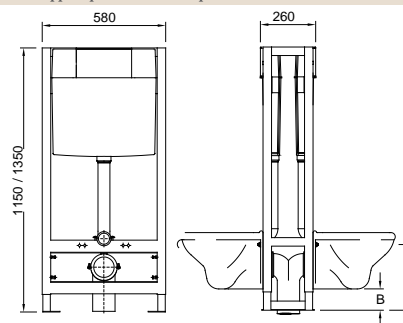

MEDIDAS DE INSTALAÇÃO ACONSELHADAS		
	A	B
EGG	315	65
LIGHT	320	70
NAUTILUS	350	70
DURIUS	340	60
OPUS	340	60
EUROPA	345	60
SANITA PMR	370	90

DESENHOS TÉCNICOS | TECHNICAL DRAWING | DESSINS TECHNIQUES

ESTRUTURAS PARA SANITÁRIOS SUSPENSOS | STRUCTURE FOR WALL HUNG | SUPPORT MÉTALLIQUE P/ CUVETTE SUSPENDU pag.49 /

Estrutura metálica p/ lavatório suspenso c/ curva de esgoto | Metallic structure for wall mounting washbasin with outlet pipe | Support Métallique pour cuvette suspendu

Estrutura p/ sanita suspenso s/ tanque c/ curva de esgoto | Wall mounted structure for wall hung wc, with no cistern | Support métallique p/ cuvette suspendu, mécanisme 3/6 LT

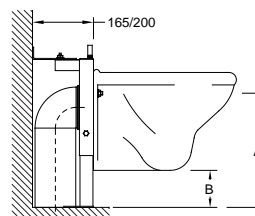
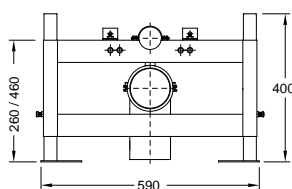
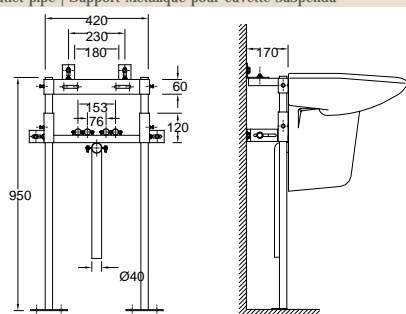

MEDIDAS DE INSTALAÇÃO ACONSELHADAS		
	A	B
EGG	315	65
LIGHT	320	70
NAUTILUS	350	70
DURIUS	340	60
OPUS	340	60
EUROPA	345	60
SANITA PMR	370	90

ESTRUTURAS PARA SANITÁRIOS SUSPENSOS | STRUCTURE FOR WALL HUNG | SUPPORT MÉTALLIQUE P/ CUVETTE SUSPENDU pag.50

Est. p/ bidê suspenso 400 mm | Structure for wall hung bidet 400 mm | Support pour bidet suspendu 400 mm

Estrutura metálica de encastrar pré-montada p/ bidê suspenso c/ curva de esgoto | Wall mounted structure for wall hung wc, with cistern, with trap | Support Métallique P/Cuvette suspendu avec réservoir

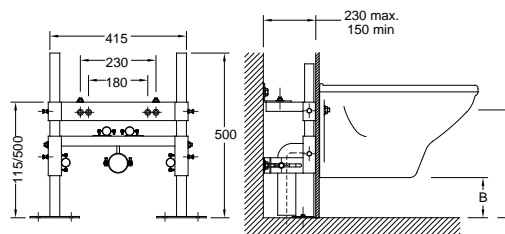
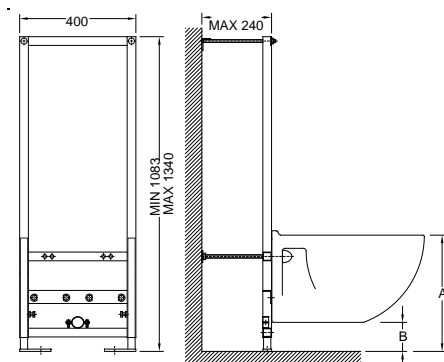

MEDIDAS DE INSTALAÇÃO ACONSELHADAS		
	A	B
EGG	315	80
LIGHT	310	175
NAUTILUS	350	105
DURIUS	350	140

MEDIDAS DE INSTALAÇÃO ACONSELHADAS		
	A	B
EGG	315	80
LIGHT	310	175
NAUTILUS	350	105
DURIUS	350	140
OPUS	350	140
EUROPA	355	135

ESTRUTURAS PARA SANITÁRIOS SUSPENSOS | STRUCTURE FOR WALL HUNG | SUPPORT MÉTALLIQUE P/ CUVETTE SUSPENDU pag.51

Est. met. dupla encastrar pré-montada p/ 2 bidês susp. c/ curva de esgoto | Wall mounted structure for wall hung wc, with no cistern | Support Métallique double encastrer pour 2 bidêt suspendu

Estrutura de instalação para urinol com fluxômetro FLUXO | Structure for urinal with flowmeter Fluxo | Support pour urinoir avec fluxomètre Fluxo

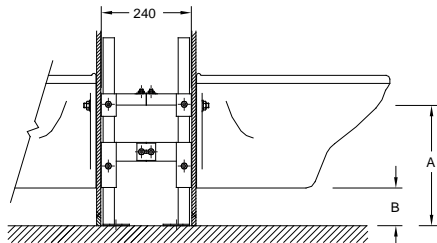
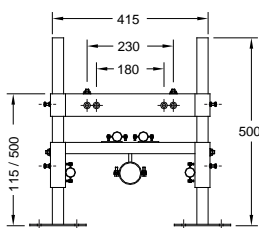

MEDIDAS DE INSTALAÇÃO ACONSELHADAS		
	A	B
EGG	315	80
LIGHT	310	175
NAUTILUS	350	105
DURIUS	350	140
OPUS	350	140
EUROPA	355	135

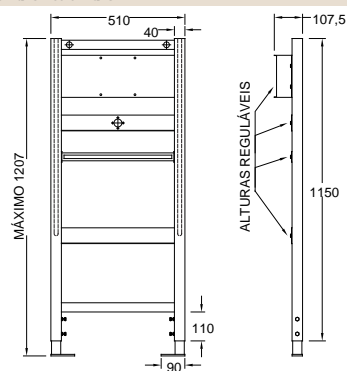

DESENHOS TÉCNICOS | TECHNICAL DRAWING | DESSINS TECHNIQUES

URINÓIS | URINALS | URINOIRS pag.53 / 55

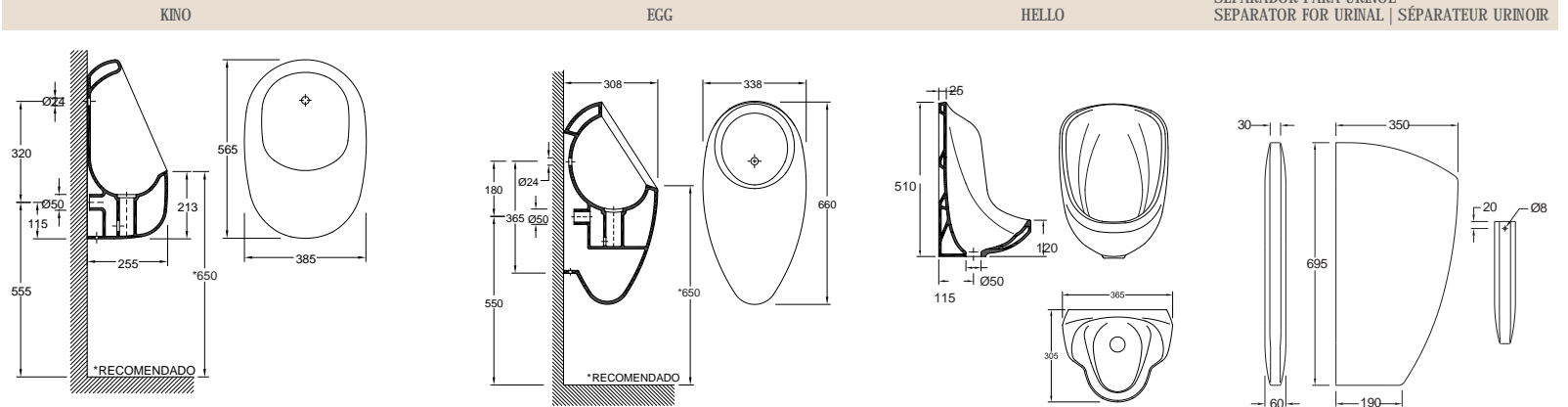

URINÓIS | URINALS | URINOIRS pag.55

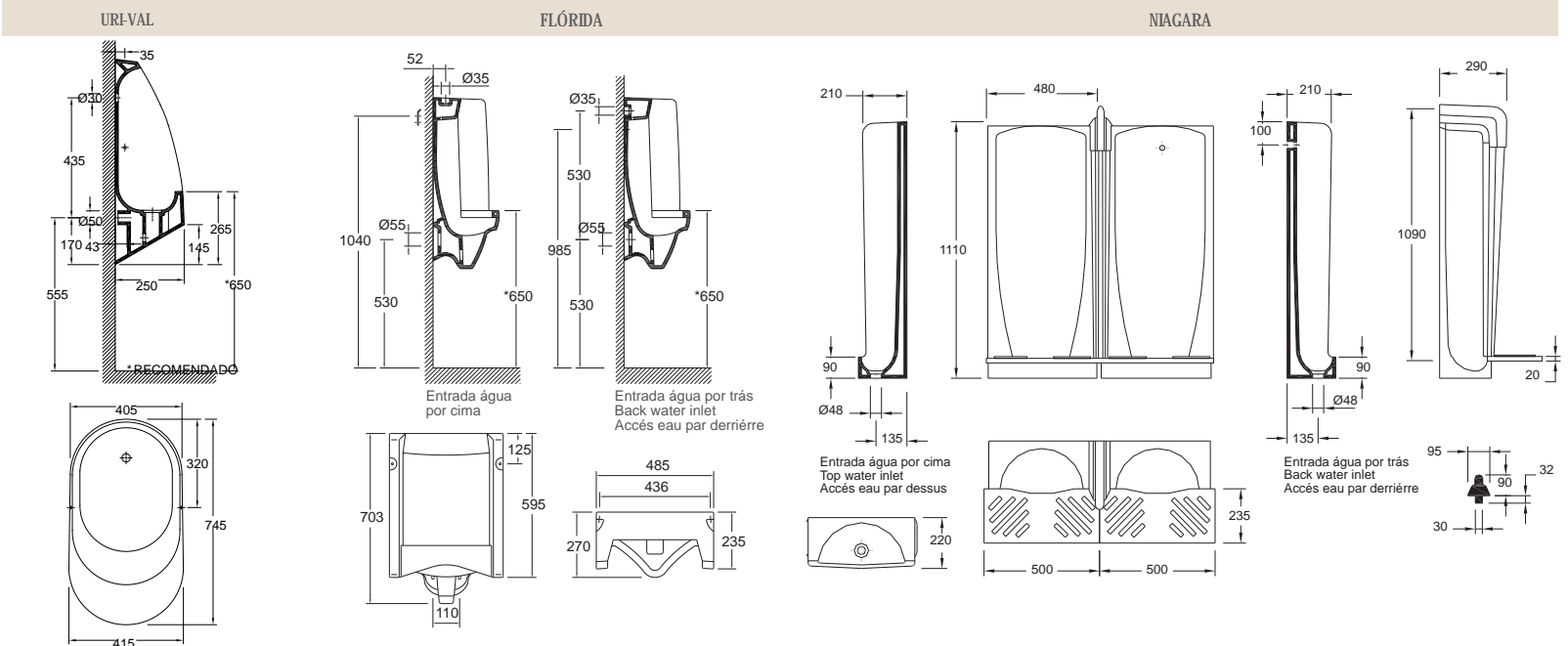

URINÓIS | URINALS | URINOIRS pág.56

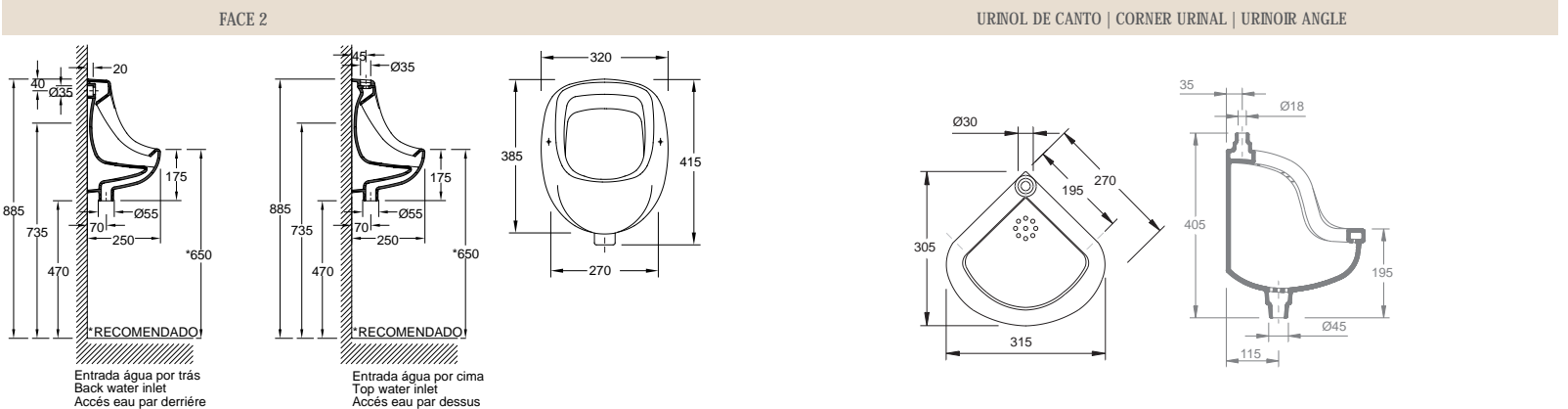

DESENHOS TÉCNICOS | TECHNICAL DRAWING | DESSINS TECHNIQUES

LAVATÓRIOS | WASHBASINS | LAVABOS pag.57 / 58

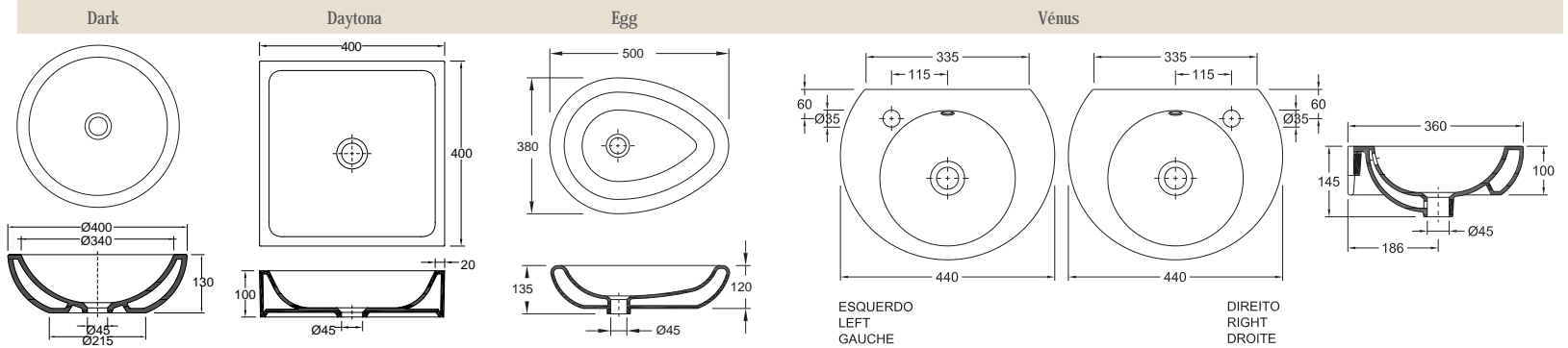

LAVATÓRIOS | WASHBASINS | LAVABOS pag.58 / 59

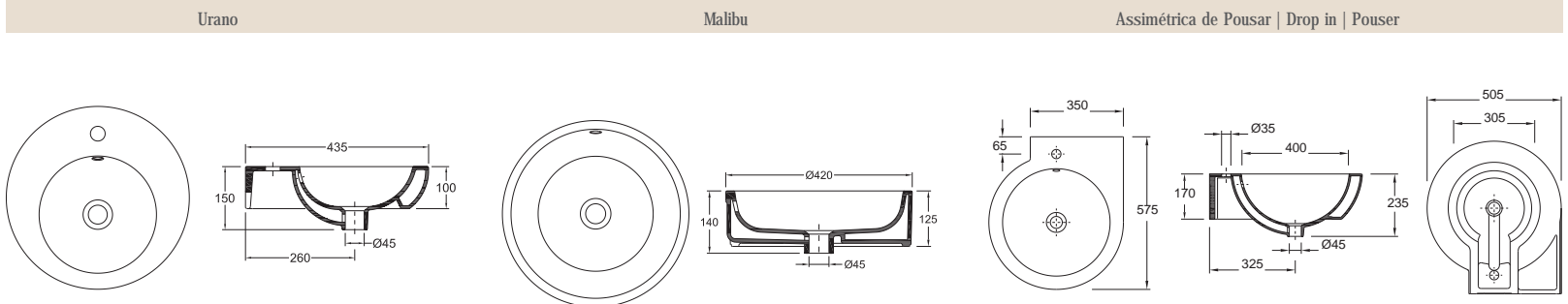

LAVATÓRIOS | WASHBASINS | LAVABOS pag.59 / 60

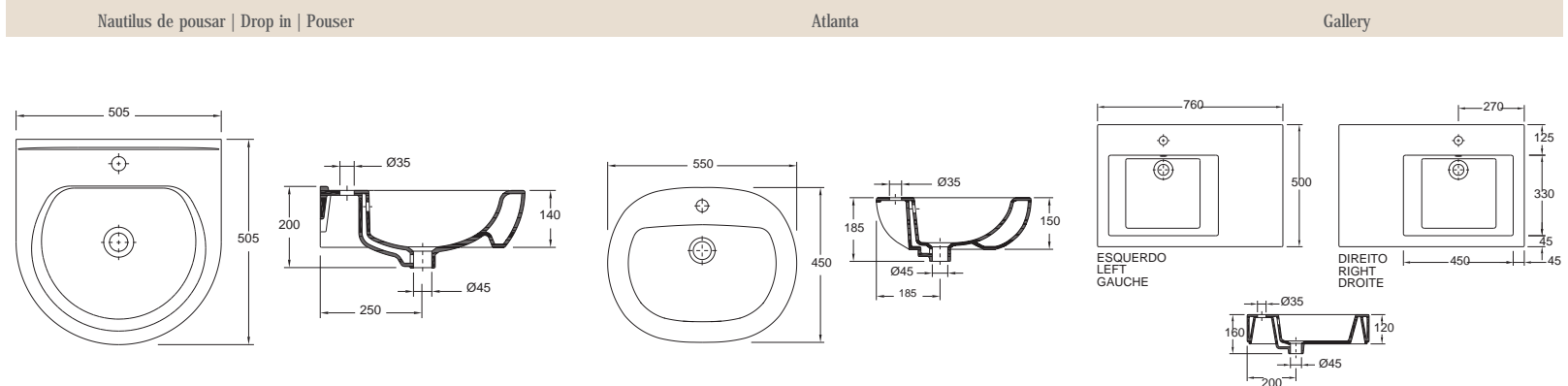

LAVATÓRIOS | WASHBASINS | LAVABOS pag.60

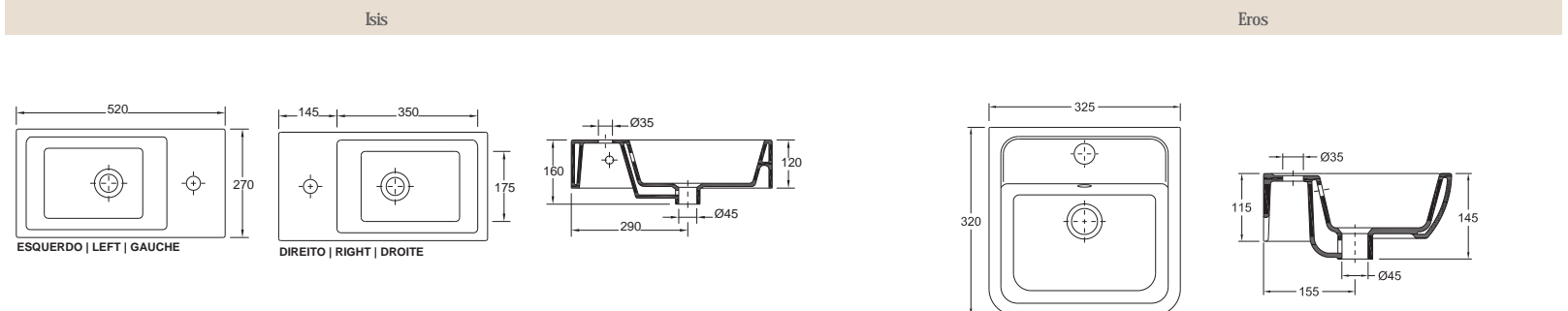

DESENHOS TÉCNICOS | TECHNICAL DRAWING | DESSINS TECHNIQUES

LAVATÓRIOS | WASHBASINS | LAVABOS pag.61

Miami

Boston

Ceuta

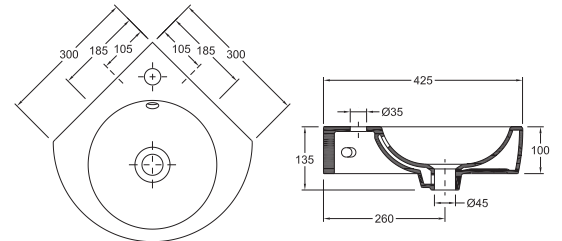
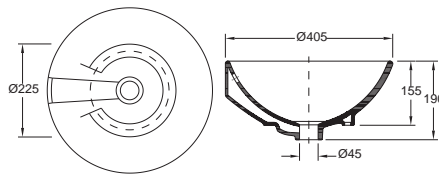
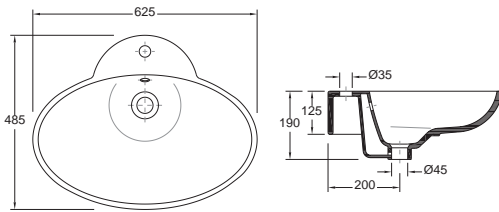

LAVATÓRIOS | WASHBASINS | LAVABOS pag.62

Recife Plus

Rio

Búzios

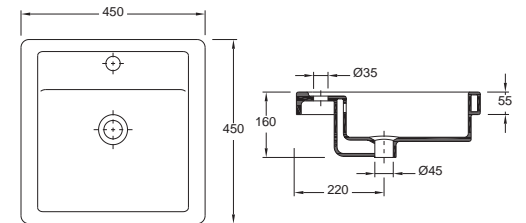
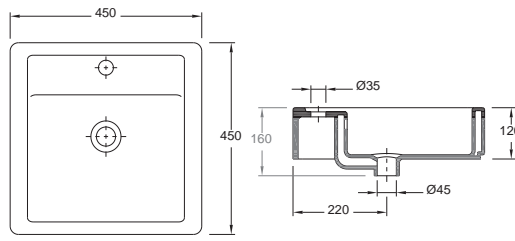
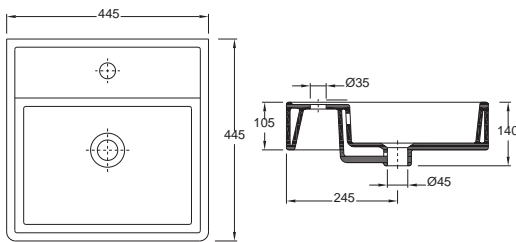

LAVATÓRIOS | WASHBASINS | LAVABOS pag.63

Roma

Torino

Missouri

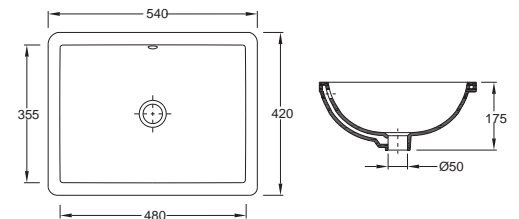
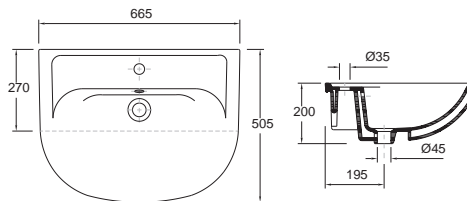
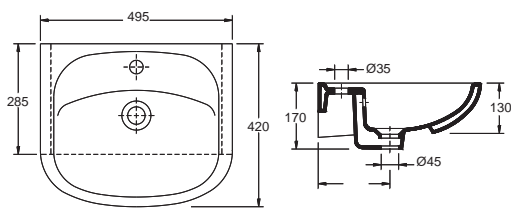

LAVATÓRIOS | WASHBASINS | LAVABOS pag.64

Tanger

Oval

Elipse

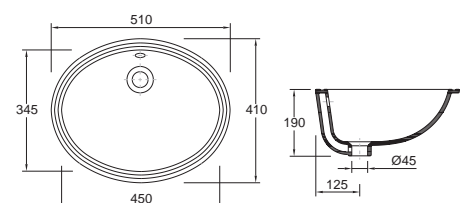
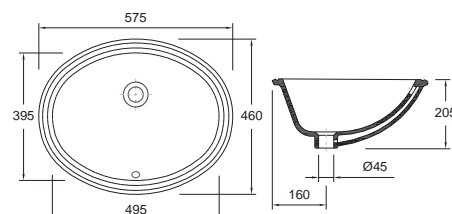
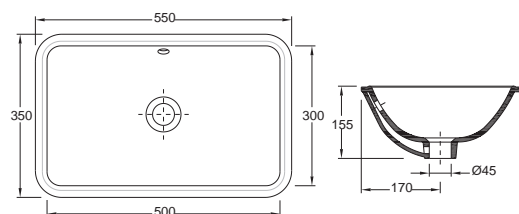

DESENHOS TÉCNICOS | TECHNICAL DRAWING | DESSINS TECHNIQUES

LAVATÓRIOS | WASHBASINS | LAVABOS pag.65

Danúbio

Nice

Miramar

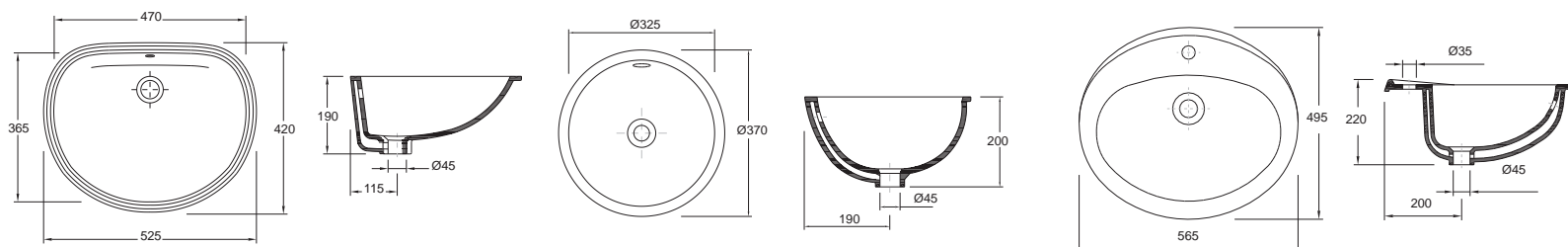

LAVATÓRIOS | WASHBASINS | LAVABOS pag.66

Brava

Nilo

Oasis

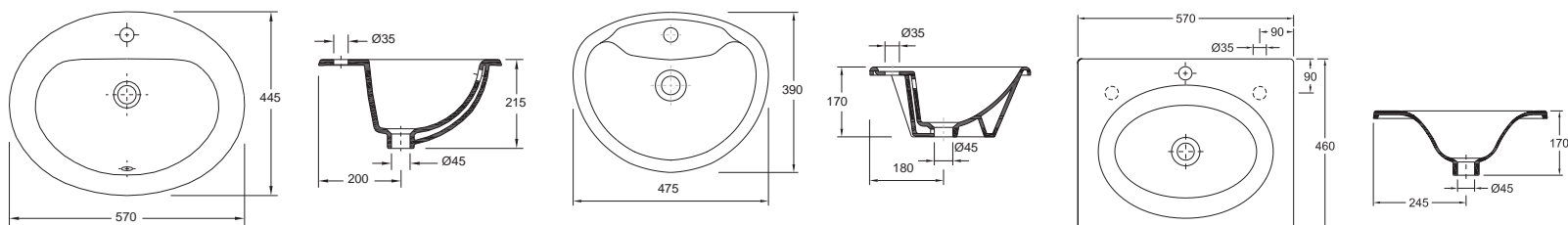

LAVATÓRIOS | WASHBASINS | LAVABOS pag.67

Mónaco

Goa

Palm

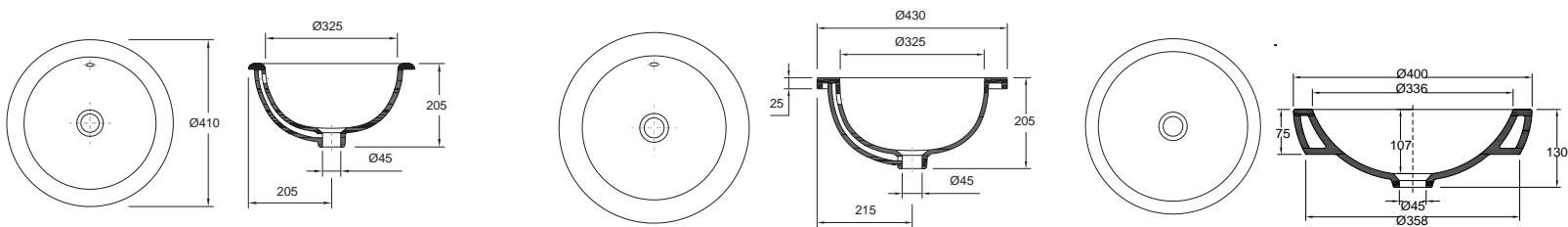

LAVATÓRIOS | WASHBASINS | LAVABOS pag.68

Top

Móvel | Cupboard | Meuble Top

Top Plus

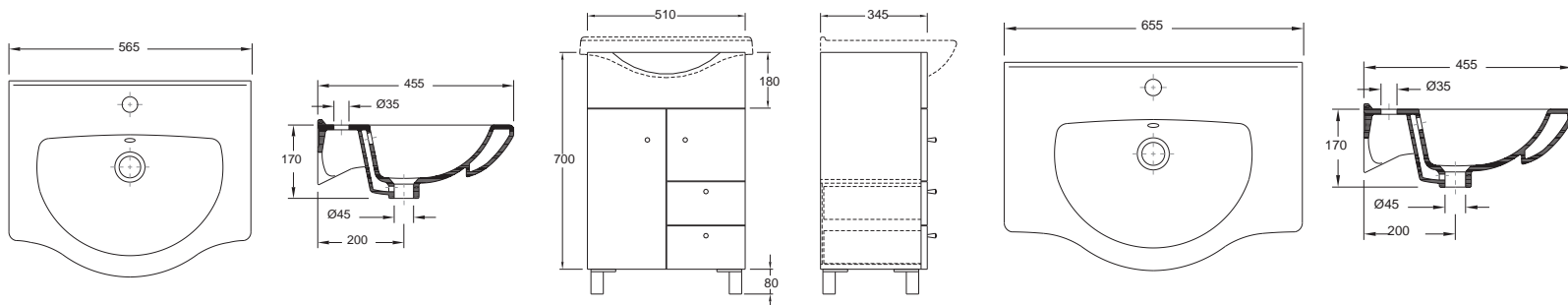

DESENHOS TÉCNICOS | TECHNICAL DRAWING | DESSINS TECHNIQUES

PLACA CERÂMICA | CERAMIC TOP | TABLETTE PORCELAINE pag.68 / 69

Móvel | Cupboard | Meuble Top Plus

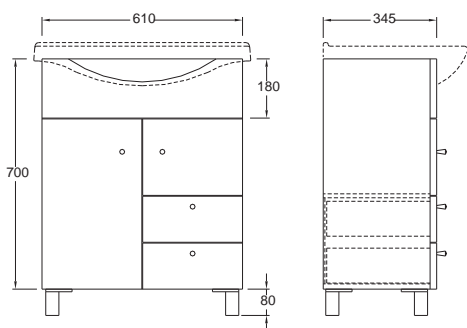

Placa cerâmica | Ceramic Top | Tablette Porcelaine

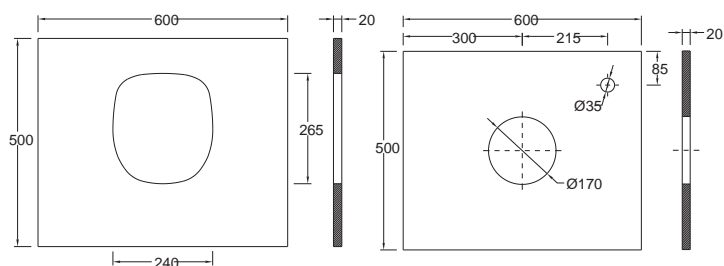

PLACA CERÂMICA | CERAMIC TOP | TABLETTE PORCELAINE pag.69

Placa cerâmica | Ceramic Top | Tablette Porcelaine

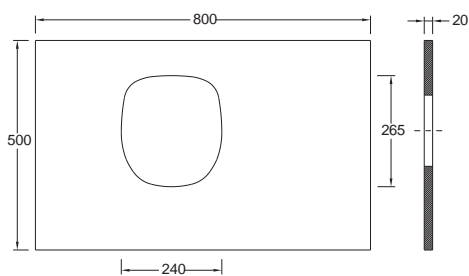

Placa cerâmica | Ceramic Top | Tablette Porcelaine

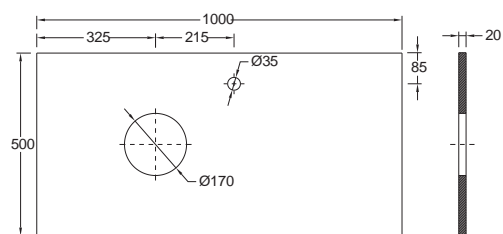
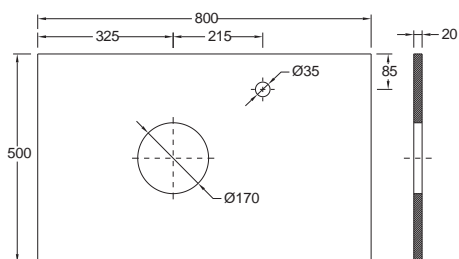
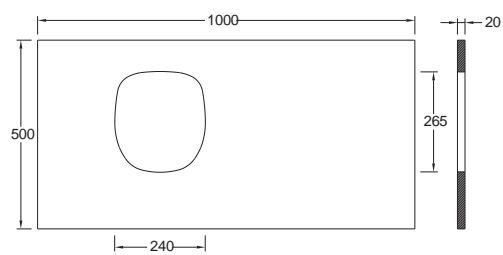

MÓVEIS | FURNITURE | MEUBLES pag.70

IKO (60cm) Móvel p/ Placa cerâmica | Cupboard Ceramic Top | Meuble Tablette Porcelaine

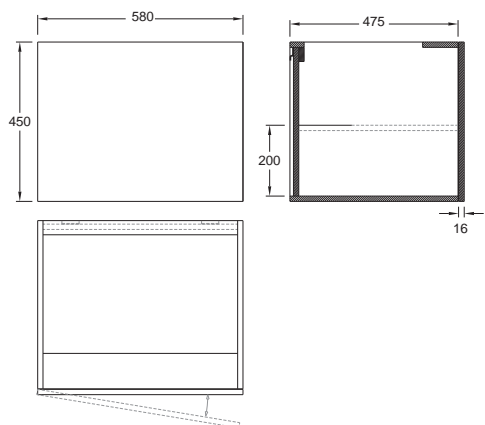

IKO (80cm | 100cm) Móvel p/ Placa cerâmica | Cupboard Ceramic Top | Meuble Tablette Porcelaine

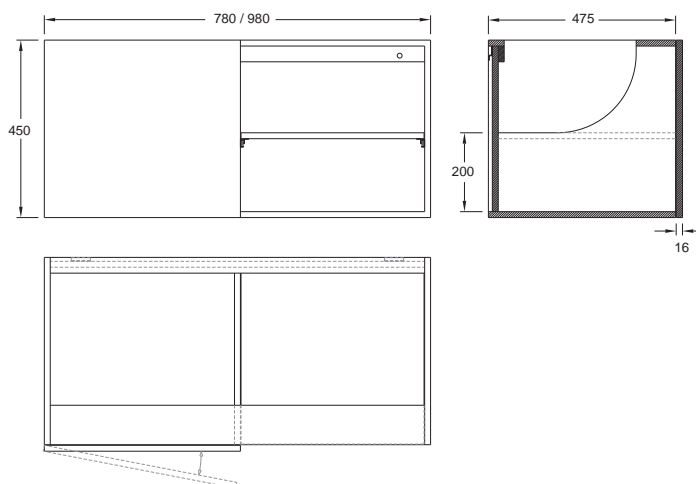

DESENHOS TÉCNICOS | TECHNICAL DRAWING | DESSINS TECHNIQUES

LAVATÓRIOS | WASHBASINS | LAVABOS pag.71 / 72

Platinum 60cm | 80cm | 90cm | 100cm | 120cm

OKI (60cm | 80cm | 90cm | 100cm | 120cm)
Móvel | Cupboard | Meuble

Móvel ISIS | Cupboard | Meuble

Sifão | Siphon | Siphon

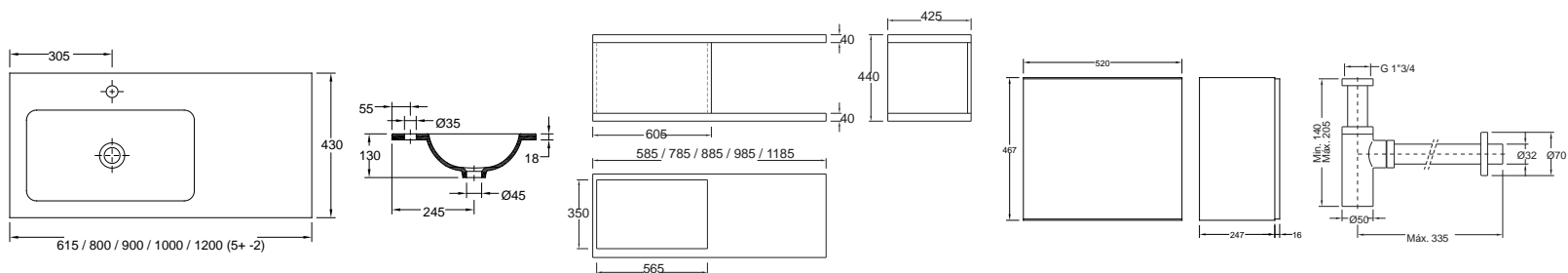

PEÇAS TÉCNICAS | TECHNICAL PIECES | PIÈCES TECHNIQUES pag. 73

Monchique

Sintra

Silves

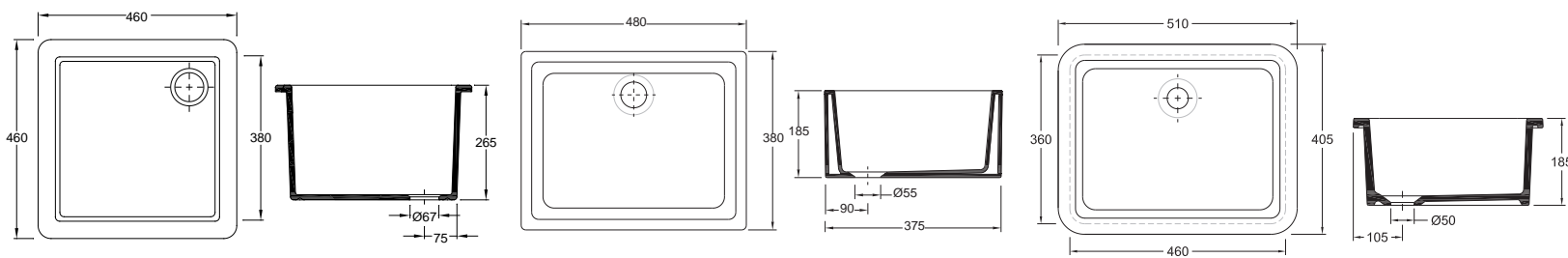

PEÇAS TÉCNICAS | TECHNICAL PIECES | PIÈCES TECHNIQUES pag.73 / 74

Lava mãos | Hand washbasin | Lave-Mains

Pia Hospitalar | Medical slop hopper Évier hospital

Bacia | wc | wc BTW

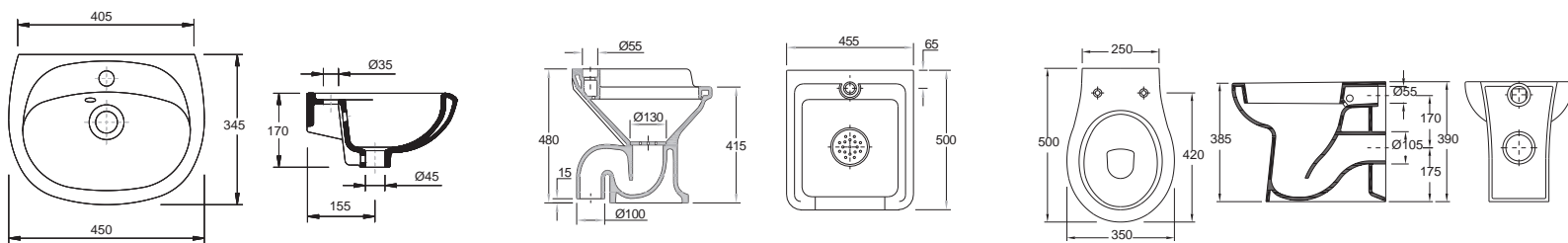

PEÇAS TÉCNICAS | TECHNICAL PIECES | PIÈCES TECHNIQUES pag.74

Bacia Turca | Squatting WC Pan | WC Turc

Mozela

Móvel | Cupboard | Meuble Mozela

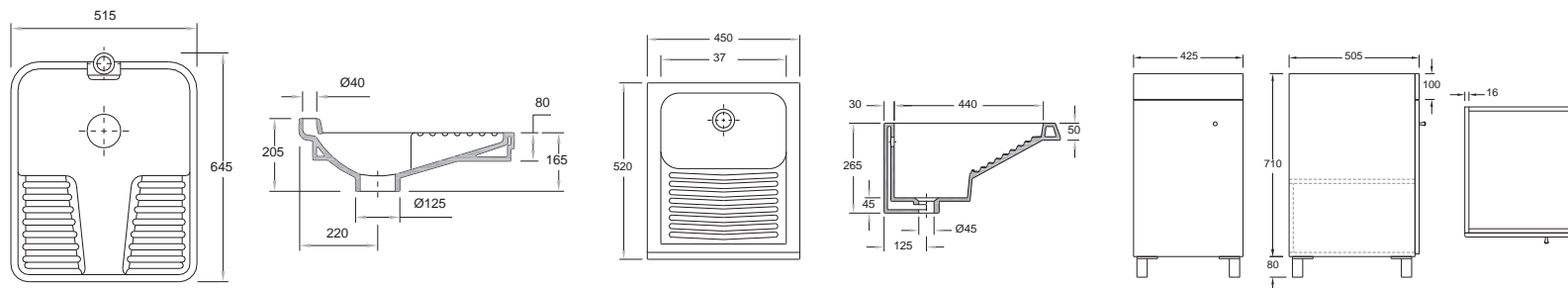

DESENHOS TÉCNICOS | TECHNICAL DRAWING | DESSINS TECHNIQUES

BASES DE CHUVEIRO | SHOWER TRAYS | BACS À DOUCHE pag.76 / 77

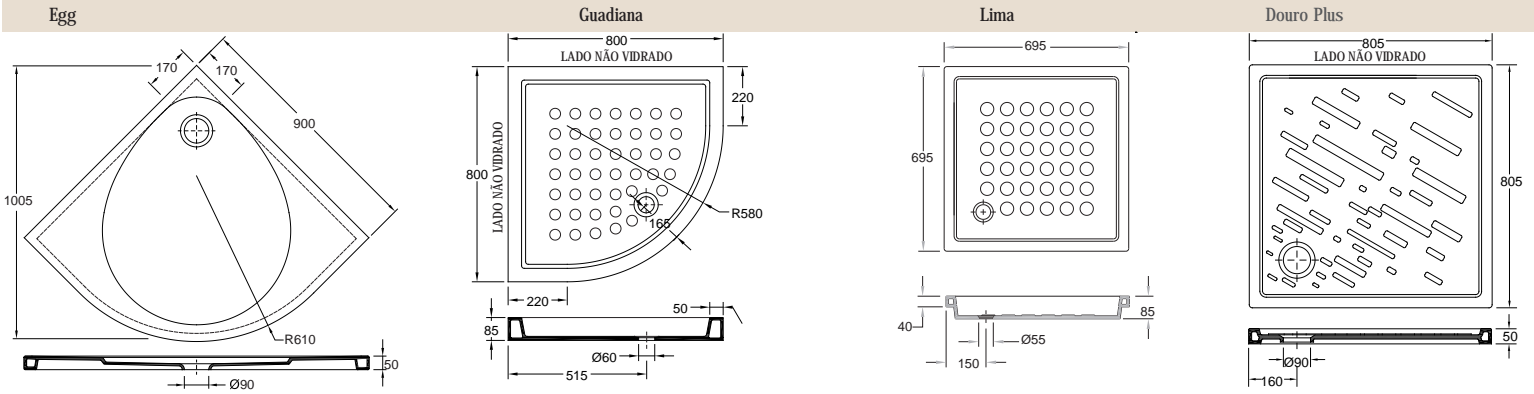

BASES DE CHUVEIRO | SHOWER TRAYS | BACS À DOUCHE pag.77 / 78

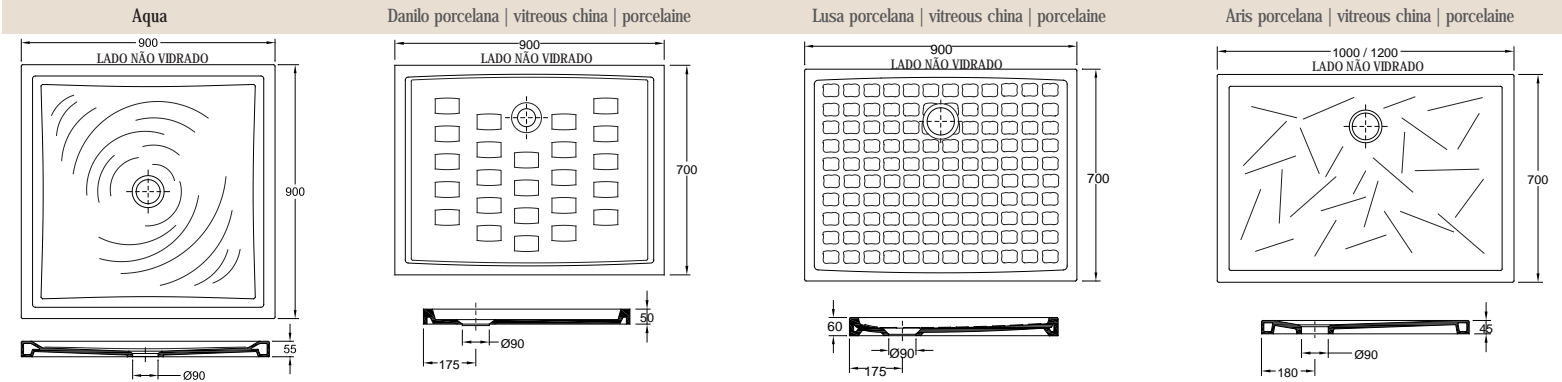

BASES DE CHUVEIRO | SHOWER TRAYS | BACS À DOUCHE pag.79 / 81

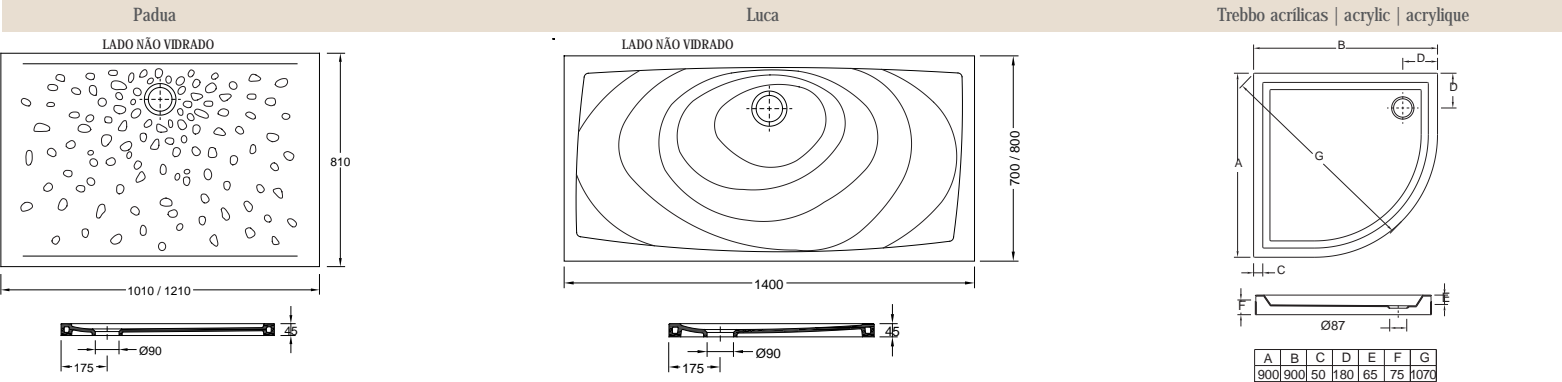

BASES DE CHUVEIRO | SHOWER TRAYS | BACS À DOUCHE pag.81 / 82

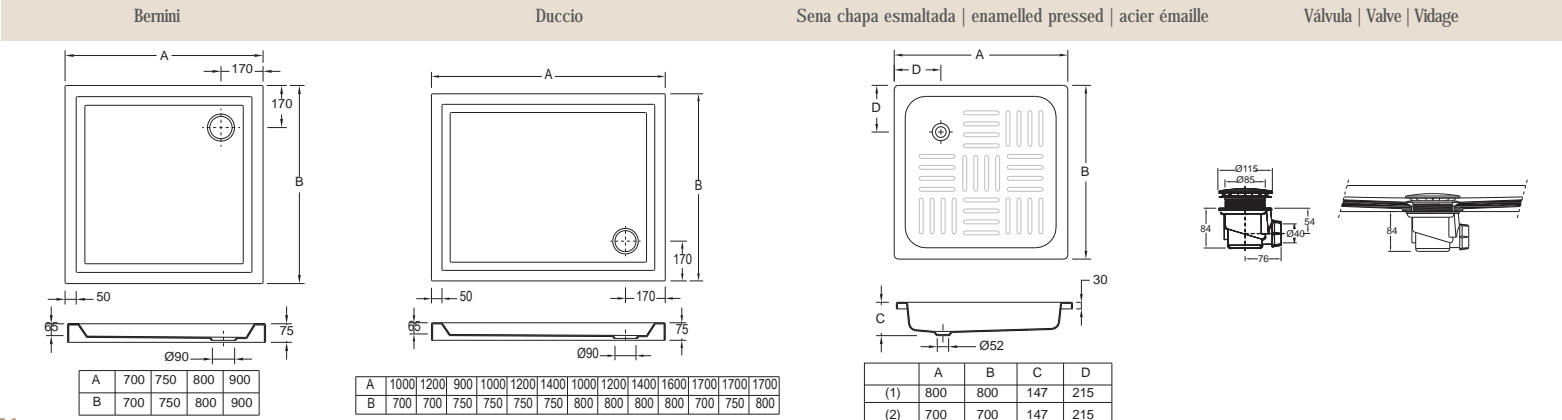

DESENHOS TÉCNICOS | TECHNICAL DRAWING | DESSINS TECHNIQUES

BANHEIRAS ACRILICAS | BATHTUBS ACRYLICS | BAIGNOIRES ACRYLIQUES pag.84 / 85

Sesimbra

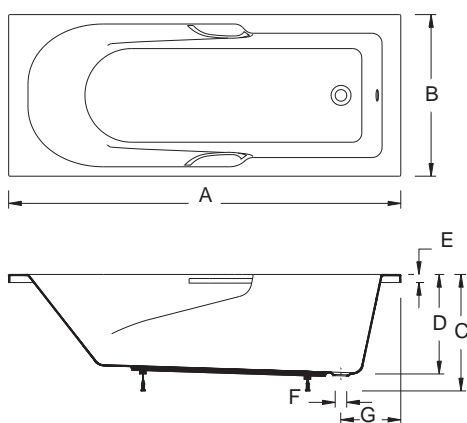

DIMENSÕES DIMENSIONS DIMENSIONS DIMENSIONES		
A	1595	1695
B	700	700
C	MAX 630 / MIN 530	MAX 630 / MIN 530
D	390	390
E	35	35
F	Ø52	Ø52
G	220	220

COTAS COAT COTTE COTAS	TOLERÂNCIAS MARGIN TOLERANCE TOLERANCIAS
> 1000	+5 -10
< 1000	+5 -5
EN 198	

Linea

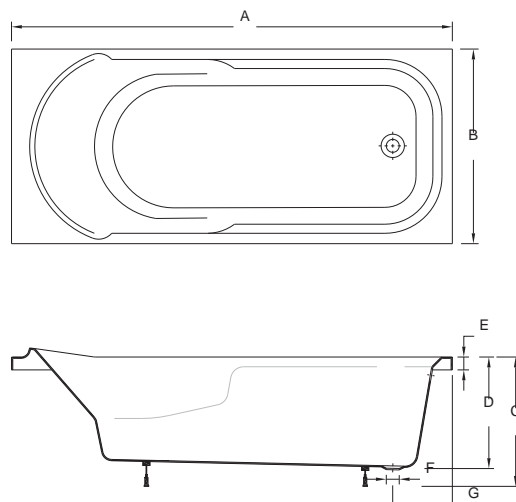

DIMENSÕES DIMENSIONS DIMENSIONS DIMENSIONES				
Mod	1600x750	1700x750	1700x800	
A	1600	1700	1700	1800
B	750	750	800	800
C	MAX 725 / MIN 550	MAX 725 / MIN 550	MAX 725 / MIN 550	MAX 725 / MIN 550
D	410	410	410	410
E	50	50	50	50
F	Ø51	Ø51	Ø51	Ø51
G	230	230	230	230

COTAS COAT COTTE COTAS	TOLERÂNCIAS MARGIN TOLERANCE TOLERANCIAS
> 1000	+5 -10
< 1000	+5 -5
CONFORME NORMA EN 198	

BANHEIRAS ACRILICAS | BATHTUBS ACRYLICS | BAIGNOIRES ACRYLIQUES pag.86 / 87

Pacific

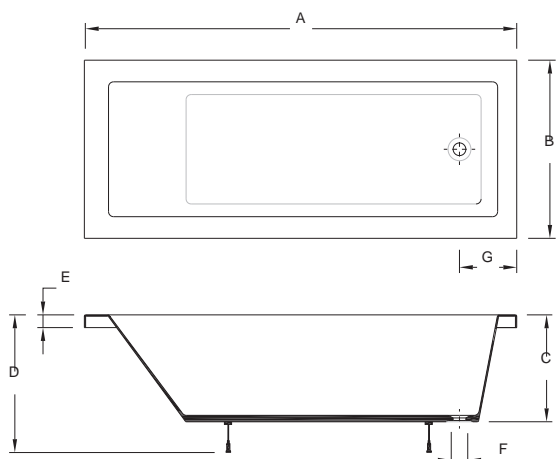

COTAS COAT COTTE COTAS	TOLERÂNCIAS MARGIN TOLERANCE TOLERANCIAS
> 1000	+5 -10
< 1000	+5 -5
EN 198	

DIMENSÕES DIMENSIONS DIMENSIONS						
Mod	1600x700	1700x700	1600x750	1700x750	1700x800	1800x800
A	1600	1700	1600	1700	1700	1800
B	700	700	750	750	700	800
C	400	400	400	400	400	400
D	MAX 725 / MIN 550	MAX 725 / MIN 550	MAX 725 / MIN 550	MAX 725 / MIN 550	MAX 725 / MIN 550	MAX 725 / MIN 550
E	50	50	50	50	50	50
F	Ø51	Ø51	Ø51	Ø51	Ø51	Ø51
G	230	230	230	250	230	230

Lagoa

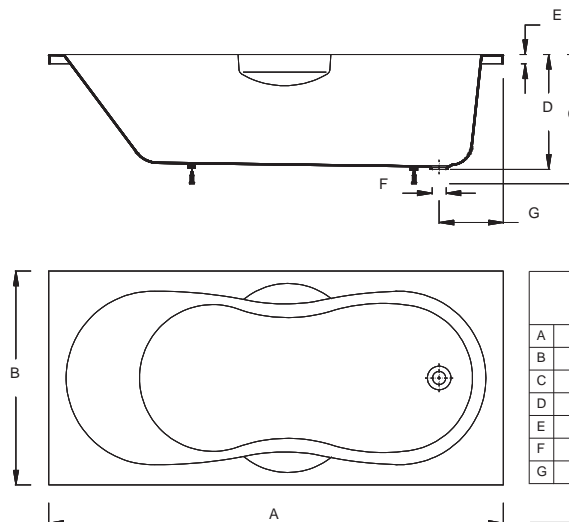

DIMENSÕES DIMENSIONS DIMENSIONS	
A	1700
B	800
C	MAX 670 / MIN 570
D	420
E	35
F	Ø52
G	265

COTAS COAT COTTE COTAS	TOLERÂNCIAS MARGIN TOLERANCE TOLERANCIAS
> 1000	+5 -10
< 1000	+5 -5
EN 198	

DESENHOS TÉCNICOS | TECHNICAL DRAWING | DESSINS TECHNIQUES

BANHEIRAS ACRILICAS | BATHTUBS ACRYLICS | BAINOIRES ACRYLIQUES pag.88 / 89

Gallery

Foz

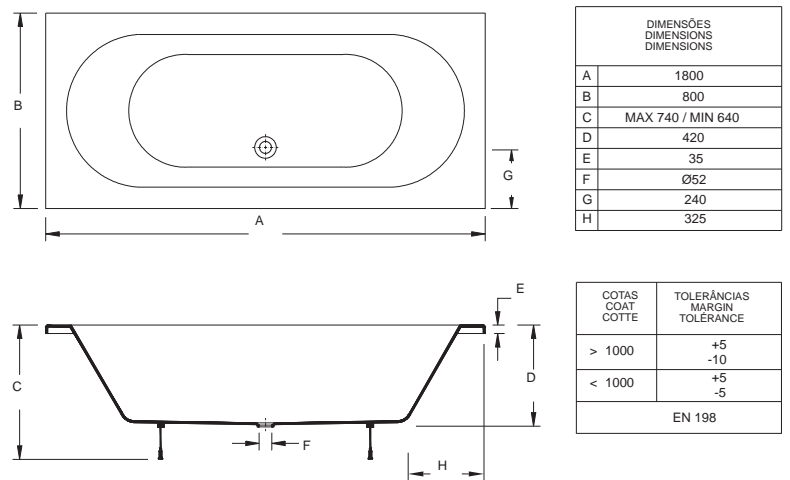
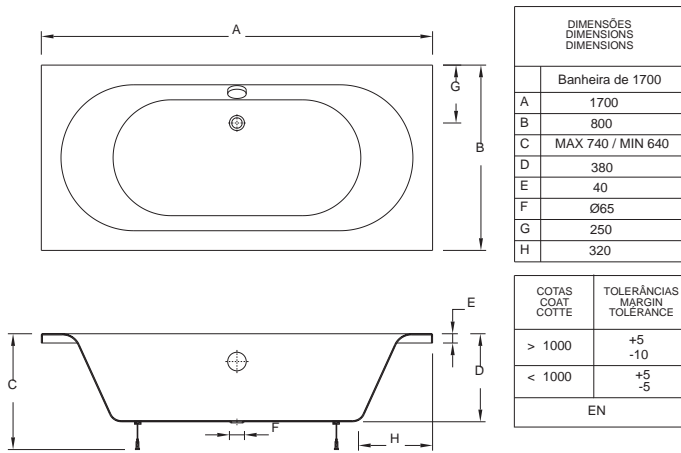

BANHEIRAS ACRILICAS | BATHTUBS ACRYLICS | BAINOIRES ACRYLIQUES pag.90

Atlantic

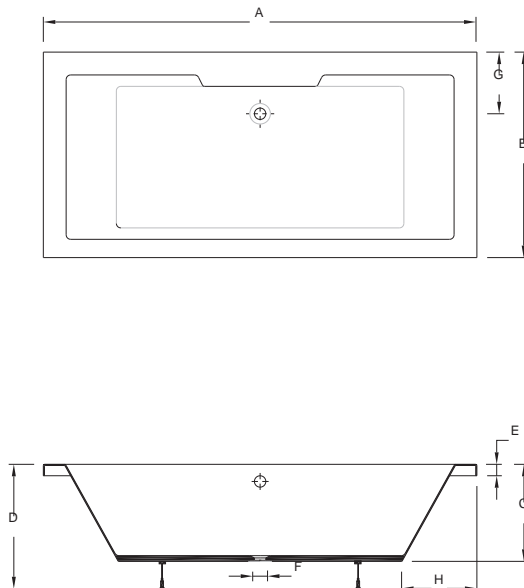

DIMENSÕES DIMENSIONS DIMENSIONS		
A	1900	2000
B	900	1000
C	400	400
D	MAX 725 / MIN 550	MAX 725 / MIN 550
E	50	50
F	Ø51	Ø51
G	250	250
H	330	330

COTAS COAT CÔTTE	TOLERÂNCIAS MARGIN TOLERANCE
> 1000	+5 -10
< 1000	+5 -5
EN 198	

DESENHOS TÉCNICOS | TECHNICAL DRAWING | DESSINS TECHNIQUES

BANHEIRAS CHAPA ESMALTADA | ENAMELLED STEEL BATHTUBS | BAIGNOIRES ACIER ÉMAILLE pag.92 / 93

Nueva Europa

América

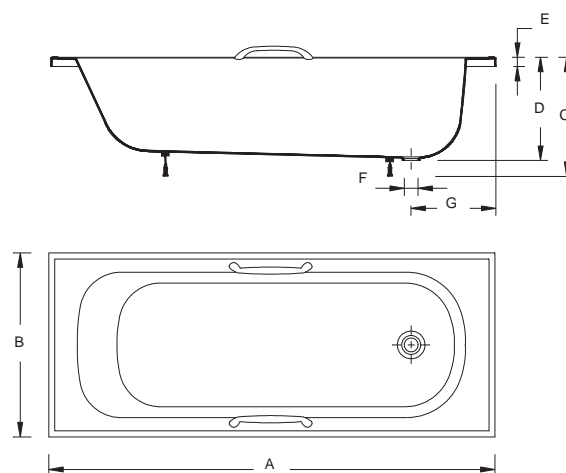
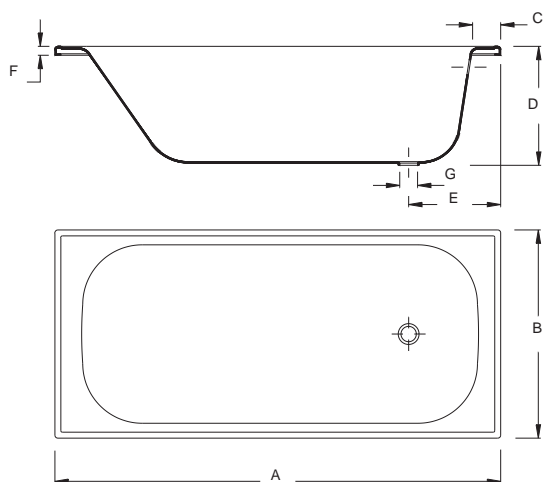

A	B	C	D	E	F	G
1700	700	105	372	300	30	Ø50
1600	700	105	372	300	30	Ø50
1500	700	105	375	300	30	Ø50
1400	700	105	372	300	30	Ø50
1300	700	70	372	275	30	Ø50
1200	700	70	372	275	30	Ø50
1000	700	70	372	275	30	Ø50

DIMENSÕES DIMENSIONS DIMENSIONS	
A	1700/1600/1500/1400
B	700
C	MAX 670 / MIN 570
D	372
E	28
F	Ø52
G	300

COTAS COAT COTTE	TOLERÂNCIAS MARGIN TOLERANCE
> 1000	+5 -10
< 1000	+5 -5
EN 198	

BANHEIRAS CHAPA ESMALTADA | ENAMELLED STEEL BATHTUBS | BAIGNOIRES ACIER ÉMAILLE pag.94

Dafne

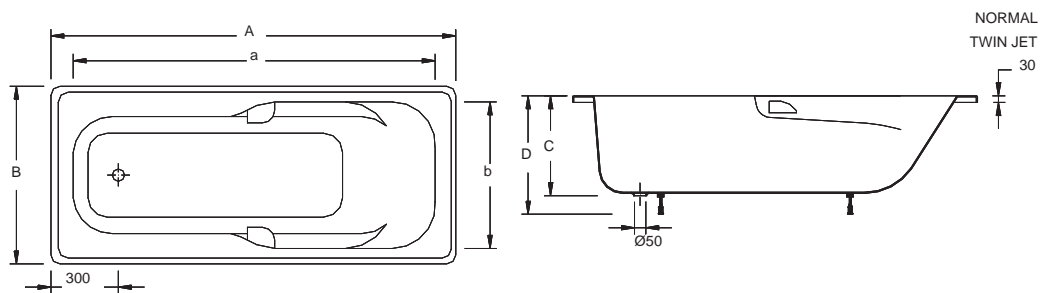

MODELO	A	B	a	b	C	D	D
1700x750	1700	750	1510	610	400	Normal Twin Jet Super Jet	500-555
1600x750	1600	750	1410	610	400	500-555	500-555

DESENHOS TÉCNICOS | TECHNICAL DRAWING | DESSINS TECHNIQUES

TORNEIRAS | FAUCETS | ROBINETTERIE DE SALLE DE BAIN pag.95

If

1. Monocomando lavatório
Basin Mixer
Mitigeur de lavabo

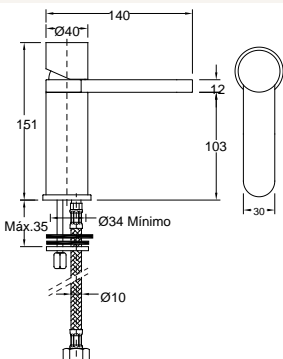

3. Monocomando de bidé
Bidet Mixer
Mitigeur de lavabo

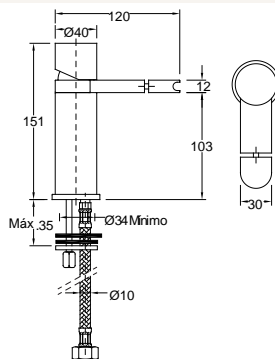

4. Misturadora de lavatório de parede
Wall mounted mixer
Mitigeur lavabo d'encastrer

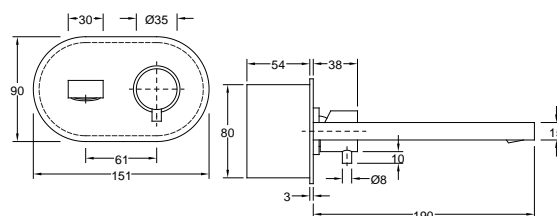

5. Monocomando banheira
Bathtub mixer
Mitigeur de baignoire

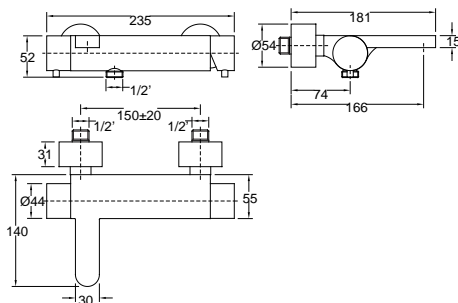

6. Monocomando de base de chuveiro
Wall mounted shower mixer
Mitigeur de douche sur d'encastrer

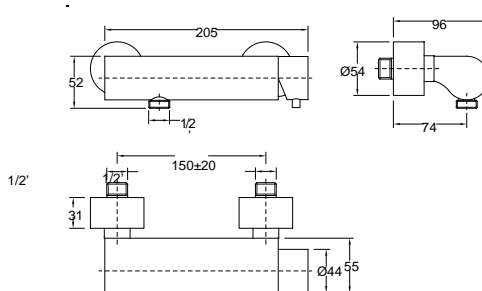

7. Misturadora de banheira de encastrar
Wall mounted shower mixer
Mitigeur de baignoire d'encastrer

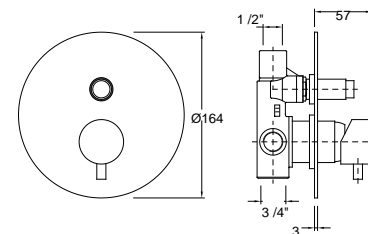

8. Misturadora de base de chuveiro de encastrar
Thermostatic wall mounted shower mixer
Mitigeur thermostatique de douche d'encastrer

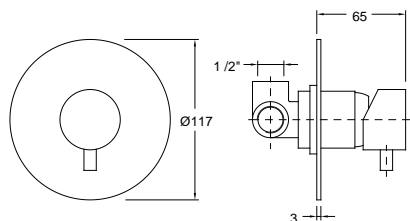

DESENHOS TÉCNICOS | TECHNICAL DRAWING | DESSINS TECHNIQUES

TORNEIRAS | FAUCETS | ROBINETTERIE DE SALLE DE BAIN pag.96

Lusiada

1. Monocomando lavatório / bidé válvula clic clac
Basin / Bidet Mixer
Mitigeur de lavabo

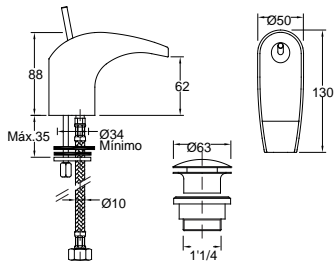

2. Extensor de lavatório alto
Extension for basin mixer
Extension pour mitigeur de lavabo

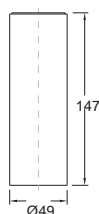

3. Monocomando lavatório de parede
Wall mounted basin
Mitigeur de lavabo d'encastrer

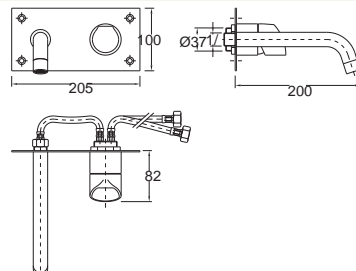

4. Monocomando banheira
Bathub mixer
Mitigeur de baignoire

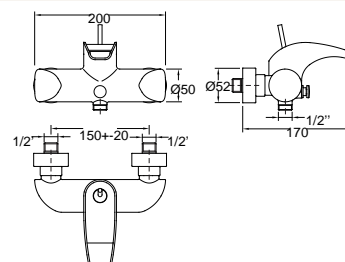

5. Monocomando base de chuveiro
Shower mixer
Mitigeur de douche

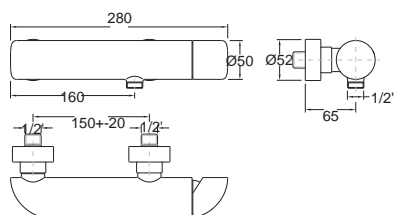

6. Monocomando de banca com bica rotativa
Sink mixer with swivel spout
Mitigeur de cuisine avec bec orientable

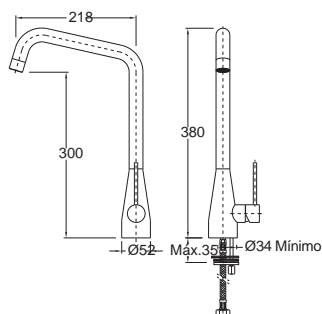

7. Monocomando de banca com bica rotativa e retráctil
Sink mixer with swivel spout and pull-out hand shower
Mitigeur de cuisine avec bec orientable et douchette extractible

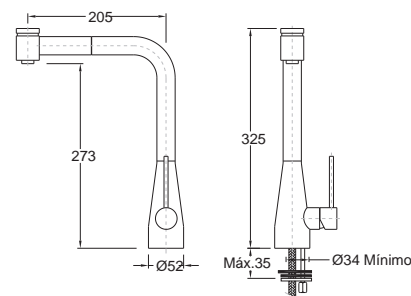

8. Misturadora de base de chuveiro de encastrar termostática
Thermostatic wall mounted shower mixer
Mitigeur thermostatique de douche d'encastrer

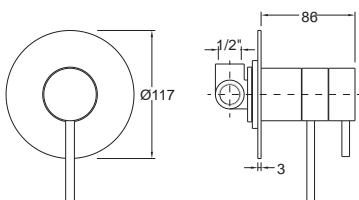

9. Misturadora de base de chuveiro de encastrar
Wall mounted shower mixer
Mitigeur de douche sur d'encastrer

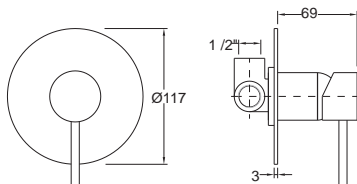

10. Misturadora de banheira de encastrar termostática
Thermostatic wall mounted shower mixer
Mitigeur thermostatique de baignoire d'encastrer

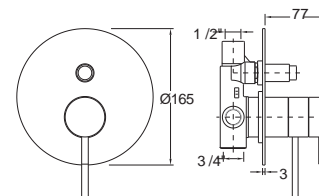

11. Misturadora de banheira de encastrar
Wall mounted bathtub mixer
Mitigeur de baignoire d'encastrer

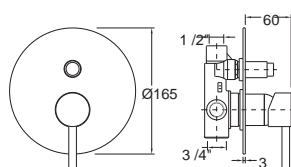

12. Misturadora de encastrar termostática c/ distribuidor 3 vias
Thermostatic wall mounted mixer with 3 ways
Mitigeur de baignoire / douche thermostatique d'encastrer

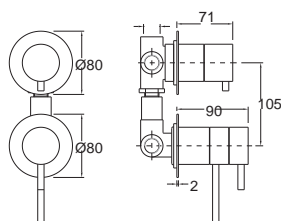

13. Misturadora de encastrar com distribuidor 3 vias
Wall mounted mixer with 3 ways
Mitigeur de baignoire / douche d'encastrer 3 sorties

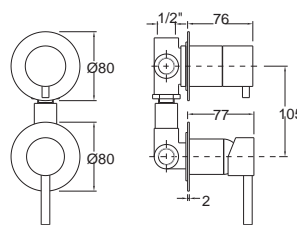

14. Bica de banheira de encastrar
Inlay water outlet for bathtub
Point eau pour baignoire

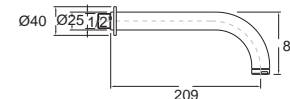

DESENHOS TÉCNICOS | TECHNICAL DRAWING | DESSINS TECHNIQUES

TORNEIRAS | FAUCETS | ROBINETTERIE DE SALLE DE BAIN pag.97

Cayenne

1. Monocomando lavatório válvula clic clac
Basin Mixer
Mitigeur de lavabo

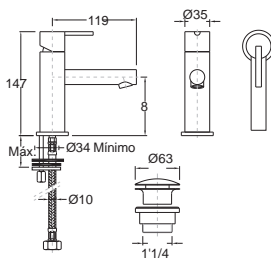

2. Extensor de lavatório alto
Extension for basin mixer
Extension pour mitigeur de lavabo

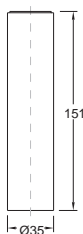

3. Monocomando lavatório de parede
Wall mounted basin
Mitigeur de lavabo d'encastrer

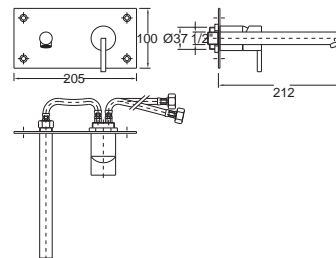

4. Monocomando bidé
Bidet mixer
Mitigeur de bidet

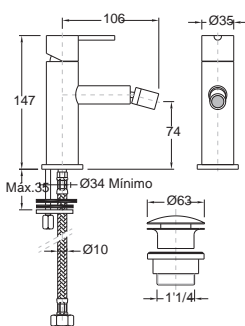

5. Monocomando banheira
Bathub mixer
Mitigeur de baignoire

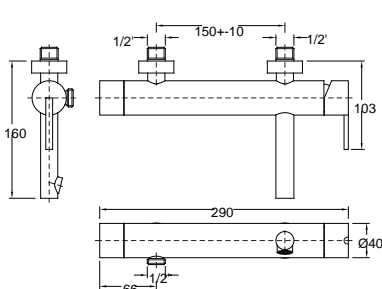

6. Monocomando base de chuveiro
Shower mixer
Mitigeur de douche

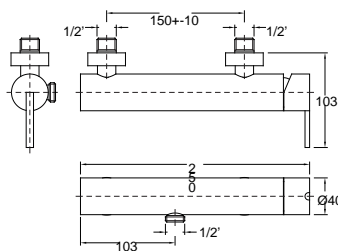

7. Monocomando de banca com bica rotativa
Sink mixer with swivel spout
Mitigeur de cuisine avec bec orientable

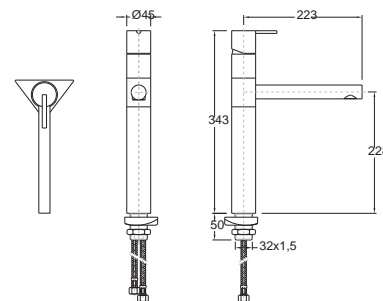

8. Misturadora de base de chuveiro de encastrar termostática
Thermostatic wall mounted shower mixer
Mitigeur de douchette thermostatique d'encastrer

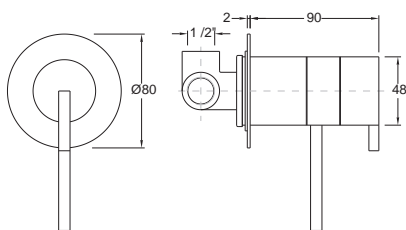

9. Misturadora de base de chuveiro de encastrar
Wallmounted shower mixer
Mitigeur de douchette thermostatique

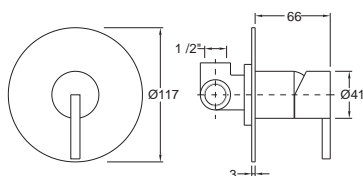

10. Misturadora de banheira de encastrar termostática
Thermostatic wall mounted shower/ bath mixer
Mitigeur de douchette thermostatique d'encastrer

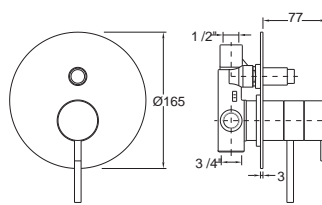

11. Misturadora de banheira de encastrar
Wall mounted shower/ bath mixer
Mitigeur de baignoire d'encastrer

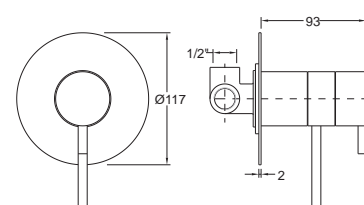

12. Misturadora de encastrar termostática c/ distribuidor 3 vias
Thermostatic wall mounted bathtub mixer with 3 ways
Mitigeur de baignoire / douche thermostatique d'encastrer

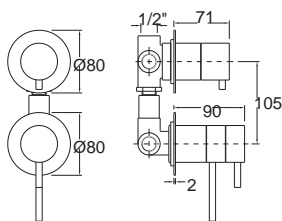

13. Misturadora de encastrar com distribuidor 3 vias
Wall mounted bathtub mixer with 3 ways
Mitigeur de baignoire/douche d'encastrer 3 sorties

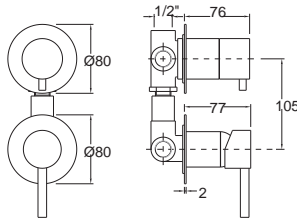

14. Bica de banheira de encastrar
Inlay water outlet for baignoire
Point eau pour douchette

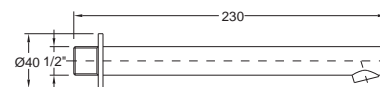

DESENHOS TÉCNICOS | TECHNICAL DRAWING | DESSINS TECHNIQUES

TORNEIRAS | FAUCETS | ROBINETTERIE DE SALLE DE BAIN pag.98

Fidji

1. Monocomando de lavatório
Basin mixer
Mitigeur de Lavabo avec vidage

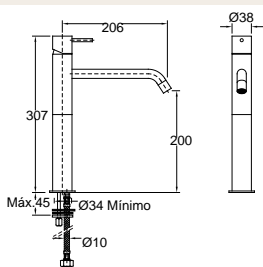

2. Monocomando de lavatório alto
Basin mixer for high level washbasin
Mitigeur de lavabo allongé avec vidage

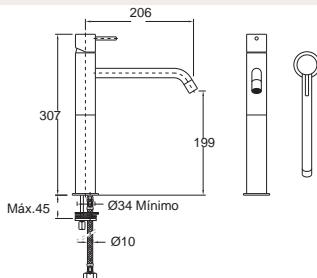

3. Monocomando de lavatório médio
Basin mixer
Mitigeur de Lavabo moyen avec vidage

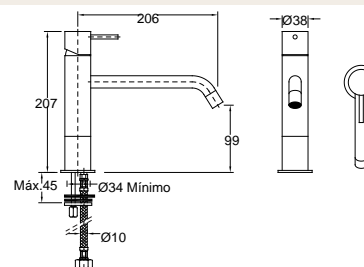

4. Monocomando lavatório de parede
Wall mounted basin
Mitigeur de lavabo d'encastrer

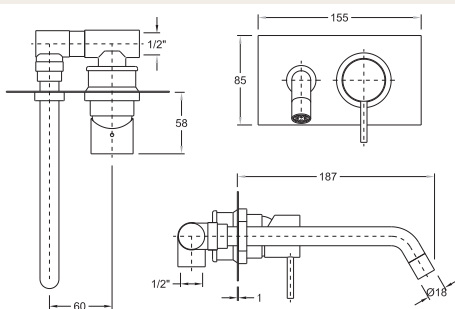

5. Monocomando de bidé
Bider mixer
Mitigeur de Bidet avec vidage

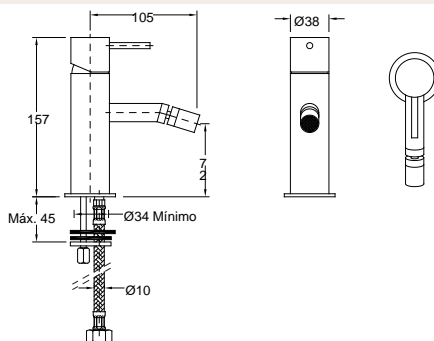

6. Monocomando de banheira
Bathtub mixer
Mitigeur Bain/Douche avec douchette

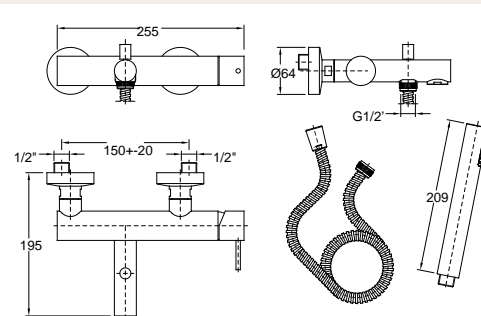

7. Monocomando de base de chuveiro
Shower mixer
Mitigeur douche avec douchette

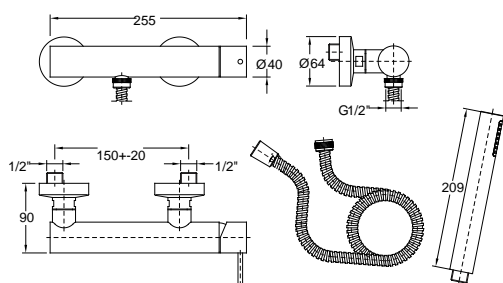

8. Rampa chuveiro | Shower rail | Barre de Douche

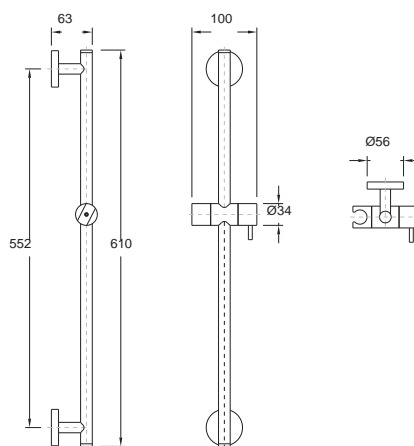

9. Misturadora de banca | Kitchen mixer
Mitigeur de cuisine

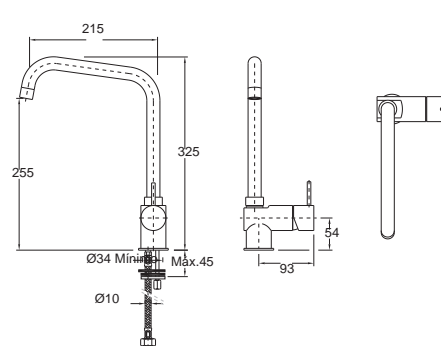

10. Misturadora de banheira de encastrar
Wall mounted shower/ bath mixer
Mitigeur de baignoire d'encastrer

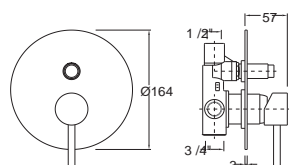

11. Misturadora de base de chuveiro de encastrar
Wall mounted shower mixer
Mitigeur de douchette thermostatique

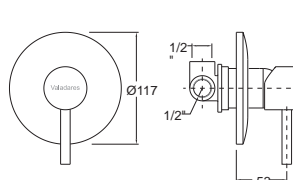

DESENHOS TÉCNICOS | TECHNICAL DRAWING | DESSINS TECHNIQUES

TORNEIRAS | FAUCETS | ROBINETTERIE DE SALLE DE BAIN pag.99

Assi (eco)

1. Monocomando de lavatório
Basin mixer
Mitigeur de Lavabo avec vidage

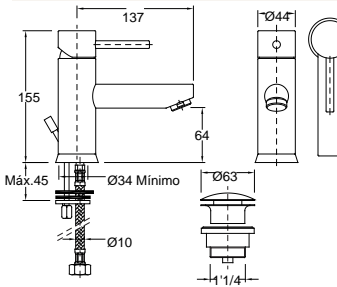

2. Monocomando de lavatório médio
Basin mixer
Mitigeur de Lavabo moyen avec vidage

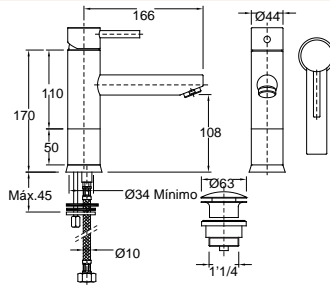

3. Monocomando de lavatório alto
Basin mixer for high level washbasin
Mitigeur de lavabo allongé avec vidage

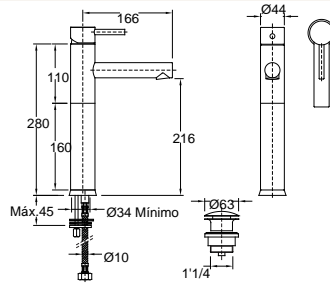

4. Monocomando de bidé com válvula click-clack
Bider mixer
Mitigeur de Bidet

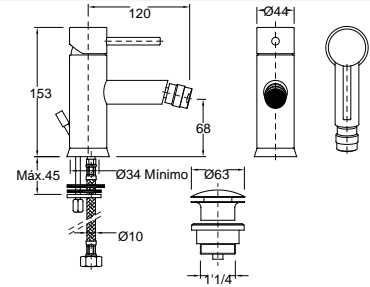

5. Monocomando de banheira
Bathub mixer
Mitigeur Bain/Douche avec douchette

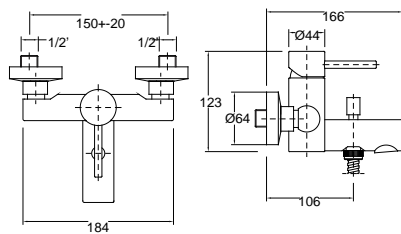

6. Monocomando de base de chuveiro
Shower mixer
Mitigeur douche avec douchette

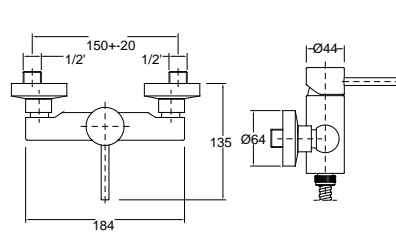

7. Misturadora de banca c/ bica giratória | Kitchen mixer
Mitigeur de cuisine avec bec orientable

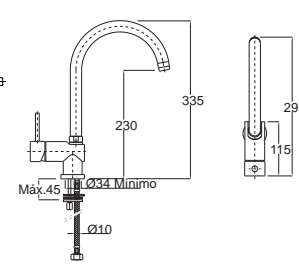

8. Misturadora de banca profissional
Kitchen mixer
Mitigeur de cuisine

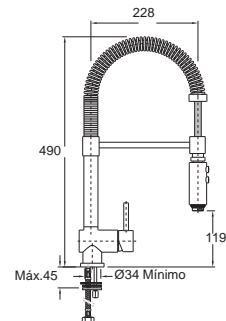

9. Misturadora de lavatório de parede
Washbasin wall mixer
Mélangeur 3 trous

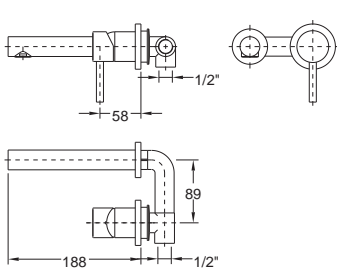

10. Passador 1/2
1/2" Tap
Robinette a encastrar 1/2

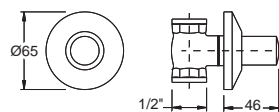

12. Misturadora base de chuveiro encastrar
Shower mixer inlay
Misturadora base de chuveiro encastrar

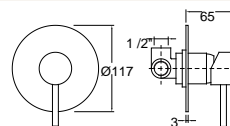

14. Chuveiro c/haste | Arm and Rose | Douchette encastré Assi

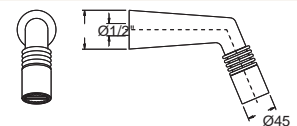

11. Passador 3/4
3/4" Tap
Robinette a encastrar 3/4

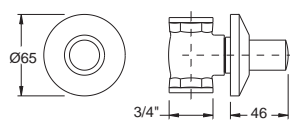

13. Misturador banheira encastrar
Bathub inlay
Mitigeur Douche encastré

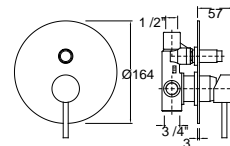

15. Bica banheira | Bathtub water outlet | Bec baignoire

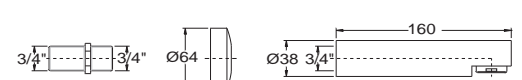

16. Torneira esquadria | 3/8" Tap
Robinet d'équerre 1/2 x 3/8 Assi

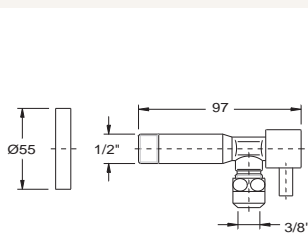

17. Rampa chuveiro | Shower rail
Barre de Douche

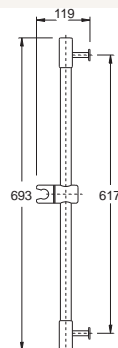

21. Tomada de água p/ chuveiro manual
Inlay mixer for shower tray
Robiner pour douche

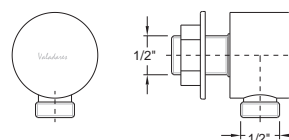

26. Torneira de lavatório de coluna
Pilar tap washbasin
Mitigeur lavabo colonne

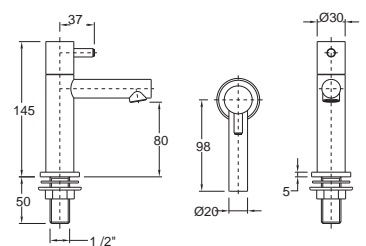

DESENHOS TÉCNICOS | TECHNICAL DRAWING | DESSINS TECHNIQUES

TORNEIRAS | FAUCETS | ROBINETTERIE DE SALLE DE BAIN pag.100

Lotto

1. Misturadora de lavatório
Basin mixer
Mitigeur de Lavabo avec vidage

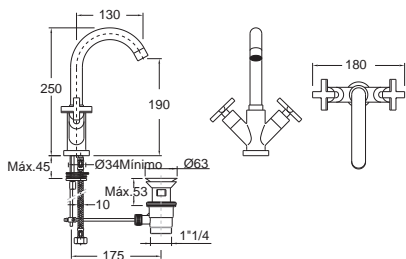

2. Misturadora de parede
Wall mounted tap
Mitigeur de mur

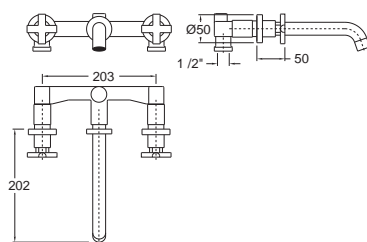

3. Misturadora de bidé
Bider mixer
Mitigeur de Bidet avec vidage

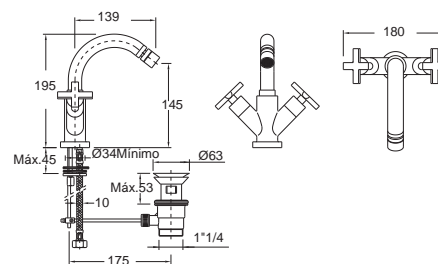

4. Misturadora de banheira
Bathub mixer
Mitigeur Bain/Douche avec douchette

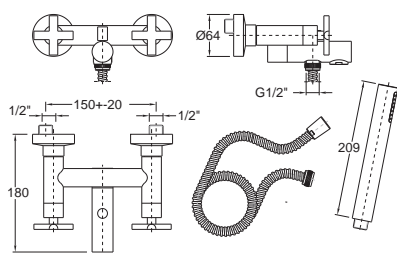

5. Misturadora de base de chuveiro
Shower mixer
Mitigeur douche avec douchette

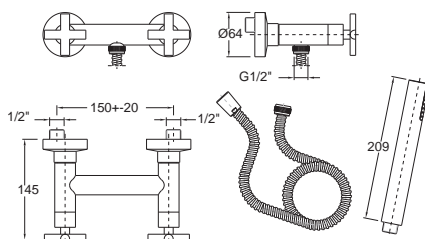

6. Misturadora de banca / bica giratória | Kitchen mixer
Mitigeur de cuisine avec bec orientable

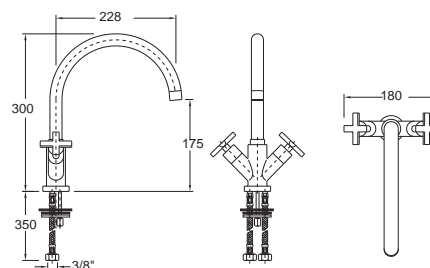

7. Rampa chuveiro | Shower rail | Barre de Douche

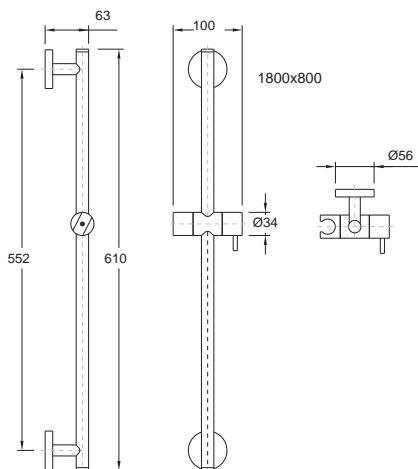

10. Misturadora de banheira de encastrar
Bathub inlay
Mitigeur Douche encastré

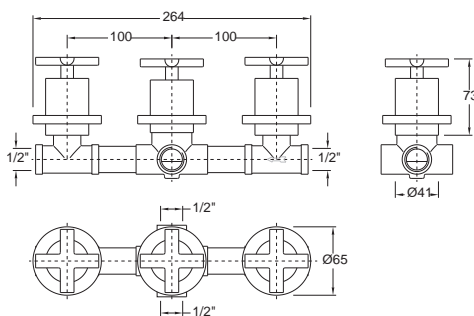

DESENHOS TÉCNICOS | TECHNICAL DRAWING | DESSINS TECHNIQUES

TORNEIRAS | FAUCETS | ROBINETTERIE DE SALLE DE BAIN pag.101

Alicante

1. Monocomando de lavatório
Single lever for washbasin with pop up
Mitigeur lavabo avec vidage

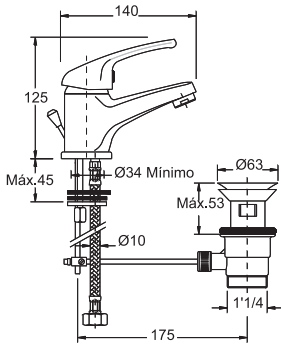

2. Monocomando de base de chuveiro
Wall mounted tap for shower tray
Mitigeur de douche

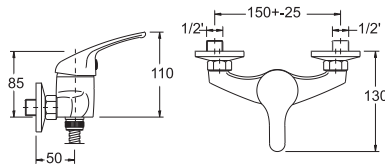

3. Monocomando de banheira
Single lever for bathtub
Mitigeur de bain/douche

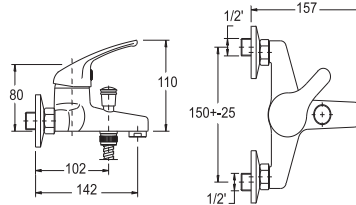

Passador 1/2" | Tap 1/2" | Passador 1/2"

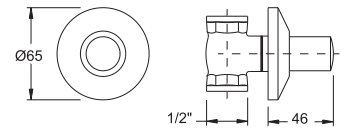

Passador 3/4" | Tap 3/4" | Passador 3/4"

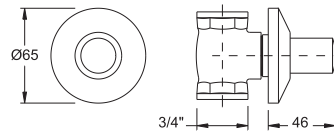

4. Monocomando de bidé
Single lever for bidet with pop up
Mitigeur de bidet avec vidage

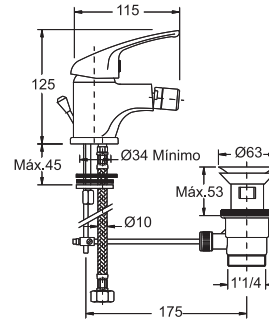

5. Monocomando de banca rotativa
Kitchen mixer
Mitigeur cuisine avec bec orientable

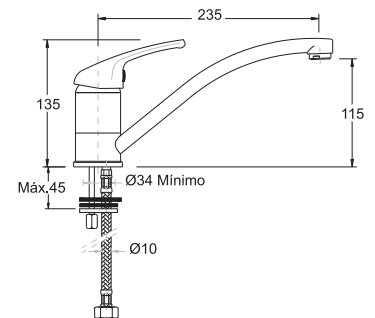

TORNEIRAS | FAUCETS | ROBINETTERIE DE SALLE DE BAIN pag.101

Valência

1. Monocomando de lavatório
Single lever for washbasin with pop up
Mitigeur lavabo avec vidage

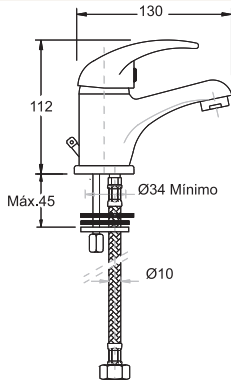

2. Monocomando de bidé
Single lever for bidet with pop up
Mitigeur de bidet avec vidage

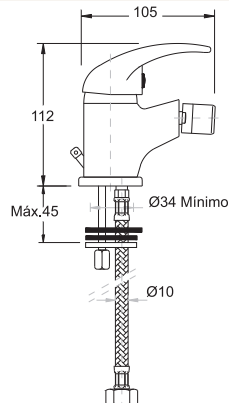

3. Monocomando de banheira
Single lever for bathtub
Mitigeur de bain/douche

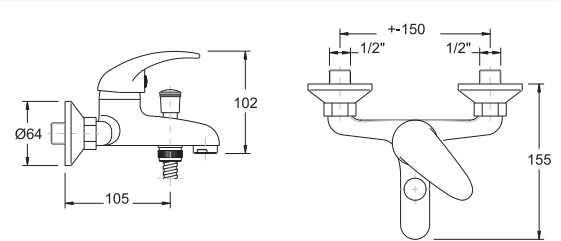

4. Monocomando de base de chuveiro
Wall mounted tap for shower tray
Mitigeur de douche

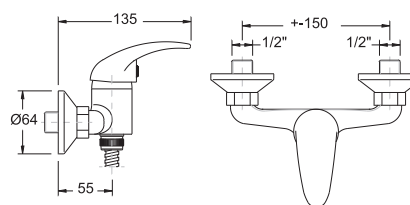

5. Monocomando de banca rotativa
Kitchen mixer
Mitigeur cuisine avec bec orientable

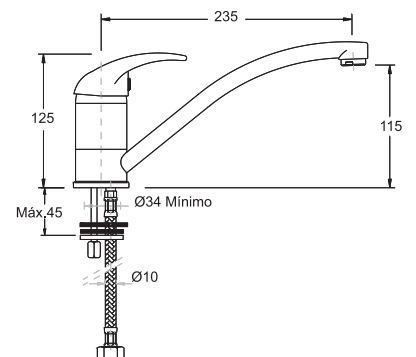

DESENHOS TÉCNICOS | TECHNICAL DRAWING | DESSINS TECHNIQUES

TORNEIRAS TEMPORIZADAS | TIMER TAP | TIMER ROBINET pag.102 / 103

Dream

Torneira Temporizada para lavatório Assi | Timer tap Assi for washbasin
Timer mitigeur Assi pour lavabo

Torneira Temporizada Assi para urinol | Timer tap Assi for urinal
Timer mitigeur Assi pour urinoir

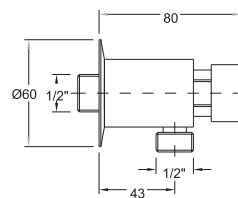
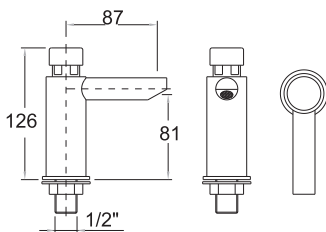
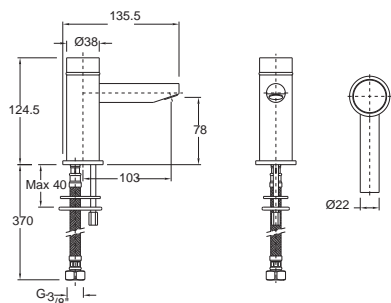

Torneira temporizada Assi p/ chuveiro de encastrar
Timer tap Assi for wall mounted shower tray
Timer mitigeur Assi pour douche d'encastrement

Torneira temporizada de lavatório Assi |
Timer tap Assi for washbasin |
Timer mitigeur Assi pour lavabo

Chuveiro temporizado Spacio |
Timer arm and rose Spacio |
Timer douche Spacio

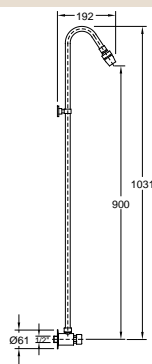
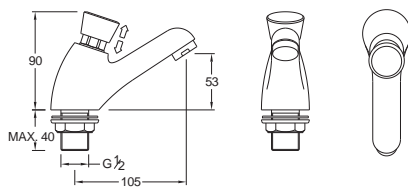
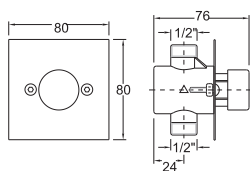

TORNEIRAS TEMPORIZADAS FLUXO | TIMER TAP FLUXO | TIMER ROBINET FLUXO pag.104

Torneira temporizada de lavatório FLUXO | Timer tap Fluxo for washbasin |
Timer mitigeur Fluxo pour lavabo

Fluxómetro exterior para sanita c/ regulação de caudal FLUXO | Outside flowmeter
for wc with flow adjustment | Fluxomètre pour wc avec ajustement de flux

Fluxómetro de embutir para sanita FLUXO | Inlay flowmeter
for wc | Fluxomètre embed pour wc

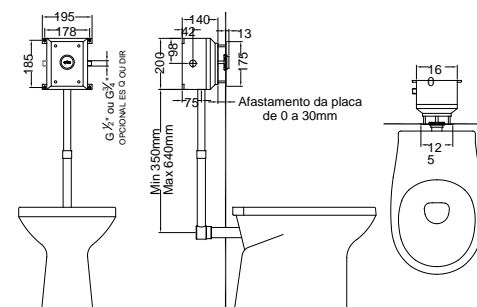
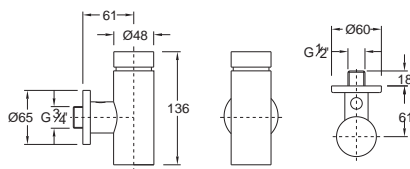
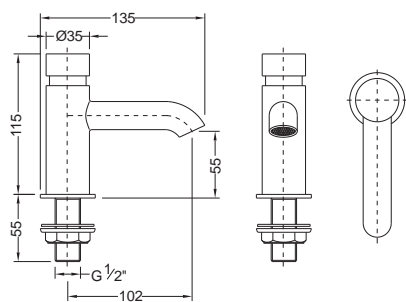

Fluxómetro exterior para urinol c/ regulação de caudal FLUXO
Outside flowmeter for urinal with flow adjustment |
Fluxomètre extérieur pour urinoir avec ajustement de flux

Fluxómetro de embutir para urinol FLUXO (cromado) |
Inlay flowmeter for urinal |
Fluxomètre embed pour urinoir

Kit instalação fluxómetro exterior sanita

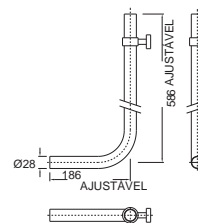
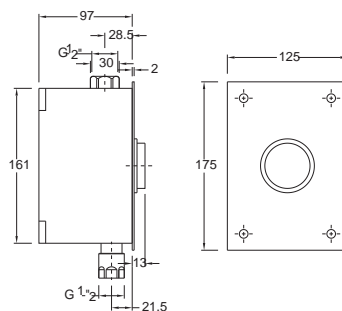
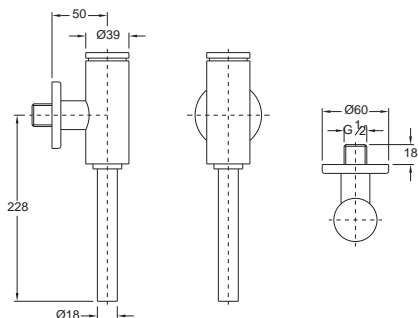

DESENHOS TÉCNICOS | TECHNICAL DRAWING | DESSINS TECHNIQUES

COLUNAS | COLUMNS | COLONNES | COLUMNAS pag.105 / 106

Coluna cerâmica de hidromassagem com misturadora termostática Tissus |
Ceramic wall mounted thermostatic whirlpool column Tissus |
Colonne ceramique Tissus avec hidromassage

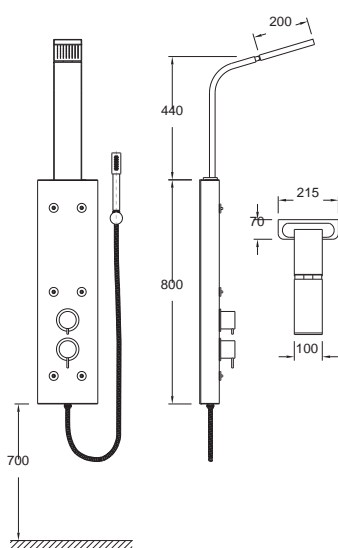

Chuveiro Dib | Arm and rose Dib | Douche Dib
Misturadora de encastrar chuveiro
Misturadora de encastrar banheira

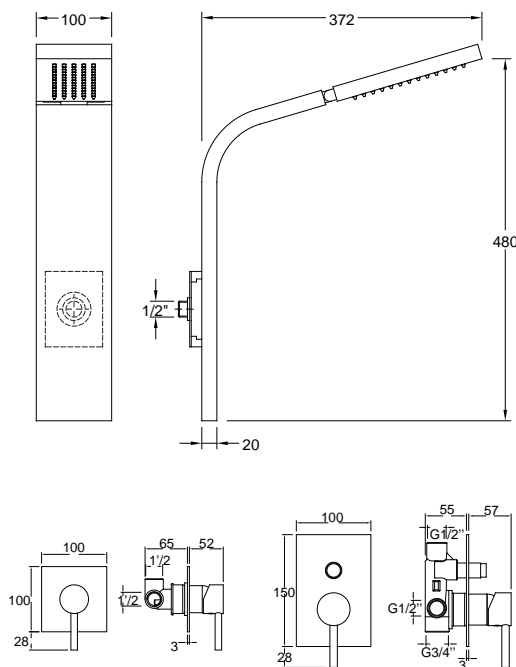

Coluna de hidromassagem Termoestática de parede Michigan |
Wall mounted thermostatic whirlpool column Michigan |
Colonne hidromassage thermostatique Michigan

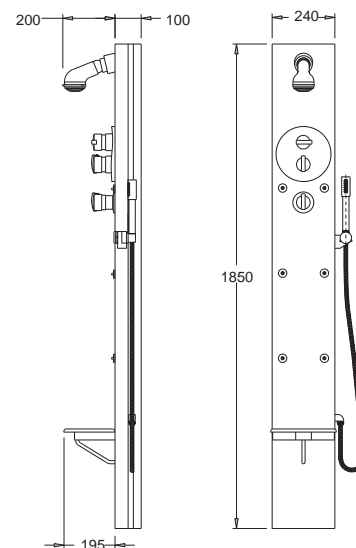

COLUNAS | COLUMNS | COLONNES pag.106 / 108

Coluna de hidromassagem Monocomando de parede Michigan |
Wall mounted monobloc whirlpool column Michigan |
Colonne hidromassage avec mélangeur Michigan

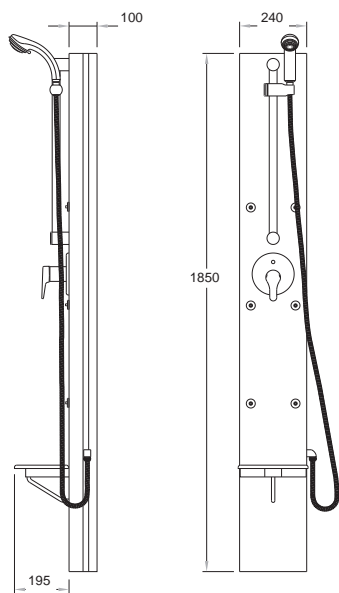

Coluna de hidromassagem Termoestática de parede Sri Lanka |
Wall mounted thermostatic whirlpool column Sri Lanka
Colonne thermostatique Sri Lanka

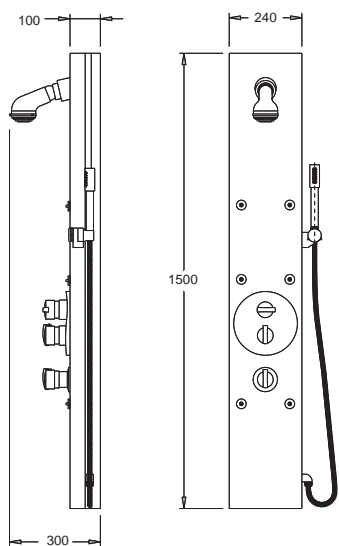

Coluna de hidromassagem Monocomando de parede Sri Lanka |
Wall mounted monobloc whirlpool column Sri Lanka |
Colonne hidromassage Sri Lanka

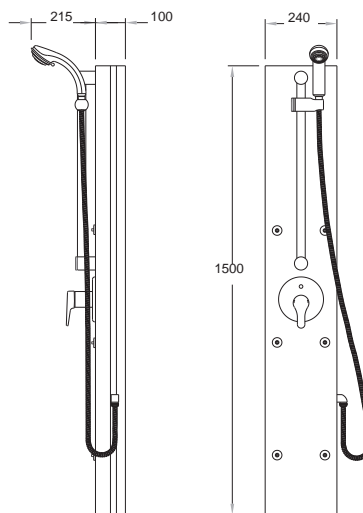

Coluna para base de chuveiro Comoros |
Wall mounted thermostatic whirlpool column Comoros |
Colonne pour bac a douche Comoros

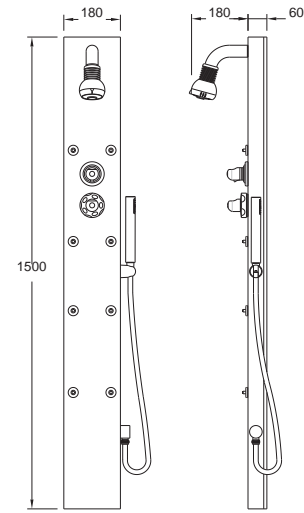

DESENHOS TÉCNICOS | TECHNICAL DRAWING | DESSINS TECHNIQUES

COLUNAS | COLUMNS | COLONNES pag.108 / 109

Coluna de hidromassagem para banheira Comoros |
Wall mounted thermostatic whirlpool column Comoros | Colonne hydromassage
pour baignoire Comoros

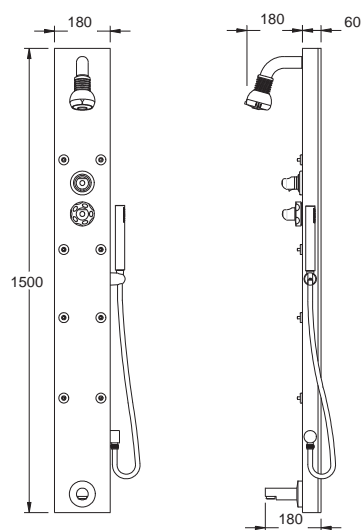

Misturadora de chuveiro c/ coluna de chuveiro Cairo |
Column shower mixer with arm and rose Cairo | Mitigeur de douche colonne
avec douche Cairo

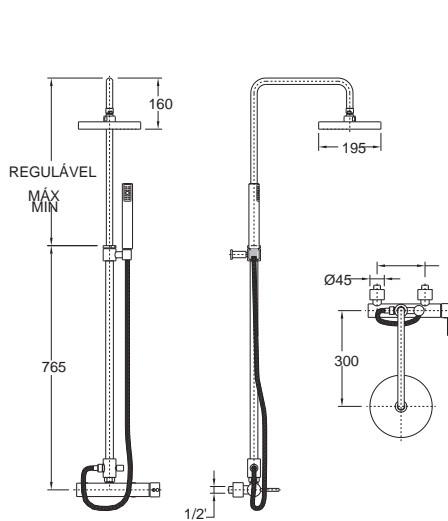

Misturadora de banheira c/ coluna de chuveiro Cairo |
Column shower mixer with arm and rose Cairo | Mitigeur de douche
colonne avec douche Cairo

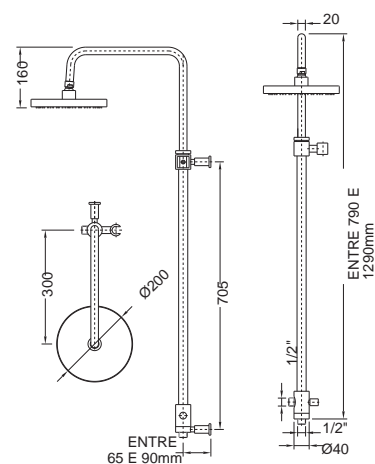

COLUNAS | COLUMNS | COLONNES pag.109 / 110

Misturadora de chuveiro c/ coluna de chuveiro Calcutá |
Column shower mixer with arm and rose Calcutá |
Mitigeur de douche colonne avec douche Calcutá

Misturadora de banheira c/ coluna de chuveiro Calcutá |
Column shower mixer with arm and rose Calcutá |
Mitigeur de douche colonne avec douche Calcutá

Haste de tecto Cairo e Calcutá (Ø10 cm, Ø20 cm,
Ø30 cm) | Stem wall | Mur souches

Chuveiro redondo Cairo (Ø 20 cm) pag.59
Arm and rose Cairo (Ø 20 cm)
Douche rond Cairo (Ø 20 cm)

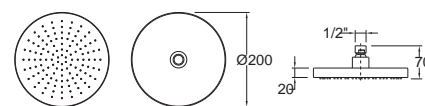
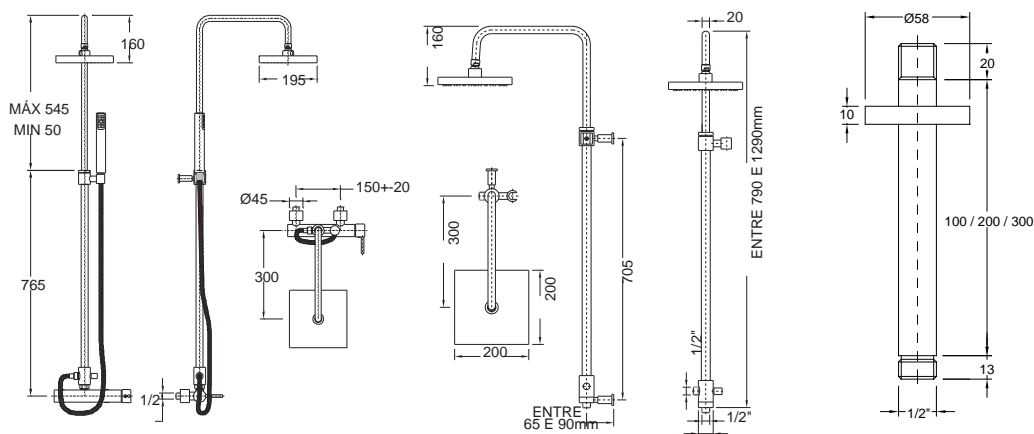

Chuveiro quadrado Calcutá (20 x 20cm) | pag.59
Arm and rose Calcutá (20 x 20cm)
Douche Carré Calcutá (20 x 20cm)

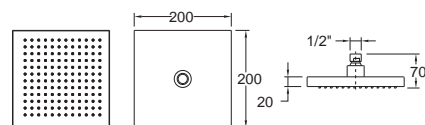

Gresanit®

Em 2006 a Valadares decidiu reunir esforços da sua equipa técnica para dar resposta a uma exigência do mercado:

Produzir peças cerâmicas de grande dimensão, mas sem as desvantagens de resistência e fiabilidade de produtos similares em Fine FireClay (Grés).

O desafio consistia em obter um material que conferisse boas características de resistência mecânica e ao fendilhamento e que assegurasse a tradicional qualidade dos artigos produzidos pela Cerâmica de Valadares em Porcelana sanitária.

Assim nasceu o Gresanit®, como resultado do trabalho de investigação e desenvolvimento do seu Departamento Técnico, abrindo portas ao fabrico e comercialização de um conjunto apreciável de artigos como Bases de Chuveiro de baixo perfil, Urinóis, Placas para aplicação de lavatórios e outras peças muito específicas. O Gresanit® permitiu alargar notavelmente a sua gama de produtos e oferecer soluções em Cerâmica que concorrem com vantagem com outros materiais alternativos.

A seguir, damos conta dos resultados de testes físicos, para a execução dos quais continuamos a contar com a empresa Ceram Research, da qual somos associados e participantes em diversos programas de investigação e desenvolvimento no domínio da cerâmica dos sanitários.

Gresanit®

In 2006 Valadares decided to bring together the best efforts of its technical team to reply to a market demand.

Producing ceramic pieces which are large but without the disadvantages of resistance and reliability of similar products of Fine FireClay (Sandstone).

And so Gresanit® came about, the upshot of R&D work by its technical department, opening up the way to the manufacture and commercialisation of a considerable set of items such as low profile Shower Bases, Urinals. Plates for the application of washbasins and other very specific pieces. Gresanit® allowed the notable expansion of its range of products and offer Ceramics solutions which have a competitive edge over other alternative materials.

Below we have set out the results of physical tests for the implementation whereof we will still rely on Ceram Research with whom we are associated, participating in various R&D programmes in the field of sanitary ceramics.

Gresanit®

En 2006, Valadares a décidé de déployer des efforts au sein de son équipe technique afin de répondre à une exigence du marché :

Produire des pièces en céramique de grande dimension mas sans les inconvénients des produits similaires en Fine Fire Clay (grès) en matière de résistance et de fiabilité.

Le défi consistait à obtenir un matériau présentant de bonnes caractéristiques de résistance mécanique et au tressailage, pouvant également assurer la qualité traditionnelle des articles en porcelaine sanitaire produits par Cerâmica de Valadares.

C'est ainsi qu'est apparu Grenasit®, suite à un travail de recherche et développement entrepris par le Département Technique. Par la suite, nous avons débuté la fabrication et la commercialisation d'un ensemble d'articles considérable : bases de douche à bas profil, urinoirs, plaques destinées à la pose de lavabos et autres pièces très spécifiques. Grenasit® a ainsi pu élargir remarquablement sa gamme de produits et proposer des solutions en céramique qui représentent plusieurs avantages face à d'autres matériaux alternatifs.

Ensuite, nous présentons les résultats des tests physiques dont l'exécution est assurée par la société Ceram Research dont nous sommes associés. Nous participons également à plusieurs programmes de recherche et développement dans le domaine de la céramique sanitaire.

* Résultat des tests au GRESANIT® et Vitreous China Valadares

*Resultado dos testes ao GRESANIT® e ao Vitreous China Valadares

*Test Results on GRESANIT® and Vitreous China Valadares | *Resultats des testes au GRESANIT® et Vitreous China de Valadares

	Abs. Água Water Abs. Porosité (%) (EN 997)	Res. Mecânica M.O.R Résistance mécanique (Kgf/cm ²) (PT14)	Fendilhagem Crazing Tressailage (autoclave) (BS3402;B)	Res. ao ataque químico Chemical attack resistance Résistance à l'attaque chimique (BS2402;C)	Resistência ao impacto Impact Resistance Résistance à l'impact (kgf/cm) (ASTMC368-88)
Vitreous	0,04	710	Passou Pass Approuvé Superada	Passou Pass Approuvé Superada	5.8
GRESANIT®	4.50	510	Passou Pass Approuvé Superada	Passou Pass Approuvé Superada	8.2

*Testes realizados pela FCV durante o período de Janeiro a Julho de 2010 com amostras da produção em curso. Devem ser considerados como valores médios.

(*) Tests carried out by FCV during the period January to July 2010 with production samples in progress

(*) Tests réalisés par FCV entre janvier et juillet 2010 à partir d'échantillons de la production en cours. Ces résultats doivent être considérés comme des valeurs moyennes.



THE INTERNATIONAL CERTIFICATION NETWORK

CERTIFICATE

iQNet and
APCER

hereby certify that the organization
FÁBRICA CERÂMICA DE VALADARES, S.A.

Rua Dr. Manuel Moreira da Costa Jr,
4406-951 VILA NOVA DE GAIA - PORTUGAL

for the following field of activities

Manufacturing and trading of sanitary ware and accessory;
manufacturing (establish and test), trading and technical assistance of
hydrobaths; trading of complementary bathrooms products

has implemented and maintains a

Environmental Management System

Which fulfils the requirements of the following standard

ISO 14001:2004

Issued on: 2010-10-26

Validity date: 2013-10-25

Registration Number: PT- 2001/AMB.036



Michael Drechsel
President of IQNet

José Leitão
APCER CEO



Any additional statements concerning the scope of this certificate may be obtained by consulting APCER.

iQNet Partners*

AENOR Spain AFNOR Certification France ANV-Vlaanderen International Belgium ANCS Mexico APCER Portugal CCC China
CISQ Italy CQC China CQM China CQS Czech Republic Cst Cert Croatia DQS Germany DS Denmark ELOT Greece FCV Brazil
FONDKONORMA Venezuela IQQA Hong Kong China ICQTEC Colombia IMC Mexico Inspira Certification Finland IRAM Argentina JQA Japan KQS Korea NIST Hong Kong NENCO AS Norway NTA Ireland
PCBC Ireland Quality Assista Assuta BR Russia SII Israel SIIQ Slovenia SIRM QAS International Malaysia SGS Switzerland
SQAAC Romania TEST DE Petroburg Russia TRS Turkey TÜQS Serbia

iQNet is represented in the USA by APCER Certification, CISO, DQS Holdings GmbH and NSAI Inc.

*The list of iQNet partners is valid at the time of issue of this certificate. Updated information is available under www.iqnet-certification.com



Certificado de Conformidade Certificate of Registration

NÚMERO 2001/AMB.036
Number

APCER - Associação Portuguesa de Certificação certifica que o Sistema de Gestão Ambiental da
APCER - Associação Portuguesa de Certificação certifies that the quality system of

FÁBRICA CERÂMICA DE VALADARES, S.A.

Rua Dr. Manuel Moreira da Costa Jr.
4406-951 VILA NOVA DE GAIA
PORTUGAL

implementado na produção e comercialização de louça sanitária e acessórios; produção (montagem e teste), comercialização e assistência técnica e banheiras de hidromassagem; comercialização de produtos complementares para a casa de banho, cumpre os requisitos da norma
implemented in the manufacturing and trading of sanitary ware and accessory; manufacturing (establish and test), trading and technical assistance of hydrobaths; trading of complementary bathrooms products; meets the requirements of

NP EN ISO 14001:2004

Sistema de Gestão Ambiental - Requisitos e Linhas de Orientação para a sua utilização
Environmental Management System - Requirements and Guidelines for use

Data de emissão 2010-10-26
Date of issue

Válido até 2013-10-25
Valid until

José Leitão
José Leitão

Qualquer declaração adicional sobre este certificado pode obter-se consultando a APCER



APCER - Associação Portuguesa de Certificação
Edifício de Desenvolvimento, 2º andar, Av. Dr. António Almeida
4406-617 Lagoa de Paços
www.apcer.pt



THE INTERNATIONAL CERTIFICATION NETWORK

CERTIFICATE

iQNet and
APCER

hereby certify that the organization
FÁBRICA CERÂMICA DE VALADARES, S.A.

Rua Manuel Moreira da Costa Jr. EC Valadares
4406-951 Vila Nova de Gaia - PORTUGAL

with the related sites presented in the annex to this certificate
for the following field of activities

Manufacturing and trading of sanitary ware and accessory; manufacturing
(establish and test), trading and technical assistance of hydrobaths; trading
of complementary bathrooms products

has implemented and maintains a

Quality Management System

Which fulfils the requirements of the following standard

ISO 9001:2000

Issued on: 2008-10-31

Validity date: 2011-10-30

Registration Number: PT- 1999/CEP.907



René Wasmser
President of IQNet

José Leitão
APCER CEO



Any additional statements concerning the scope of this certificate may be obtained by consulting APCER.

iQNet Partners*

AENOR Spain AFNOR Certification France ANV-Vlaanderen International Belgium ANCS Mexico APCER Portugal CCC China
CISQ Italy CQC China CQM China CQS Czech Republic Cst Cert Croatia DQS Germany DS Denmark ELOT Greece FCV Brazil
FONDKONORMA Venezuela IQQA Hong Kong China ICQTEC Colombia IMC Mexico Inspira Certification Finland
IRAM Argentina JQA Japan KQS Korea NIST Hong Kong NENCO AS Norway NTA Ireland PCBC Ireland
Quality Assista Assuta BR Russia SII Israel SIIQ Slovenia SIRM QAS International Malaysia SGS Switzerland
SQAAC Romania TEST DE Petroburg Russia TRS Turkey TÜQS Serbia

iQNet is represented in the USA by APCER Certification, CISO, DQS, IRAM Inc. and NSAI Global

*The list of iQNet partners is valid at the time of issue of this certificate. Updated information is available under www.apcer-certification.com



Certificado de Conformidade Certificate of Registration

NÚMERO 1999/CEP.907
Number

A Associação Portuguesa de Certificação (APCER) certifica que o sistema de qualidade da
The Portuguese Association for Certification (APCER) certifies that the quality system of

FÁBRICA CERÂMICA DE VALADARES, S.A.

Rua Manuel Moreira da Costa Jr. EC Valadares
4406-951 Vila Nova de Gaia
PORTUGAL

com os locais apresentados em anexo a este certificado
with the related sites presented in the annex to this certificate

implementado na produção e comercialização de louça sanitária e acessórios; produção (montagem e teste), comercialização e assistência técnica e banheiras
implemented in the manufacturing and trading of sanitary ware and accessory; manufacturing (establish and test), trading and technical assistance of hydrobaths; trading of
complementary bathrooms products; meets the requirements of

NP EN ISO 9001:2000

Sistema de Gestão da Qualidade - Requisitos
Quality Management System Requirements

Data de emissão 2008-10-31
Date of issue

Válido até 2011-10-30
Valid until

José Leitão
José Leitão

Qualquer declaração adicional sobre este certificado pode obter-se consultando a APCER



Esta certificação é emitida por um organismo de certificação credenciado
This certification is issued by an accreditation body
www.apcer.pt





Valadares



VALADARES PORTUGAL
Fábrica Cerâmica de Valadares, S.A.
Apartado 3 / EC Valadares
4406 - 951 Vila Nova De Gaia
Tel: +351 227 150 000

Departamento Comercial
Tel: +351 227 150 046
Fax: +351 227 150 091
E-mail: comercial@valadares.com

Assistentes Comerciais
Norte/Porto: +351 227 150 036
Centro: +351 227 150 046
Lisboa: +351 227 150 037
Alentejo/Algarve/Madeira/Açores: +351 227 150 075

Delegação de Lisboa
Rua Padre Américo, 25-A
1600 - 864 Lisboa
Tel: +351 217 120 466
Fax: +351 217 120 468
valadareslisboa@valadares.com

Delegação do Algarve
Rua Cristovão Pires Norte
Edifício Brito, Lote 140 LojaB
8135-117 Almancil - Algarve
Tel: +351 289 315 790
Fax: +351 289 316 727
valadaresalgarve@valadares.com

Export Department
Tel: +351 227 150 042
Fax: +351 227 150 093
rogeriomesquita@valadares.com

Commercial Assistants
Tel: +351 227 150 022
+351 227 150 058
+351 227 150 076
+351 227 150 099
Fax: +351 227 150 093